

MV

PROFILE CATALOGUE



ALUMINIUM
EXTRUSIONS

MV EXTRUSIONS

#27,1st Cross,1st Main Byatarayanapura,Behind Satellite Bus Stand,Mysore Road Bangalore-560026
PH:9606518080/9606618080 Email: mvextrusions@gmail.com

INDEX

SR NO	TITLE	PAGE NO
	3/4 Series	
1	Single Track top	11
2	Single Track Bottom	11
3	2 Track Top	12
4	2 Track Bottom	12
5	3 Track Top	13
6	3 Track Bottom	13
7	4 Track Top	14
8	4 Track Bottom	14
9	5 Track Top	15
10	5 Track Bottom	15
11	¾ Handle	16
12	¾ Top Bottom	16
13	¾ Interlock	17
14	¾ Bearing Bottom	17
15	¾ Glass Meating	18
	1" Series	
16	2 Track Top	19
17	2 Track Bottom	19
18	3 Track Top	20
19	3 Track Bottom	20
20	1" Handle	21
21	1" Interlock	21
22	1" Glass Meating	22
23	1" Square Tube With 1 Lip	22
24	1" Square Tube with 2 Lip	23
	18 x 50 Section	
23	18 x 50 Handle	24
24	18 x 50 Interlock	24
	18 x 60 Section	
26	18 x 60 Handle	25
27	18 x 60 Interlock	25
28	18 x 60 Bearing Bottom	26
	KHACHA SERIES	
29	50 X 50 KHACHA	27
30	100 X 30 KHACHA	27

31	100 X 19 KHACHA	28
32	70 X 12 KHACHA	28
33	50 X 25 KHACHA	29
34	75 X 25 KHACHA	29
35	50 X 40 KHACHA	30
36	55 x 40 KHACHA	30
37	50 X 12 KHACHA	31
	DOOR SERIES	
36	Door Middle	32
37	Door TOP	32
38	85 MM DOOR VERTICAL	33
39	Door Vertical	33
40	Door Bottom	34
41	FISH BOTTOM SOLID	34
42	FISH BOUTH	35
43	FISH MOUTH HOLLOW	35
44	FISH BOTTOM	36
45	REL 01	36
46	REL 02	37
	CURTAIN SERIES	
40	50 X 50 Curtain Wall	38
41	45 X 45 Curtain Wall	38
42	63 x 57 Curtain Wall	39
43	2.5 x 1.25 Curtain Wall	39
44	A-1900 Curtain Wall	40
45	DIE NO 7072	40
46	DIE NO 7073	41
47	DIE NO 201201	41
48	DIE NO 201112	42
49	DIE NO 201211	42
50	DIE NO 201111	43
51	DIE NO A-0911	43
52	DIE NO A-0912	44
53	DIE NO A-0918	44
54	DIE NO A-0919	45
	PARTITION SERIES	
55	SINGLE PARTITION	46
56	DOUBLE PARTITION	47
57	SINGLE LEG PARTITION	48
58	2 TRACK SP	48

	RECTANGLE CUBE SERIES	
59	RECTANGLE TUBE	49
	SQUARE TUBE SERIES	
60	SQUARE TUBE	52
61	20 MM SERIES	
62	20 MM HANDLE	53
63	20 MM INTERLOCK	53
64	20 MM TOP BOTTOM	54
65	20 MM HANDLE 2	54
66	20 MM-2 TRACK TOP	55
67	20 MM-2 TRACK BOTTOM	55
68	20 MM-3 TRACK TOP	56
69	20 MM-3 TRACK BOTTOM	56
	12 MM SERIES	
70	12 MM INTERLOCK	57
71	12 MM TOP BOTTOM	57
	25 MM SERIES	
72	25 MM HANDLE	58
73	25 MM INTERLOCK	58
74	25 MM BEARING BOTTOM	59
75	25 MM-2 TRACK TOP	59
76	25 MM-2 TRACK BOTTOM	60
77	1.7 MM THICK 25 MM HANDLE	60
78	1.7 MM THICK 25 MM INTERLOCK	61
79	60 X 25 BEARING BOTTOM	61
	HANDLE SERIES	
80	20 X 50 HANDLE	62
81	43 X 25 HANDLE	62
82	43 X 25 INTERLOCK	63
83	1302 HANDLE	63
84	1303 HANDLE WITH LEG	64
85	20758 HANDLE	64
86	43 X 25 HANDLE 2	65
	TAPPER SERIES	
87	TAPPER HANDLE	66
88	TAPPER GLASS MEETING	66
	'U' CHANNEL SERIES	
89	U CHANNEL	67
90	CLASSIC U CHANNEL	67

	'C' CHANNEL SERIES	
91	C CHANNEL	68
92	WIRING C CHANNEL	68
93	BULB C CHANNEL	69
	ANGLE SERIES	
94	L ANGLE	70
95	34 CLIT ANGLE	71
	KITCHEN SERIES	
96	ROUND KITCHEN	72
97	J SQUARE KITCHEN	72
98	D KITCHEN CABINET	73
99	SQUARE KITCHEN WITH HANDLE	73
100	K-1901	74
101	K-1902	74
102	H-2007	75
103	H-2008	75
104	H-2009	76
105	H-2010	76
106	H-2011	77
107	H-2012	77
108	H-2013	78
109	H-2014	78
110	N-19	79
111	N-20	79
112	N-21	80
113	N-29	80
114	N-30	81
115	N-31	81
116	A-1800	82
117	A-1801	82
118	A-1802	83
119	A-1803	83
120	A-1804	84
121	A-1805	84
122	DIE NO 1304	85
123	DIE NO 1307	85
124	DIE NO 1308	86
	TEXTILE SERIES	
125	TEXTILE 1	87
126	TEXTILE 2	87

127	TEXTILE 3	88
128	TEXTILE 4	88
129	UNIVERSAL	89
130	DIE NO 9028	89
131	DIE NO 9029	90
132	DIE NO 9030	90
133	DIE NO 9031	91
	PHOTOFRAME SERIES	
134	PHOTOFRAME	92
135	Y PHOTOFRAME	92
136	APC PHOTOFRAME	93
137	PHOTOFRAME	93
	FLAT SERIES	
138	ROUND FLAT	94
139	SQUARE FLAT	94
140	BLF-1576	95
	NM SERIES	
141	NM-40	96
142	NM-7004	96
143	NM-7005	97
144	NM-7002	97
145	NM-7003	98
146	NM-7010	98
147	NM-100	99
148	NM-15	99
149	NM-061	100
150	NM-395	100
	SOLAR SERIES	
151	SOLAR C CHANNEL	101
152	SOLAR T CHANNEL	101
153	SOLAR J CHANNEL	102
154	SOLAR Z CLEMP	102
155	SOLAR BRACKET 42 MM	103
156	SOLAR RAILINGS	103
157	64 MM CHANNEL	104
158	59 MM CHANNEL	104
	BFS SERIES	
159	BFS 18 MM ROUND PIPE	105
160	BFS-233	105
161	BFS-236	106

162	BFS-339	106
163	BFS-375	107
164	BFS-379	107
165	BFS-381	108
166	BFS-382	108
167	BFS-383	109
168	BFS-384	109
169	BFS-385	110
170	BFS-386	110
171	BFS-541	111
172	BFS-542	111
173	BFS-552	112
174	BFS-555	112
175	BFS-1097	113
176	BFS-1104	113
177	65 X 65 ANGLE	114
178	110 X 65 ANGLE	114
179	135 X 65 ANGLE	115
180	5" C CHANNLE	115
181	5" D CHANNEL	116
182	6" C CHANNEL	116
183	6" D CHANNEL	117
184	TOWER BOLT	117
185	TOWER BOLT	118
186	TOWER BOLT	118
187	TOWER BOLT	119
	DOMAL SERIES	
188	DIE NO 903	120
189	DIE NO 905	120
190	DIE NO 5005	121
191	DIE NO 5010	121
192	DIE NO 5290	122
193	DIE NO 5291	122
194	DIE NO 5529	123
195	DIE NO 5530	123
196	DIE NO 5531	124
197	DIE NO 5532	124
198	DIE NO 8072	125
199	DIE NO 8273	125
200	DIE NO 8078	126

201	DIE NO 8078-A	126
202	DIE NO 8079	127
203	DIE NO 8079-A	127
204	DIE NO 8082	128
205	DIE NO 8288	128
206	DIE NO 8090	129
207	DIE NO 9004	129
208	DIE NO 9005	130
209	DIE NO 9005-A	130
210	DIE NO 9006	131
211	DIE NO 9007	131
212	DIE NO 9009	132
213	DIE NO 9010	132
214	DIE NO 9011	133
215	DIE NO 9017	133
216	DIE NO 9025	134
217	DIE NO 9027	134
218	DIE NO 9037	135
219	DIE NO 9038	135
220	DIE NO 9041	136
221	DIE NO 9044	136
222	DIE NO 9052	137
223	DIE NO 9053	137
224	DIE NO 9053-A	138
225	DIE NO 9055	138
226	DIE NO 9057	139
227	DIE NO 9067	139
228	DIE NO 9201	140
229	DIE NO 9204	140
230	DIE NO 9205	141
231	DIE NO 9206	141
232	DIE NO 9801	142
233	DIE NO 9803	142
234	DIE NO 9804	143
235	DIE NO 9805	143
236	DIE NO 9807	144
237	DOMAL GLASS MEETING	144
238	KC-003	145
	SVL SERIES	
239	SVL 1	146

240	SVL 2	146
241	SVL 3	147
242	SVL 4	147
243	SVL 5	148
244	SVL 6	148
	HOLLOW SERIES	
245	HOLLOW-2 TRACK TOP	149
246	HOLLOW-2 TRACK BOTTOM	149
247	HOLLOW-3 TRACK TOP	150
248	HOLLOW-3 TRACK BOTTOM	150
249	DIE NO 201213	151
250	DIE NO 201214	151
	MULLION SERIES	
251	MULLION	152
252	MULLION CHAIR	152
253	MULLION Z	153
254	MULLION CLIP	153
	LOUVER SERIES	
255	3" 2 LOUVER [1305]	154
256	DIE NO 1333	154
	OVAL SERIES	
257	OVAL SECTION	155
	'L' PIPE SERIES	
258	2 X 1 L PIPE	156
259	1.5 X 1 L PIPE	156
260	2.5 X 1.5 L PIPE	157
	OTHER	
261	BULB T	158
262	DGC	158
263	GLAZZING CLIP	159
264	1" HALF ROUND	159
265	50 MM HANDLE WITH BULB	160
266	BIG MESH NET	160
267	D.C.M	161
268	DOOR C GEAR	161
269	DOOR G GEAR	162
270	DRAWER SECTION	162
271	FLOWER BRACKET	163
272	GLAZZING PATTA	163
273	H SECTION	164

274	J WATER CHANNEL	164
275	KEY GOLA	165
276	MESH NET	165
277	SHOWCASE	166
278	SHOWCASE WITH LEG	166
279	STEP EDGE	167
280	T WITHOUT BULB	167
281	TRANSPORT F	168
282	TRANSPORT H	168
283	TVS WATER CHANNEL	169
284	V CLIP	169
285	VOLVO HALF ROUND	170
286	DIE NO A-0914	170
287	DIE NO A-0915	171
288	DIE NO A-0916	171
289	DIE NO A-0922	172
290	DIE NO A-0923	172
291	DIE NO 0922	173
292	DIE NO A-0921	173
293	DIE NO 20121	174
294	DIE NO 201212	174
295	DIE NO 201215	175
296	DIE NO 201216	175
297	DIE NO 201217	176
298	DIE NO 201218	176
299	DIE NO 0924	177
300	DIE NO 0900	177
301	DIE NO 6920 [DGU]	178
302	DIE NO 6921 [SGU]	178
303	FOOTPRINT	179
304	TRPT MAZDA BEEDING	179
305	DIE NO 0909	180
306	S1	180
307	S2	181
308	M2	181
309	GRILL-F	182
310	20 MM HANDLE 3	182
311	DIE NO 0901	183
312	DIE NO 0932	183
313	DIE NO 0927	184

314	DIE NO 0925	184
315	6 MM ROD	185
316	19 MM ROD	185
317	18 MM FR PIPE	186
318	30 MM PR PIPE	186
319	K-7152	187
320	K-7151	187

3/4 SERIES

SINGLE TRACK TOP

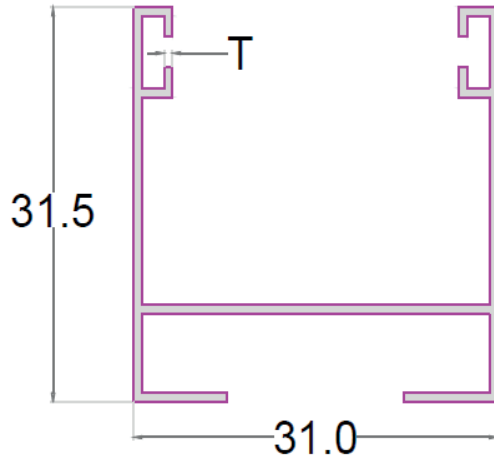

SL NO.	SECTION NO	T	WEIGHT RANGE KG/12'
1	1001	0.70	0.900-1.100

SINGLE TRACK BOTTOM

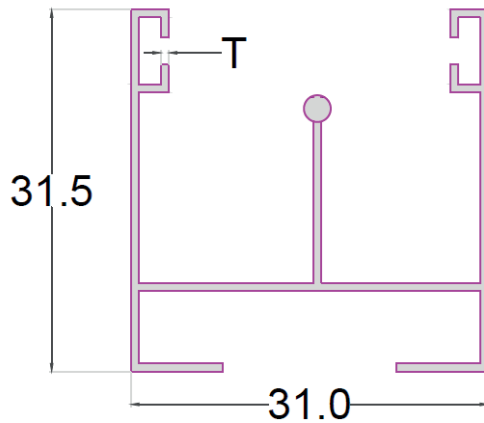

SL NO.	SECTION NO	T	WEIGHT RANGE KG/12'
1	1002	0.70	0.900-1.000

2 TRACK TOP

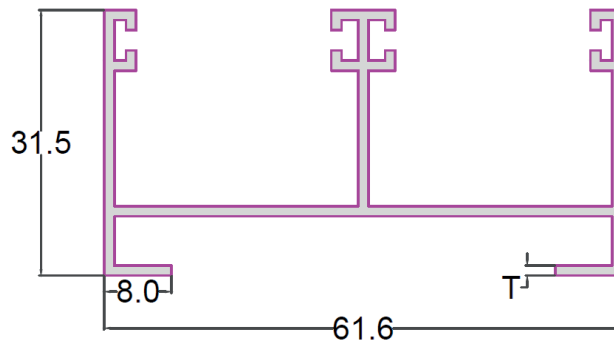

SL NO.	SECTION NO	T	WEIGHT RANGE KG/12'
1	1003	0.68	1.400-1.600
2	1004	0.83	1.700-1.900
3	1005	0.99	2.000-2.200
4	1006	1.10	2.500-2.700
5	1007	1.50	3.000-3.200
6	1008	1.60	3.200-3.400

2 TRACK BOTTOM

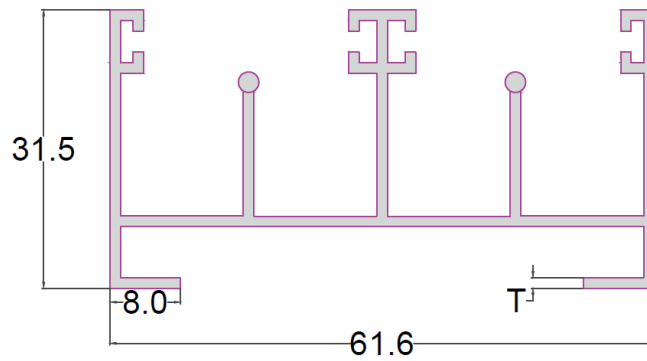

SL NO.	SECTION NO	T	WEIGHT RANGE KG/12'
1	1009	0.74	1.700-1.900
2	1010	0.85	2.000-2.200
3	1011	1.40	3.000-3.200
4	1012	1.50	3.300-3.500

3 TRACK TOP

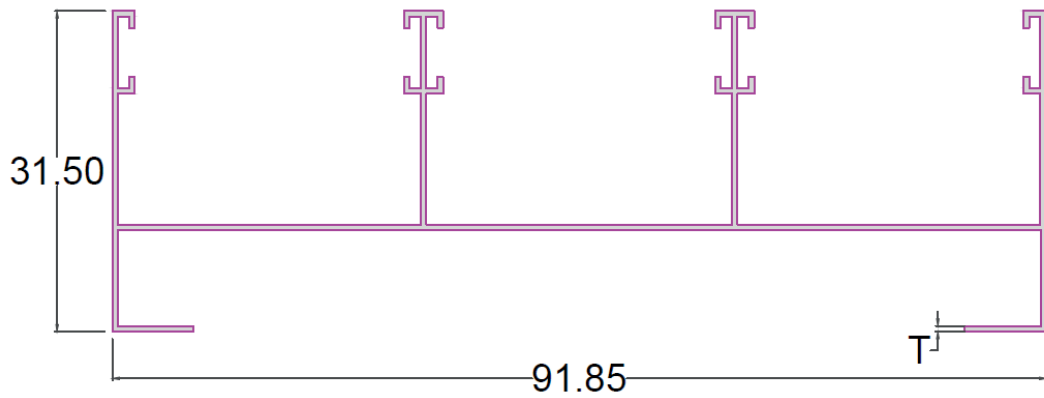

SL NO.	SECTION NO	T	WEIGHT RANGE KG/12'
1	1013	0.60	1.800-2.000
2	1014	0.70	2.000-2.200
3	1015	0.90	2.800-3.000
4	1016	1.20	3.500-4.000

3 TRACK BOTTOM

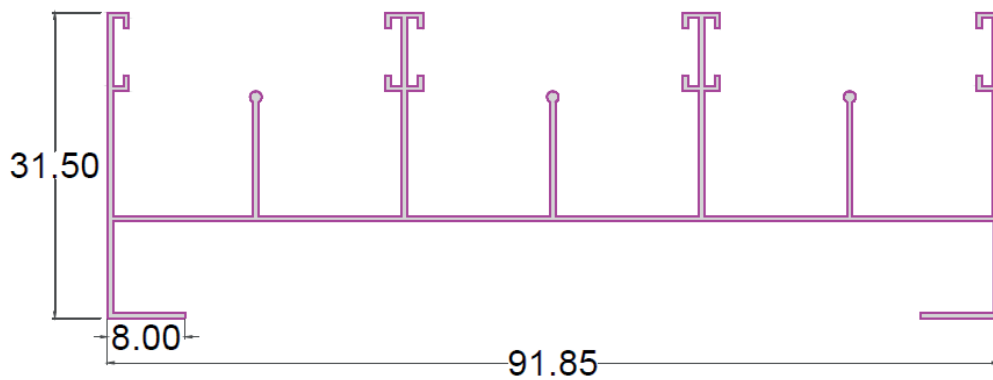

SL NO.	SECTION NO	T	WEIGHT RANGE KG/12'
1	1017	0.58	2.000-2.400
2	1018	0.79	2.600-2.800
3	1019	0.93	3.000-3.300
4	1020	1.30	3.500-4.000
5	1021	1.50	4.000-4.450

4 TRACK TOP

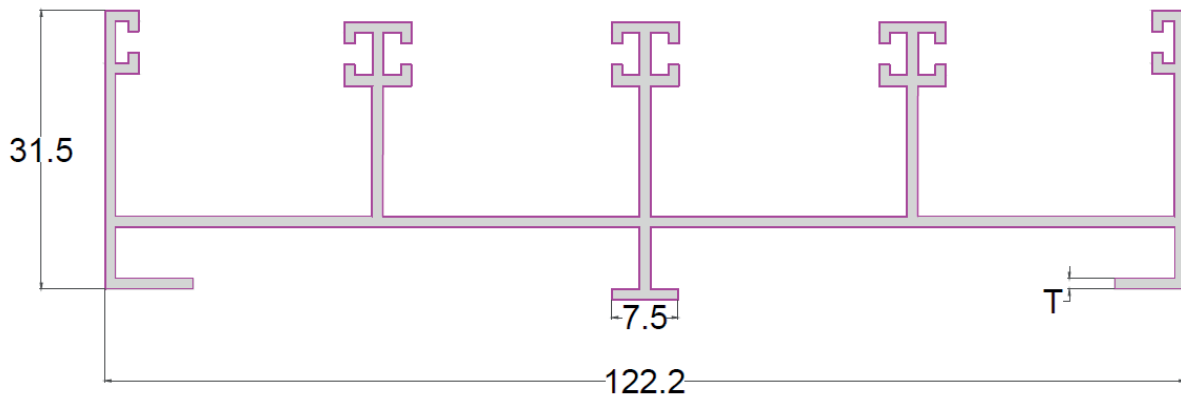

SL NO.	SECTION NO	T	WEIGHT RANGE KG/12'
1	1022	0.78	3.000-3.300

4 TRACK BOTTOM

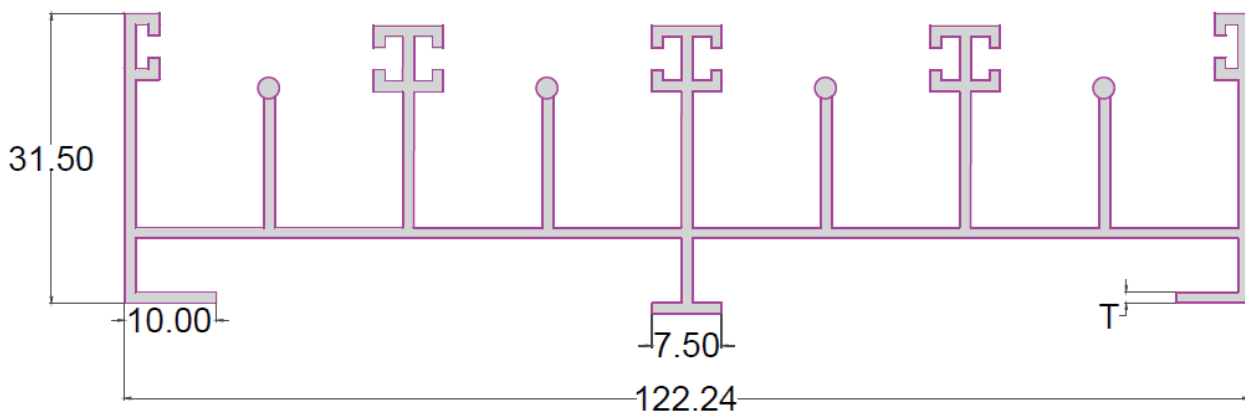

SL NO.	SECTION NO	T	WEIGHT RANGE KG/12'
1	1023	1.00	4.000-4.500

5 TRACK TOP

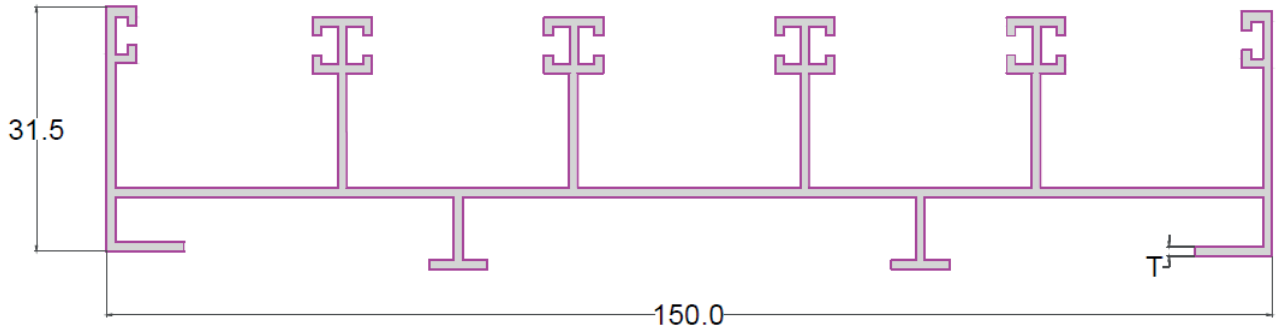

SL NO.	SECTION NO	T	WEIGHT RANGE KG/12'
1	1024	1.15	5.000-5.500

5 TRACK BOTTOM

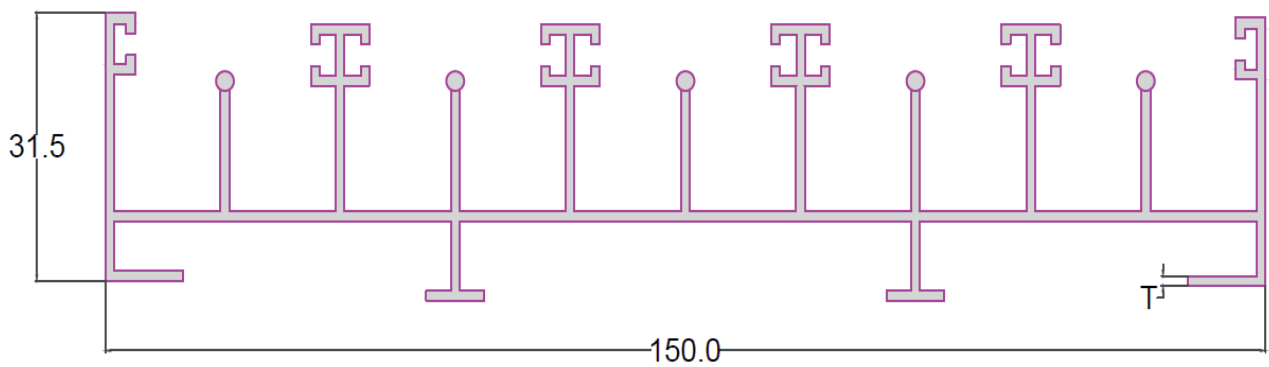

SL NO.	SECTION NO	T	WEIGHT RANGE KG/12'
1	1025	1.20	7.000-7.200

¾ HANDLE

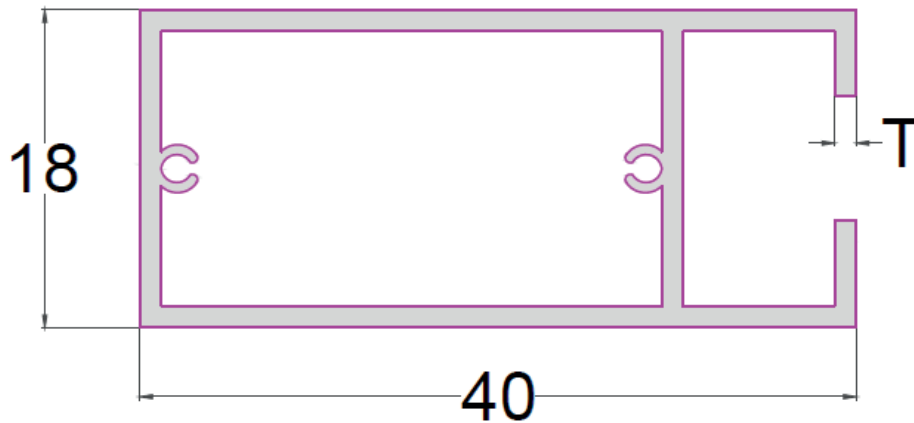

SL NO.	SECTION NO	T	WEIGHT RANGE KG/12'
1	1026	0.67	0.900-1.000
2	1027	0.75	1.000-1.200
3	1028	0.90	1.200-1.400
4	1029	1.22	1.600-1.800
5	1030	1.40	1.900-2.300

¾ TOP BOTTOM

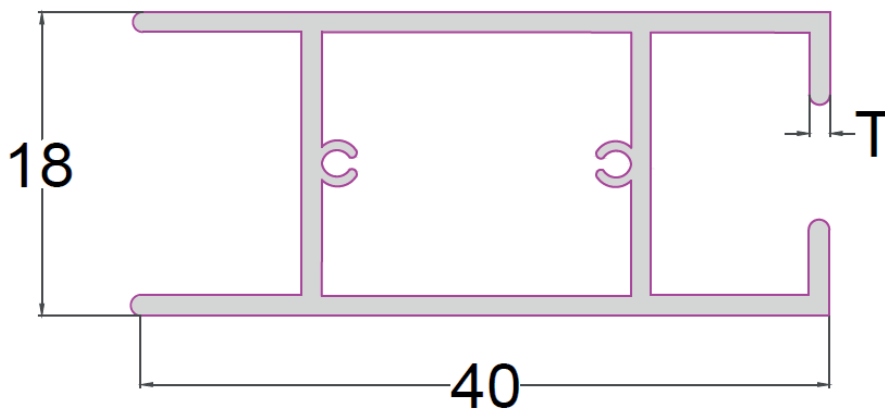

SL NO.	SECTION NO	T	WEIGHT RANGE KG/12'
1	1031	0.60	0.900-1.000
2	1032	0.70	1.000-1.200
4	1033	0.90	1.300-1.500
5	1034	1.30	1.600-1.800
6	1035	1.70	2.300

¾ INTERLOCK

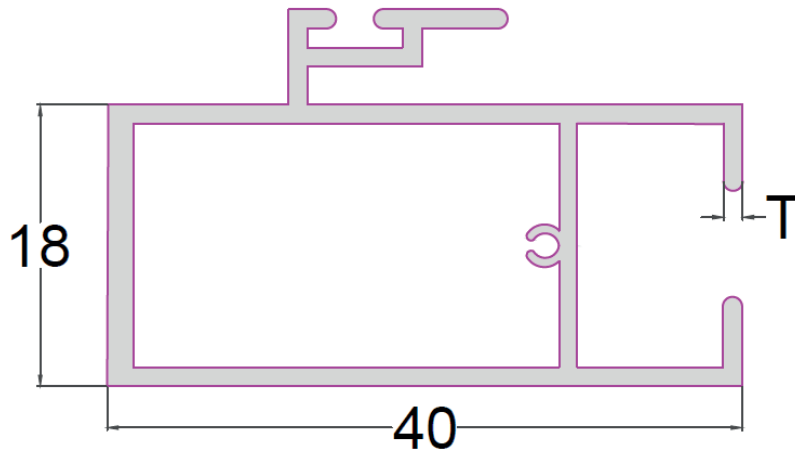

SL NO.	SECTION NO	T	WEIGHT RANGE KG/12'
1	1036	0.74	1.150-1.300
2	1037	0.82	1.300-1.500
3	1038	0.96	1.500-1.600
4	1039	1.17	1.800-2.000
5	1040	1.60	2.300-2.500

¾ BEARING BOTTOM

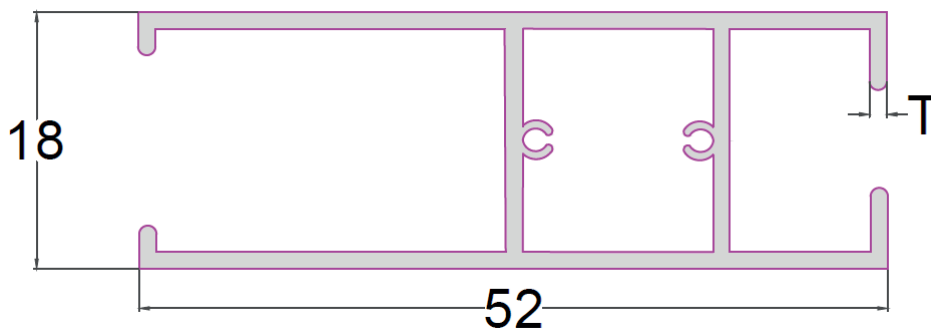

SL NO.	SECTION NO	T	WEIGHT RANGE KG/12'
1	1041	0.80	1.300-1.500
2	1042	0.99	1.600-1.800
3	1043	1.00	2.000

¾ GLASS MEETING

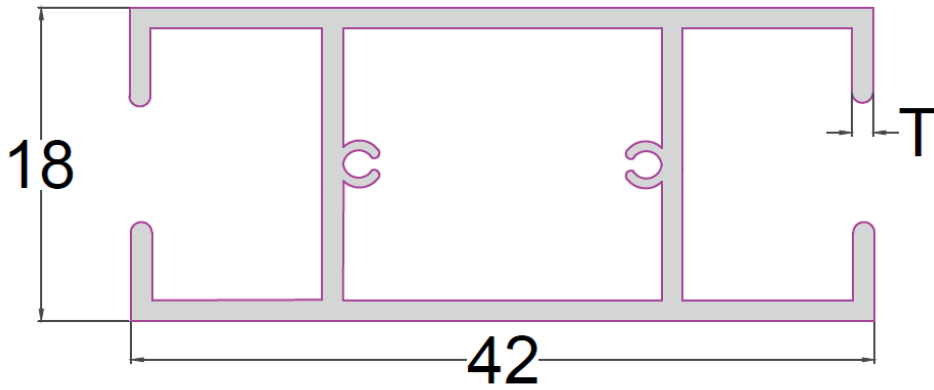

SL NO.	SECTION NO	T	WEIGHT RANGE KG/12'
1	1044	0.70	1.000-1.250
2	1045	1.00	1.400-1.600

1" SERIES

2 TRACK TOP

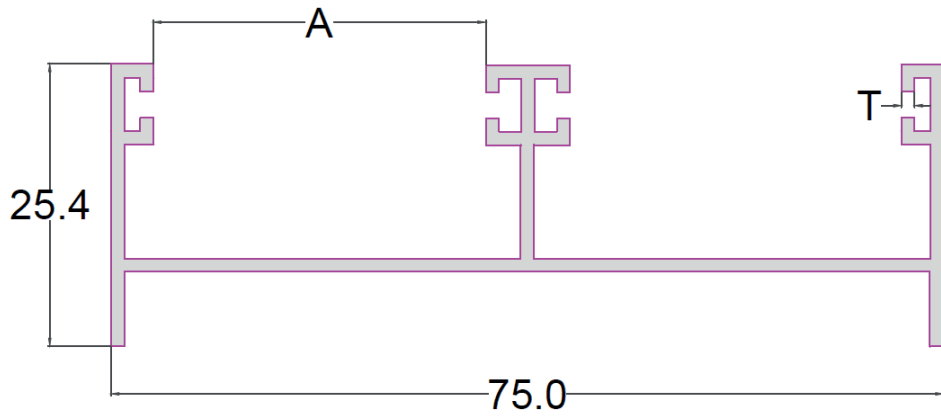

SL NO.	SECTION NO	A	T	WEIGHT RANGE KG/12'
1	1046	29.10	1.40	2.760

2 TRACK BOTTOM

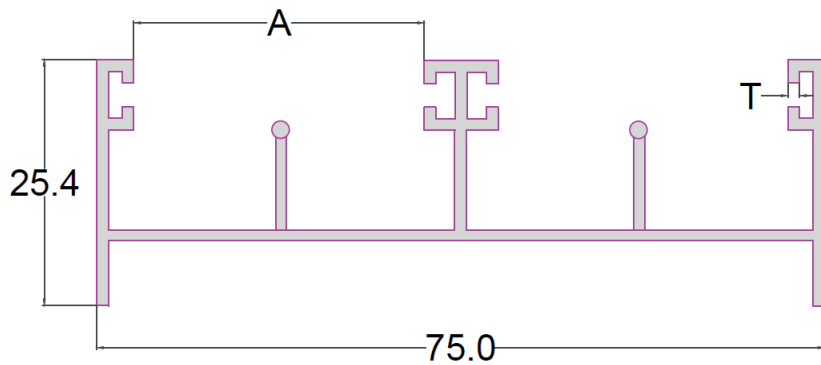

SL NO.	SECTION NO	A	T	WEIGHT RANGE KG/12'
1	1047	29.10	1.35	2.700

3 TRACK TOP

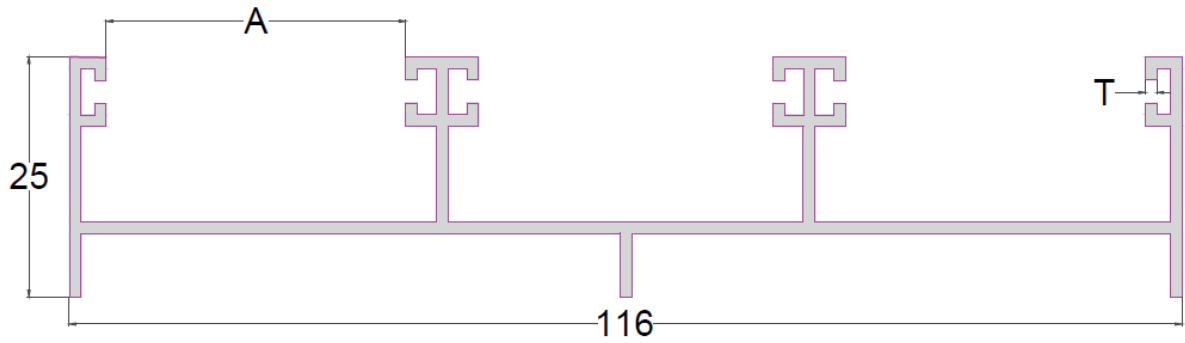

SL NO.	SECTION NO	A	T	WEIGHT RANGE KG/12'
1	1048	30.20	1.25	3.480

3 TRACK BOTTOM

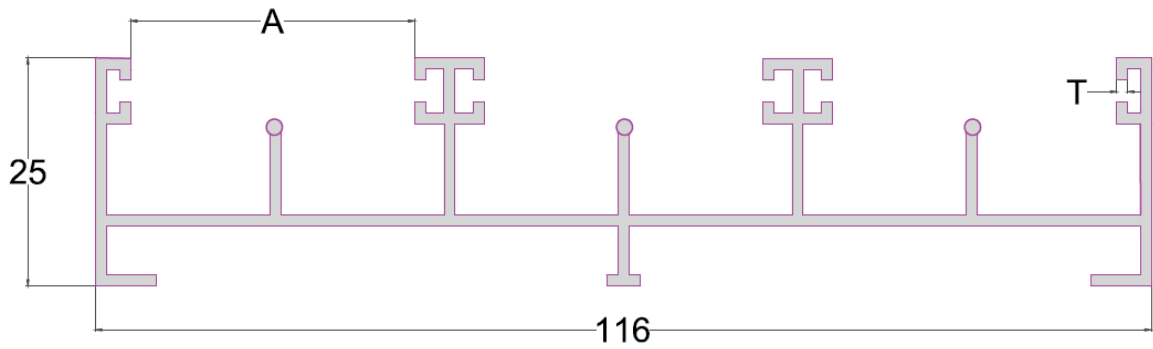

SL NO.	SECTION NO	A	T	WEIGHT RANGE KG/12'
1	1049	30.20	1.35	4.340

1" HANDLE

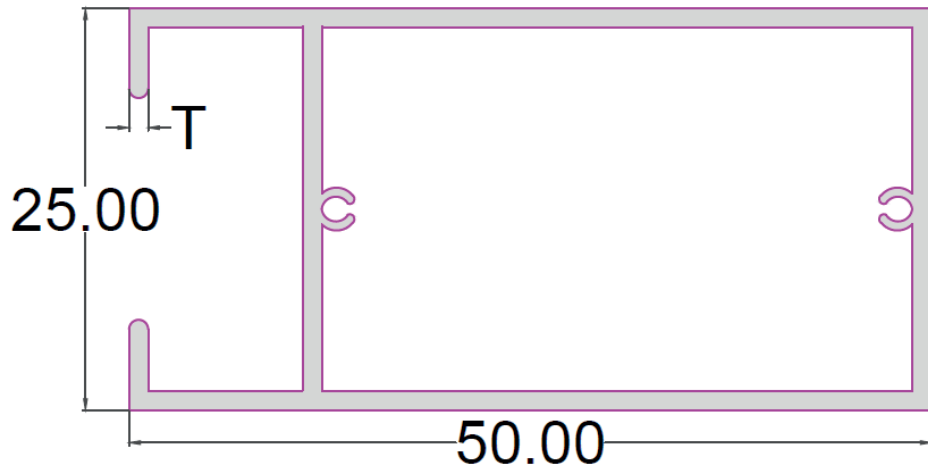

SL NO.	SECTION NO	T	WEIGHT RANGE KG/12'
1	1050	0.90	1.600-1.700
2	1051	1.20	2.000-2.200
3	1052	1.40	2.400-2.600

1" INTERLOCK

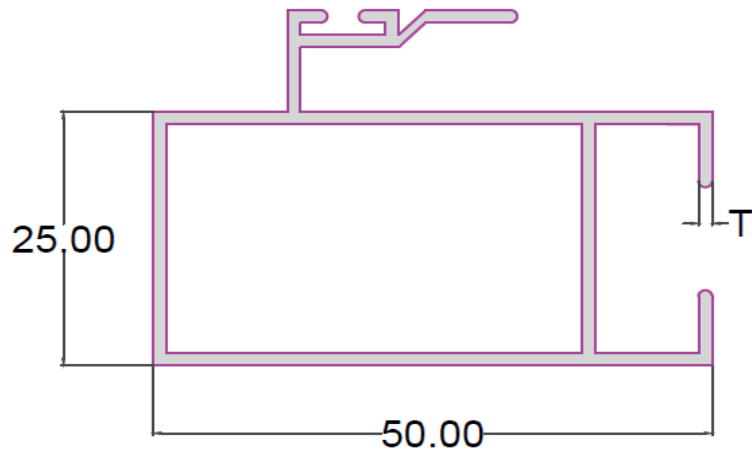

SL NO.	SECTION NO	T	WEIGHT RANGE KG/12'
1	1053	1.30	2.400-2.600

1" GLASS MEETING

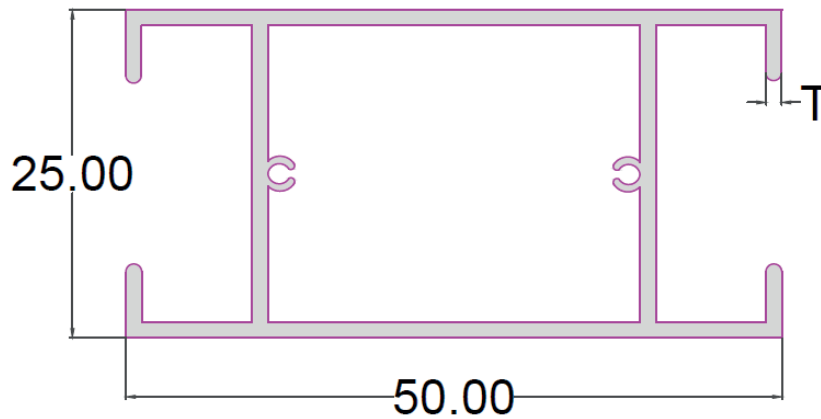

SL NO.	SECTION NO	T	WEIGHT RANGE KG/12'
1	1054	1.15	2.100-2.300

1" SQUARE TUBE WITH 1 LIP

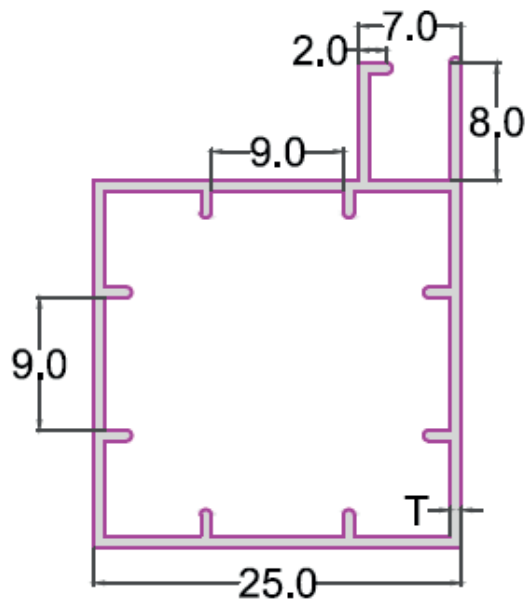

SL NO.	SECTION NO	T	WEIGHT RANGE KG/12'
1	1055	0.75	0.900-1.000

1" SQUARE TUBE WITH 2 LIP

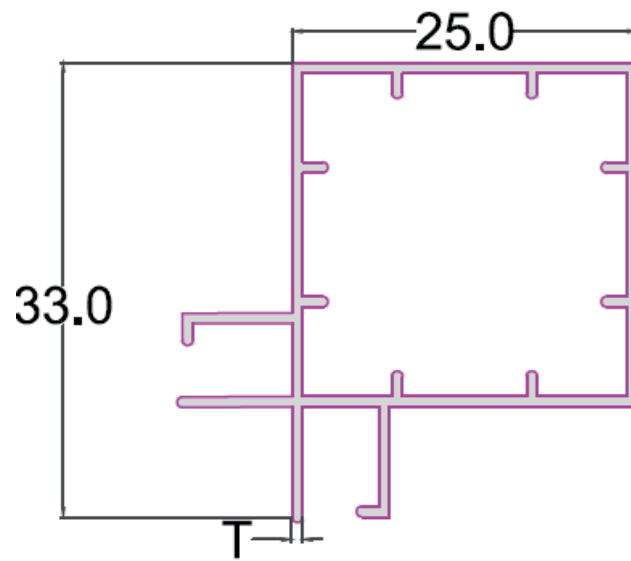

SL NO.	SECTION NO	T	WEIGHT RANGE KG/12'
1	1056	0.80	1.000-1.200

18 X 50 SERIES

18 X 50 HANDLE

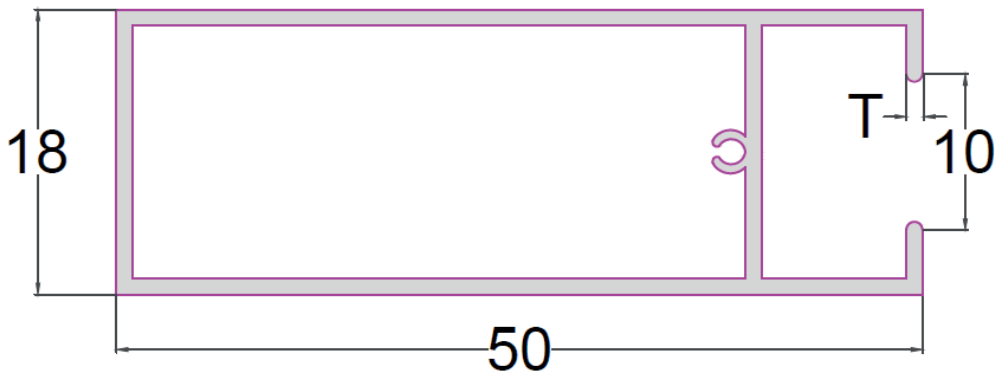

SL NO.	SECTION NO	T	WEIGHT RANGE KG/12'
1	1057	1.40	1.900-2.100

18 X 50 INTERLOCK

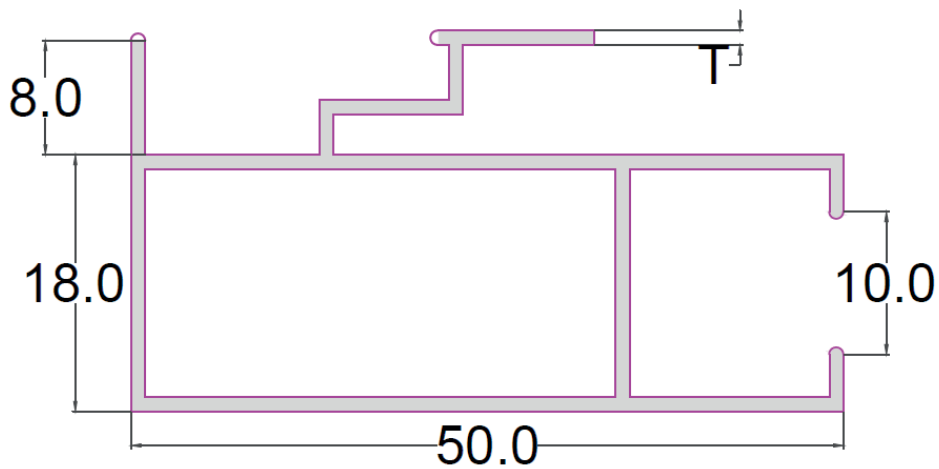

SL NO.	SECTION NO	T	WEIGHT RANGE KG/12'
1	1058	0.90	1.350-1.500
2	1059	1.40	1.900-2.200

18 X 60 SERIES

18 X 60 HANDLE

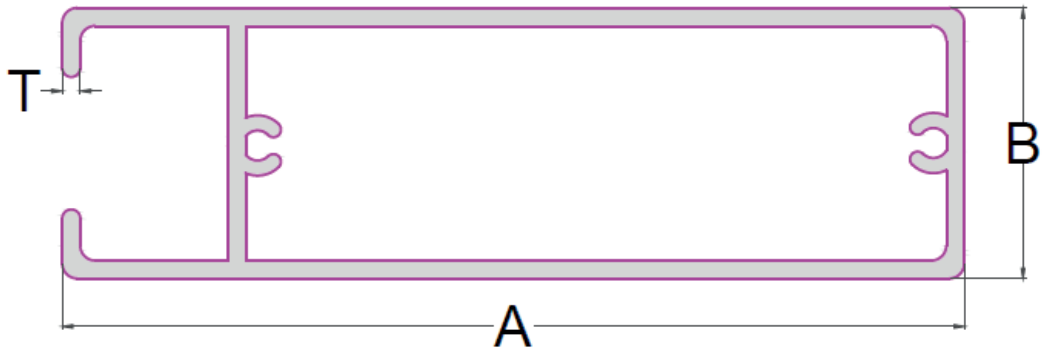

SL NO.	SECTION NO	A	B	T	WEIGHT RANGE KG/12'
1	1060	60.00	18.00	1.20	1.900-2.100

18 X 60 INTERLOCK

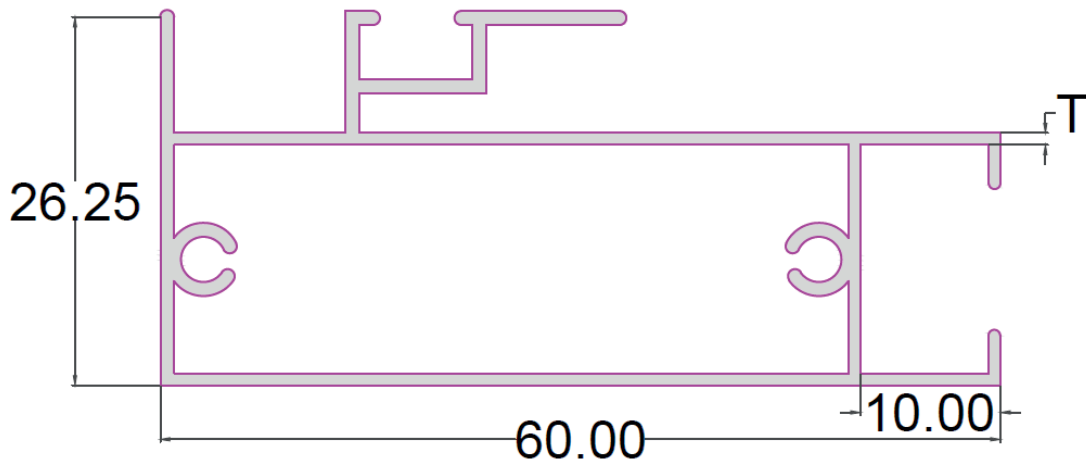

SL NO.	SECTION NO	T	WEIGHT RANGE KG/12'
1	1061	1.40	1.900-2.100

18 X 60 BEARING BOTTOM

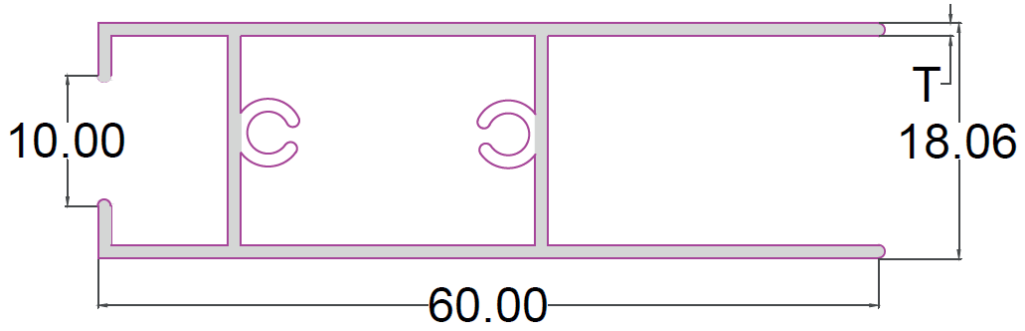

SL NO.	SECTION NO	T	WEIGHT RANGE KG/12'
1	1062	1.40	2.100-2.200

KHACHA SERIES

50 X 50 KHACHA

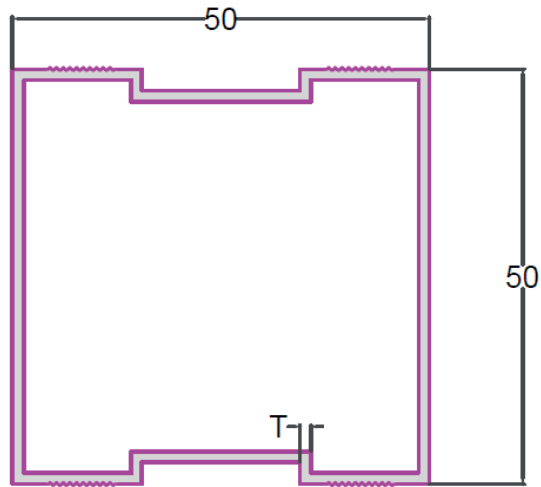

SL NO.	SECTION NO	T	WEIGHT RANGE KG/12'
1	1063	1.29	2.800-3.000
2	1064	1.75	3.700-3.900
3	1065	2.24	4.700-4.900

100 X 30 KHACHA

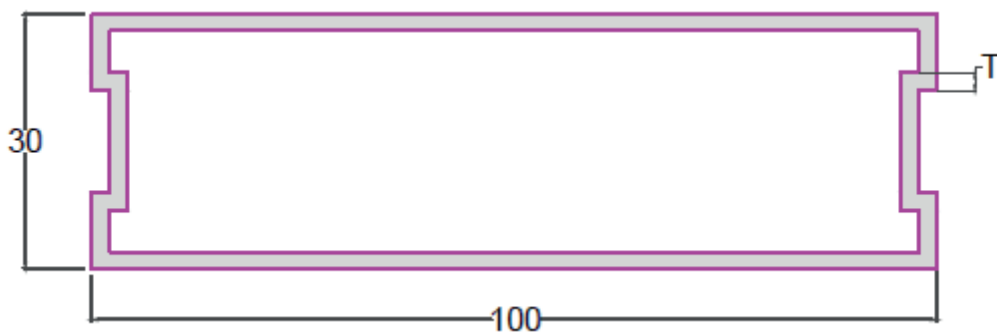

SL NO.	SECTION NO	T	WEIGHT RANGE KG/12'
1	1066	1.90	5.200-5.400
2	1067	2.41	6.500-6.700

100 X 19 KHACHA

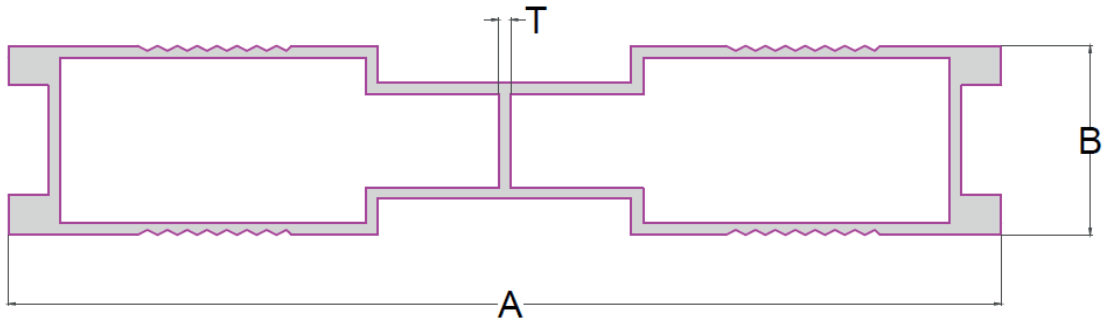

SL NO.	SECTION NO	A	B	T	WEIGHT RANGE KG/12'
1	1068	100.00	19.00	1.26	3.300-3.500
2	1069	100.00	19.00	1.46	3.800-4.000

70 X 12 KHACHA

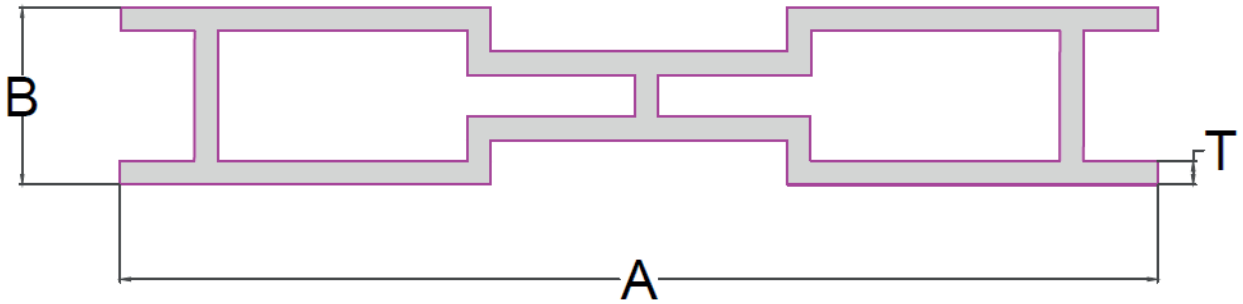

SL NO.	SECTION NO	A	B	T	WEIGHT RANGE KG/12'
1	1070	70.00	12.00	1.12	2.100-2.300
2	1071	70.00	12.00	1.50	2.800-3.000
3	1072	70.00	12.00	1.91	3.600-3.800

50 X 25 KHACHA

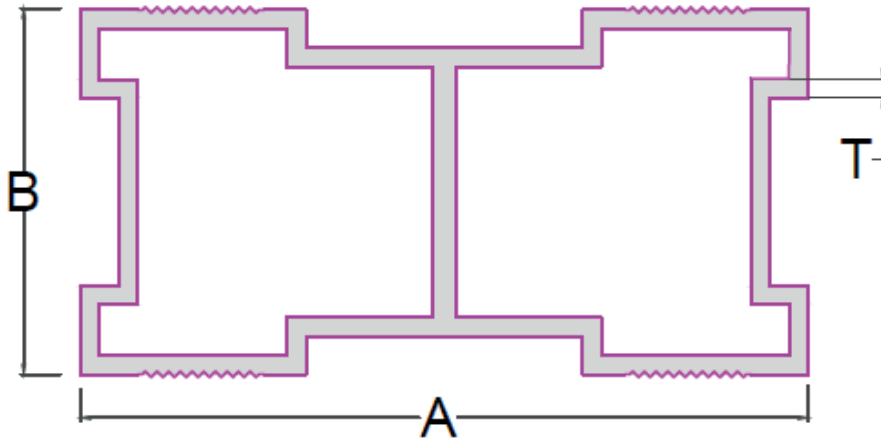

SL NO.	SECTION NO	A	B	T	WEIGHT RANGE KG/12'
1	1073	50.00	25.00	1.63	2.800-3.000

75 X 25 KHACHA

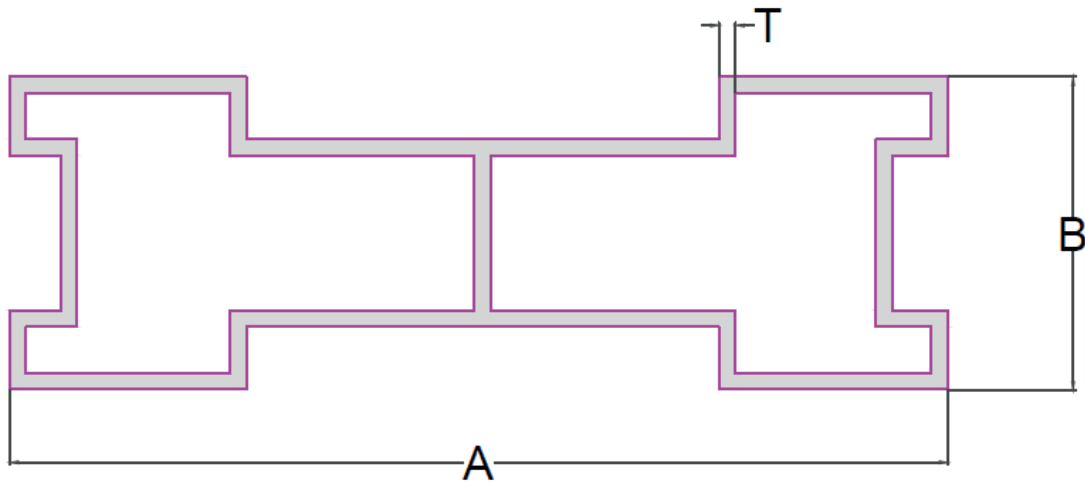

SL NO.	SECTION NO	A	B	T	WEIGHT RANGE KG/12'
1	1074	75.00	25.00	1.64	3.700-3.900

50 X 40 KHACHA

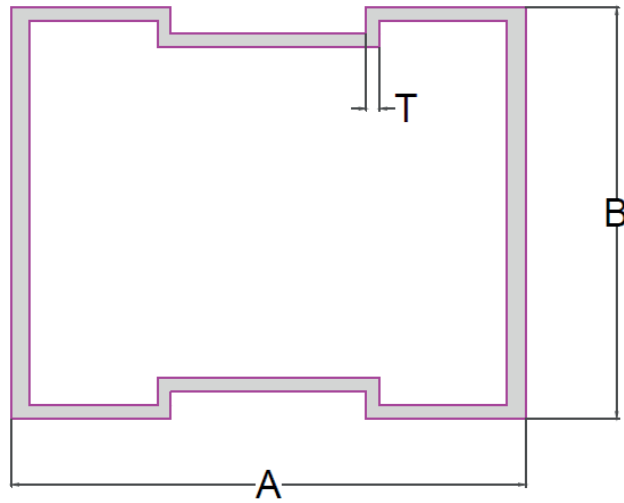

SL NO.	SECTION NO	A	B	T	WEIGHT RANGE KG/12'
1	1075	50.00	40.00	1.68	3.200-3.400
2	1076	50.00	40.00	1.98	3.800-4.000

55 X 40 KHACHA

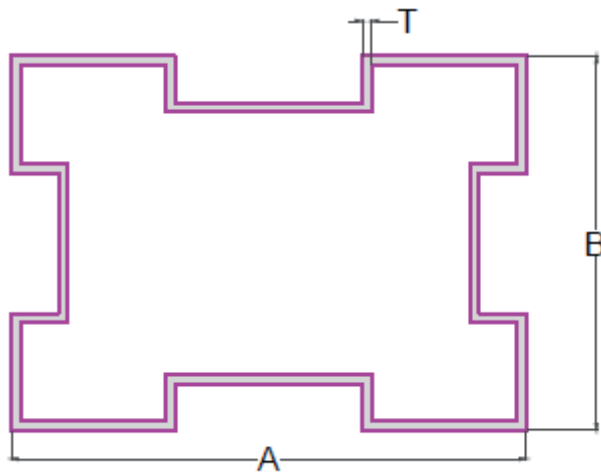

SL NO.	SECTION NO	A	B	T	WEIGHT RANGE KG/12'
1	1077	55.00	40.00	1.89	4.000-4.300

50 X 12 KHACHA

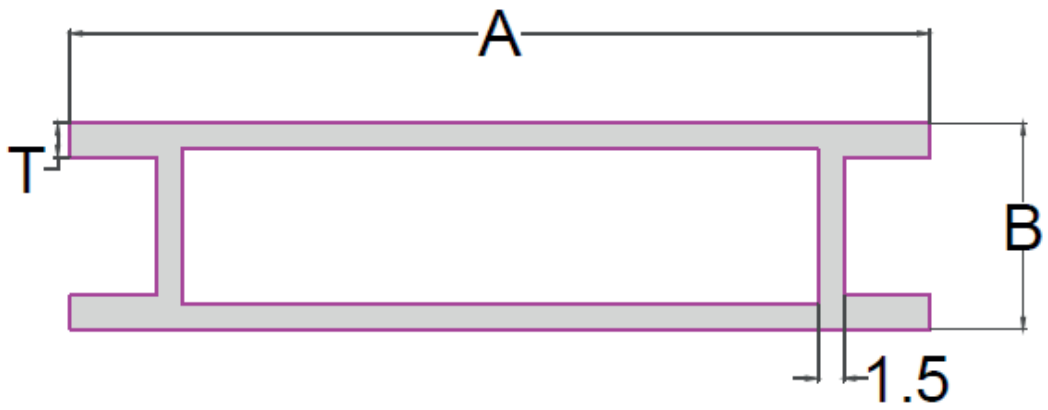

SL NO.	SECTION NO	A	B	T	WEIGHT RANGE KG/12'
1	1078	50.00	12.00	1.57	2.100-2.300

DOOR SERIES

DOOR MIDDLE

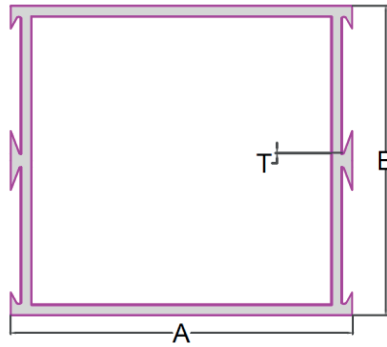

SL NO.	SECTION NO	A	B	T	WEIGHT RANGE KG/12'
1	1079	47.00	44.45	1.17	2.000-2.600
2	1080	47.00	44.45	2.30	6.200-6.600

DOOR TOP

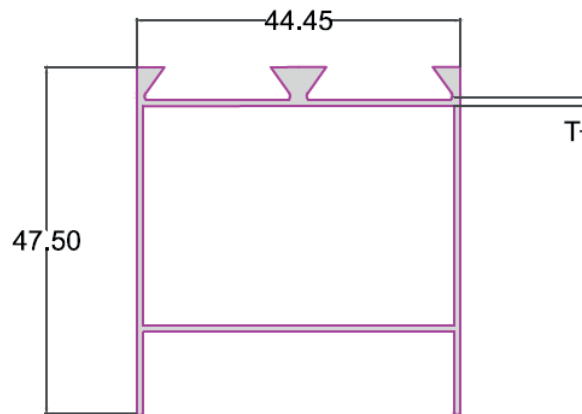

SL NO.	SECTION NO	T	WEIGHT RANGE KG/12'
1	1081	1.00	2.000-2.200
2	1082	1.43	2.800-3.000
3	1083	2.00	5.200-5.500

85 MM DOOR VERTICAL

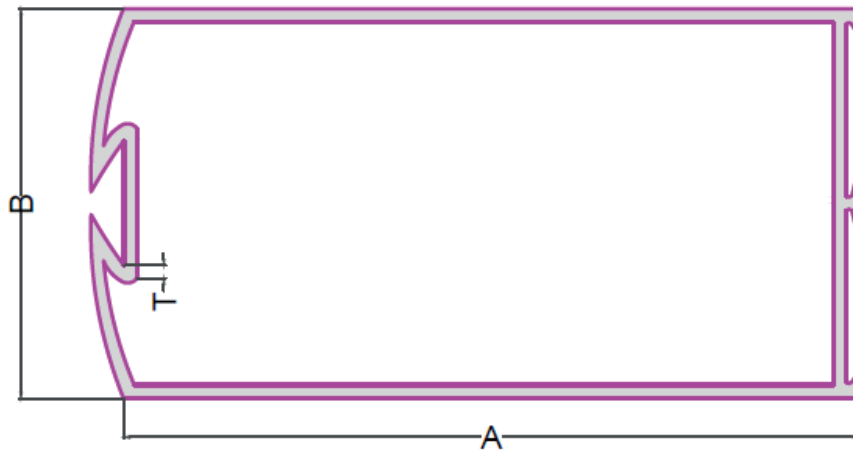

SL NO.	SECTION NO	A	B	T	WEIGHT RANGE KG/12'
1	1084	85.00	42.20	0.74	1.700-1.900
2	1085	85.00	42.20	1.76	4.300-4.500

DOOR VERTICAL

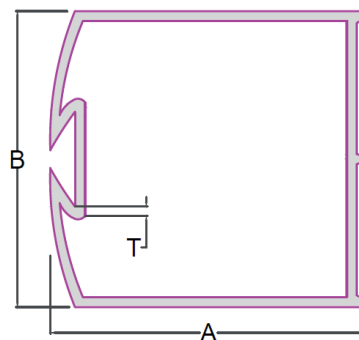

SL NO.	SECTION NO	A	B	T	WEIGHT RANGE KG/12'
1	1086	47.00	44.45	0.70	1.400-1.600
2	1087	47.00	44.45	0.90	1.700-2.000
3	1088	47.00	44.45	1.70	3.200-3.400

DOOR BOTTOM

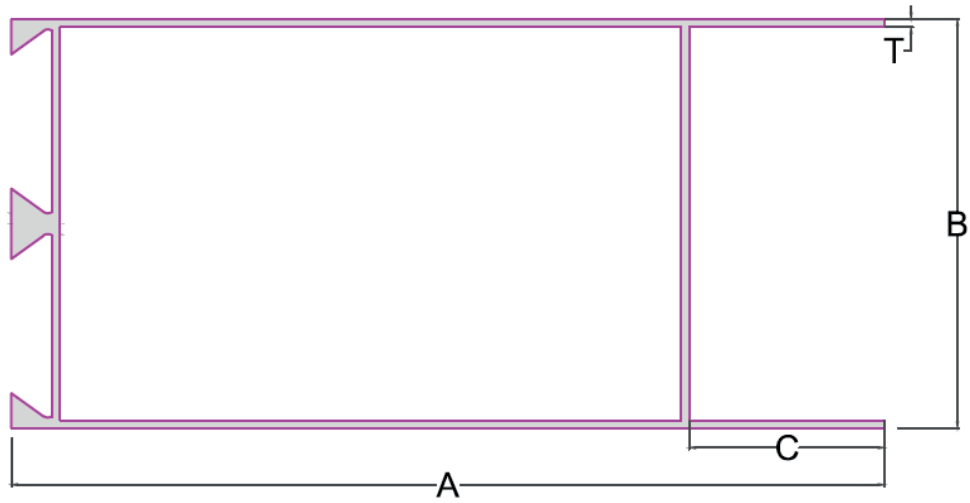

SL NO.	SECTION NO	A	B	C	T	WEIGHT RANGE KG/12'
1	1089	88.90	44.45	10.15	1.07	3.000-3.300
2	1090	114.30	44.45	10.15	1.52	4.600-4.800

FISH BOTTOM SOLID

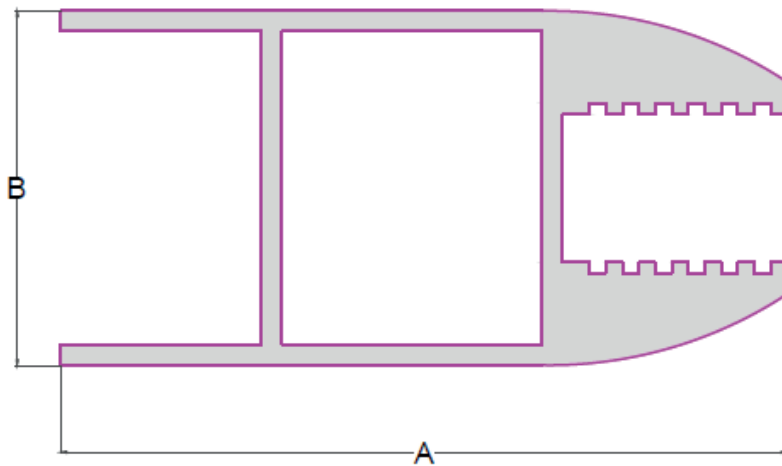

SL NO.	SECTION NO	A	B	WEIGHT RANGE KG/12'
1	1091	88.00	43.12	8.500-9.000

FISH MOUTH

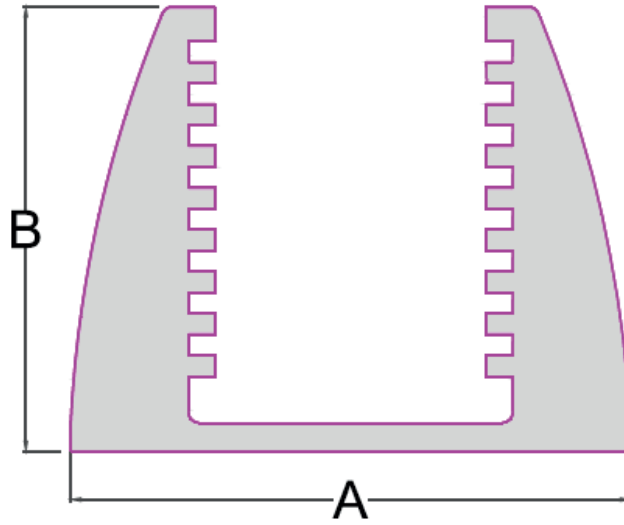

SL NO.	SECTION NO	A	B	WEIGHT RANGE KG/12'
1	1092	40.00	31.75	4.00-4.200
2	1093	40.00	31.75	5.000-5.200

FISH MOUTH HOLLOW

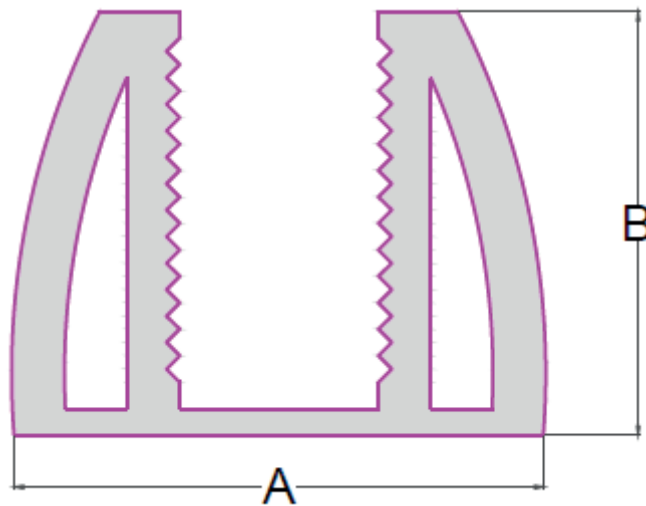

SL NO.	SECTION NO	A	B	WEIGHT RANGE KG/12'
1	1094	40.00	32.00	3.000-3.300
2	1095	40.00	32.00	3.800-4.000

FISH BOTTOM

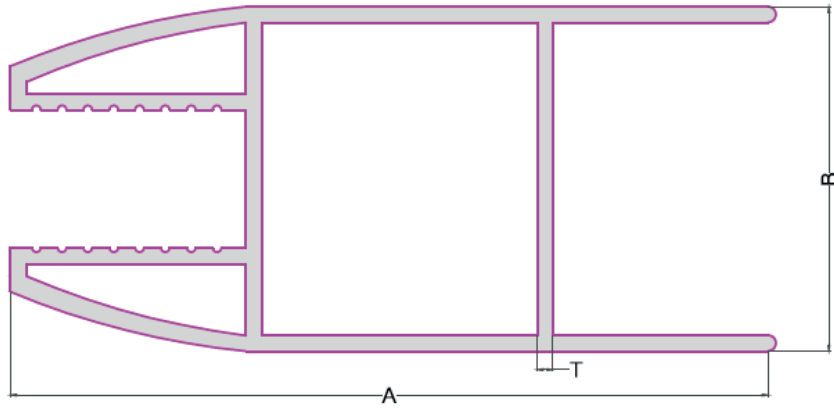

SL NO.	SECTION NO	A	B	T	WEIGHT RANGE KG/12'
1	1096	88.00	40.00	1.83	4.500-4.800
2	1097	88.00	40.00	1.90	5.000-5.400

REL 01

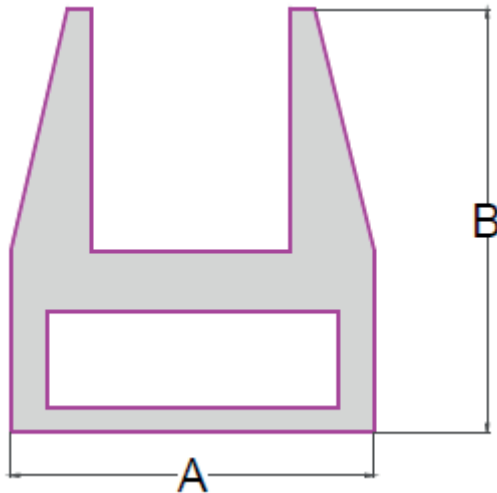

SL NO.	SECTION NO	A	B	WEIGHT RANGE KG/12'
1	1098	30.00	35.00	6.000-6.200

REL 02

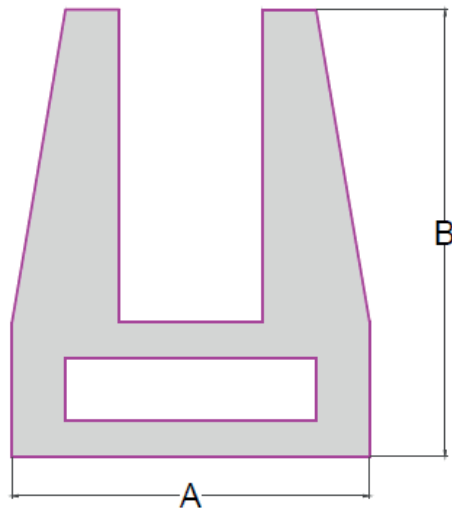

SL NO.	SECTION NO	A	B	WEIGHT RANGE KG/12'
1	1099	40.00	50.00	9.800-10.000

CURTAIN SERIES

50 X 50 CURTAIN WALL

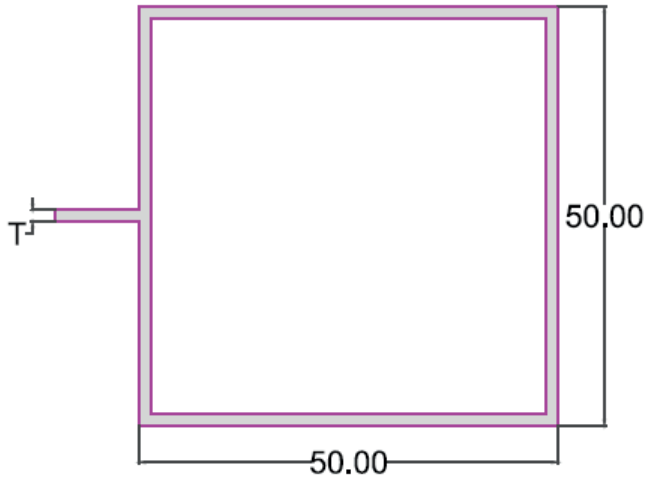

SL NO.	SECTION NO	T	WEIGHT RANGE KG/12'
1	1100	2.00	3.000-3.200

45 X 45 CURTAIN WALL

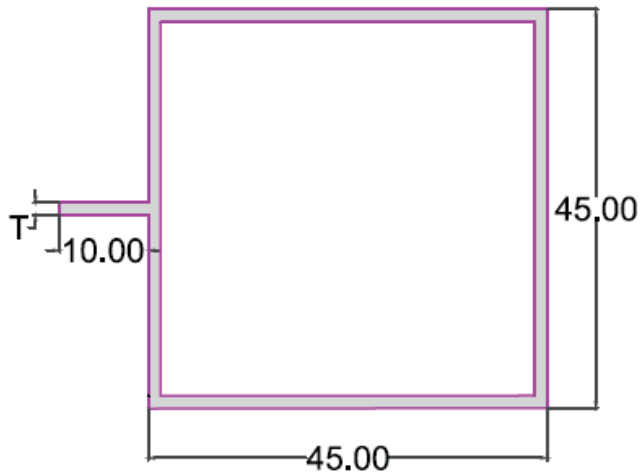

SL NO.	SECTION NO	T	WEIGHT RANGE KG/12'
1	1101	1.30	2.200-2.500

63 X 57 CURTAIN WALL

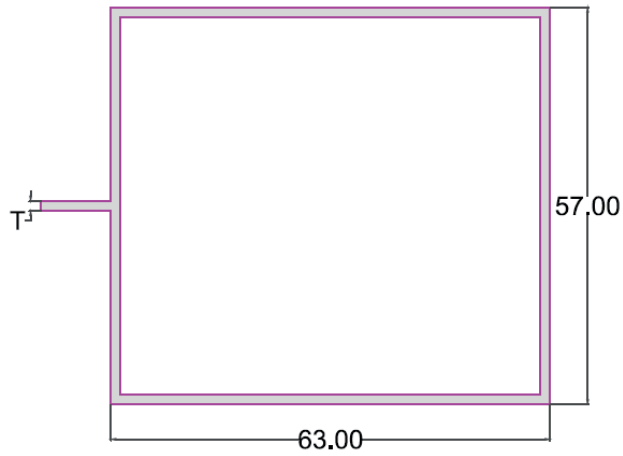

SL NO.	SECTION NO	T	WEIGHT RANGE KG/12'
1	1102	1.60	4.000-4.200
2	1103	2.40	6.000-6.200

2.5 X 1.25 CURTAIN WALL

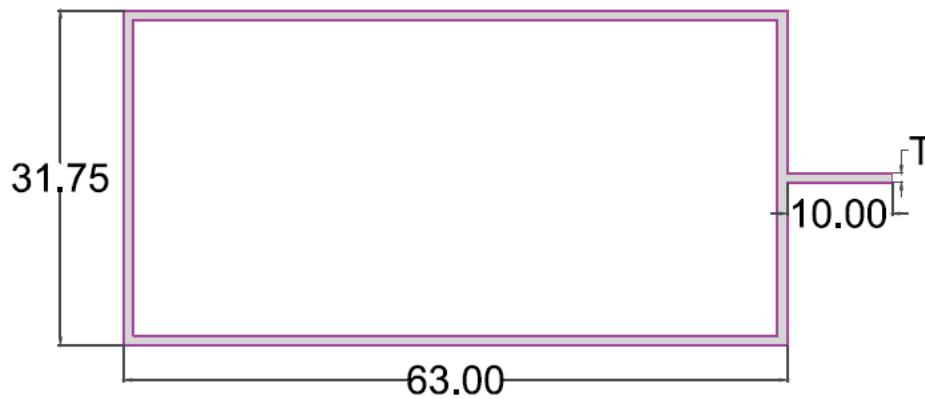

SL NO.	SECTION NO	T	WEIGHT RANGE KG/12'
1	1104	0.90	1.800-2.000
2	1105	1.00	2.000-2.300
3	1106	1.15	2.300-2.500
4	1107	1.30	2.500-2.700

A-1900 CURTAIN WALL

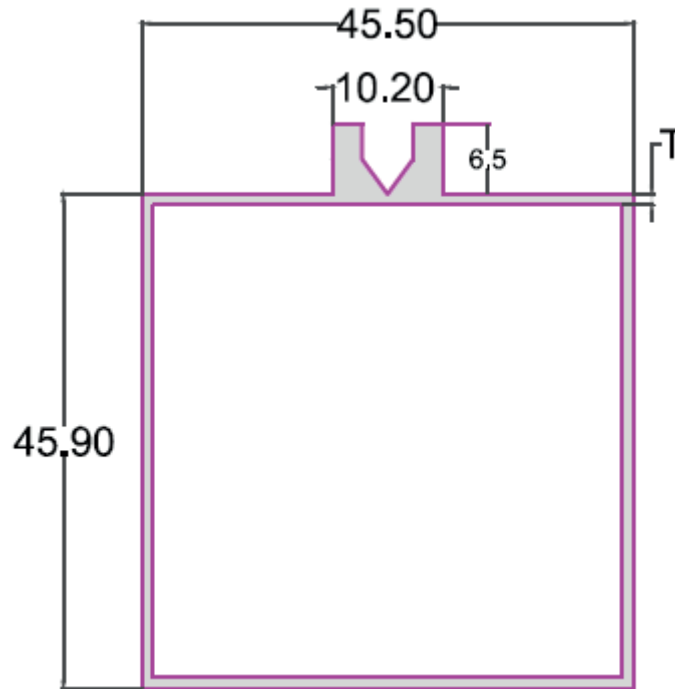

SL NO.	SECTION NO	T	WEIGHT RANGE KG/12'
1	1108	1.00	2.000-2.200

DIE NO 7072

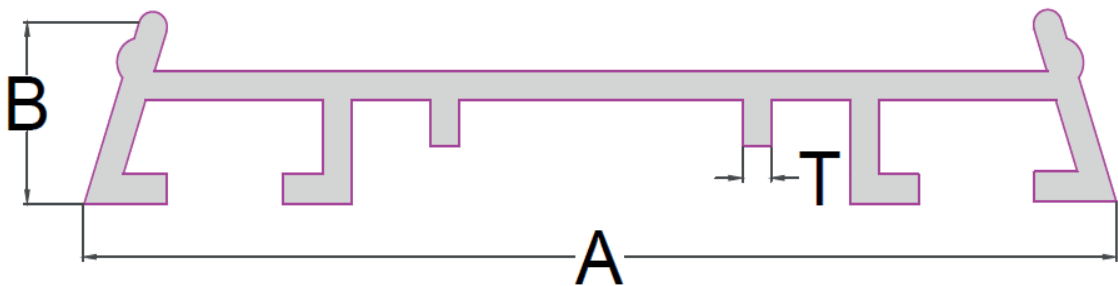

SL NO.	SECTION NO	A	B	T	WEIGHT RANGE KG/12'
1	1109	53.45	9.50	4.00	2.000-2.400

DIE NO 7073

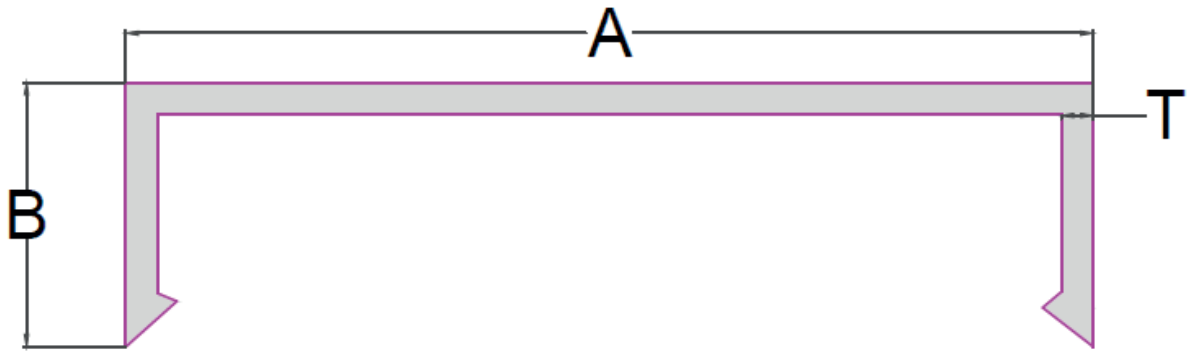

SL NO.	SECTION NO	A	B	T	WEIGHT RANGE KG/12'
1	1110	55.00	15.00	1.80	1.200-1.500

DIE NO 201201

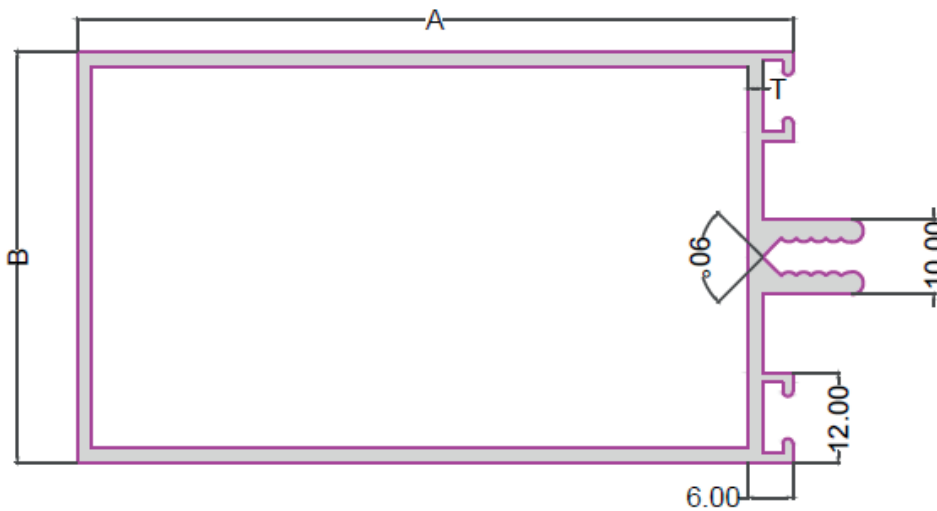

SL NO.	SECTION NO	A	B	T	WEIGHT RANGE KG/12'
1	1111	96.00	55.00	2.00	6.500-6.700

DIE NO 201112

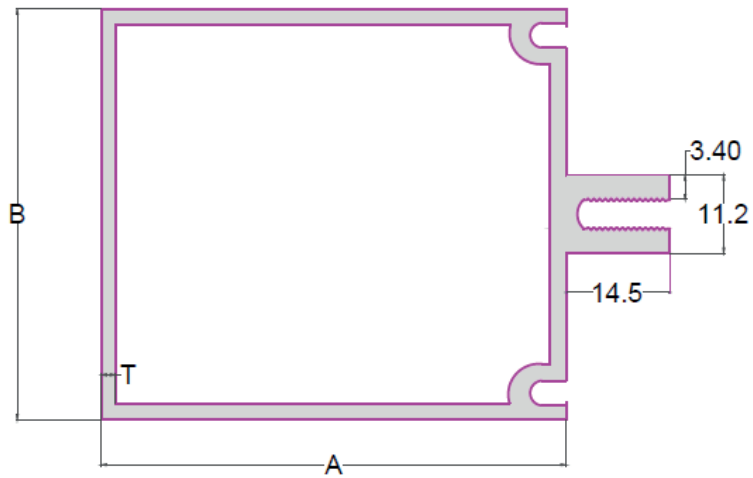

SL NO.	SECTION NO	A	B	T	WEIGHT RANGE KG/12'
1	1112	79.3	57.3	1.9	5.600-5.800

DIE NO 201211

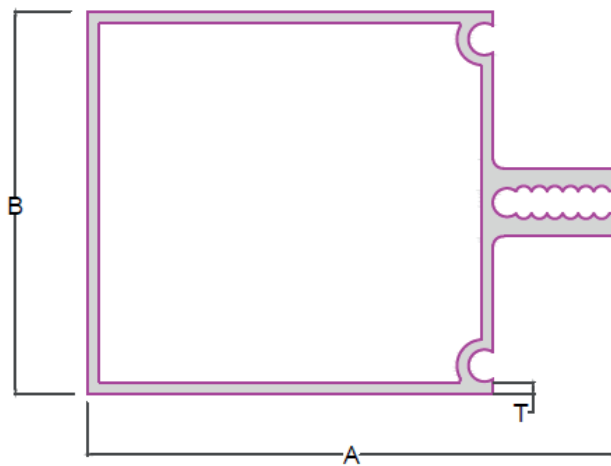

SL NO.	SECTION NO	A	B	T	WEIGHT RANGE KG/12'
1	1113	79.3	57.3	1.84	5.600-6.000

DIE NO 201111

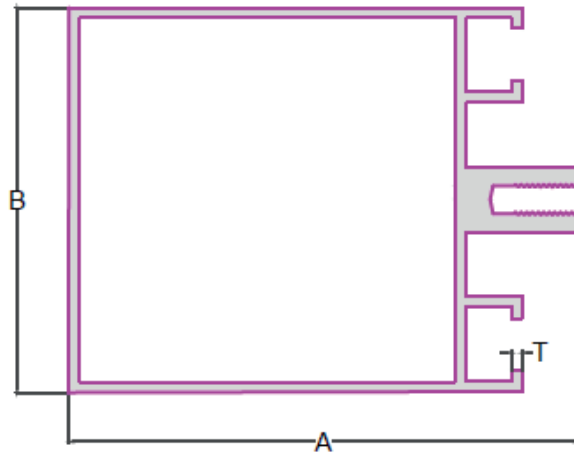

SL NO.	SECTION NO	A	B	T	WEIGHT RANGE KG/12'
1	1114	72.7	55.00	1.54	4.800-5.000

DIE NO A-0911

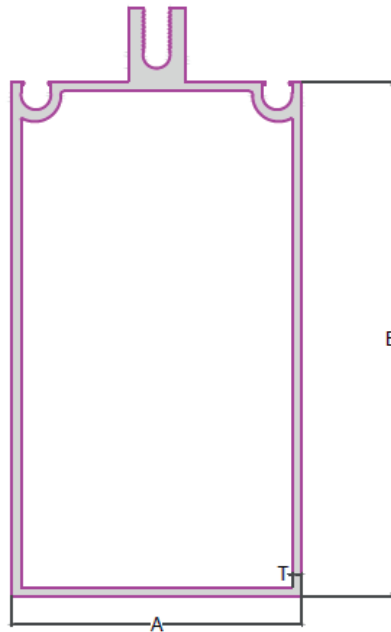

SL NO.	SECTION NO	A	B	T	WEIGHT RANGE KG/12'
1	1115	57.30	115.93	2.00	6.900-7.200

DIE NO A-0912

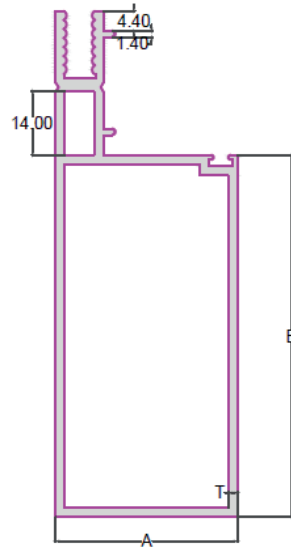

SL NO.	SECTION NO	A	B	T	WEIGHT RANGE KG/12'
1	1116	40.00	111.00	2.00	5.800-6.000

DIE NO A-0918



SL NO.	SECTION NO	A	B	T	WEIGHT RANGE KG/12'
1	1117	55.00	116.00	2.00	7.000-9.000

DIE NO A-0919

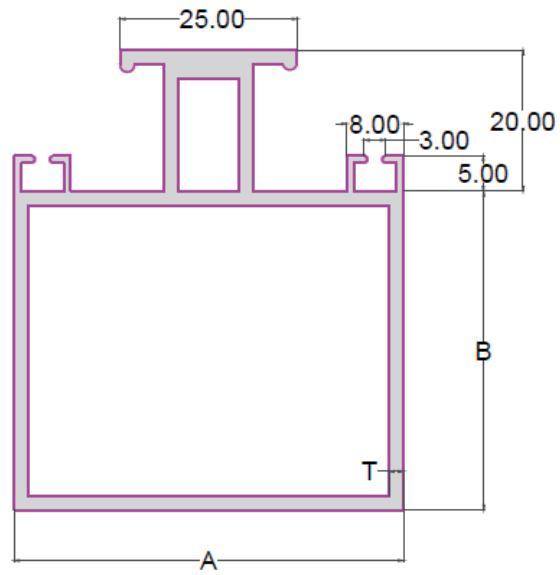

SL NO.	SECTION NO	A	B	T	WEIGHT RANGE KG/12'
1	1118	55.00	65.00	2.00	5.500-5.700

PARTITION SERIES

SINGLE PARTITION

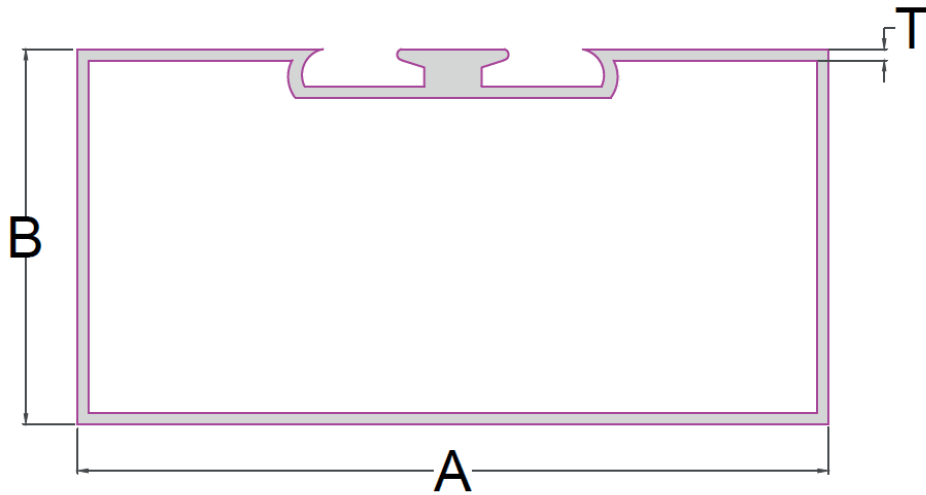

SL NO.	SECTION NO	A	B	T	WEIGHT RANGE KG/12'
1	1119	50.00	25.00	0.90	1.400-1.600
2	1120	60.00	35.00	0.70	1.400-1.500
3	1121	60.00	35.00	1.00	1.800-2.000
4	1122	63.50	38.10	0.81	1.800-2.000
5	1123	63.50	38.10	0.91	2.000-2.200
6	1124	63.50	38.10	1.00	2.200-2.400
7	1125	63.50	38.10	1.12	2.400-2.600
8	1126	63.50	38.10	1.30	2.600-2.800
9	1127	63.50	38.10	1.36	2.900-3.100
10	1128	63.50	38.10	1.89	3.900-4.100
11	1129	63.50	38.10	2.30	4.700-4.900
12	1130	90.00	40.00	1.45	5.700-5.900
13	1131	92.00	24.00	1.09	2.700-2.900
14	1132	100.00	44.00	0.94	4.000-4.200
15	1133	100.00	44.00	1.23	5.300-5.500

DOUBLE PARTITION

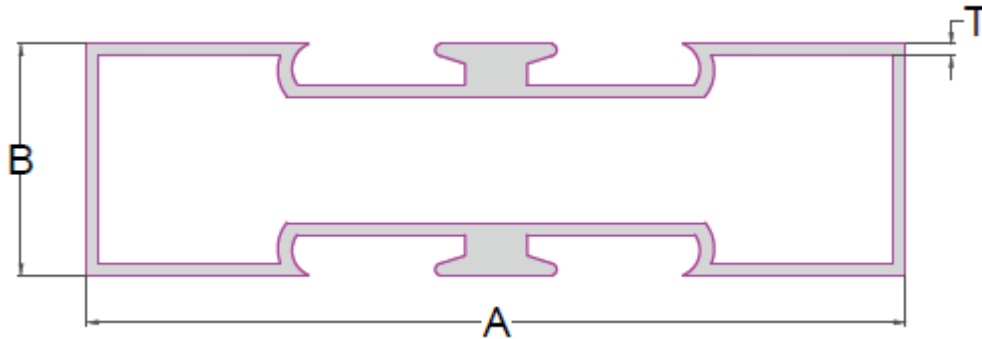

SL NO.	SECTION NO	A	B	T	WEIGHT RANGE KG/12'
1	1134	50.00	25.00	0.65	1.400-1.600
2	1135	60.00	35.00	0.80	1.500-1.600
3	1136	60.00	35.00	0.97	1.800-1.900
4	1137	63.50	38.10	0.75	1.800-2.000
5	1138	63.50	38.10	0.85	2.100-2.300
6	1139	63.50	38.10	0.96	2.300-2.500
7	1140	63.50	38.10	1.06	2.500-2.700
8	1141	63.50	38.10	1.10	2.800-2.900
9	1142	63.50	38.10	1.20	2.900-3.100
10	1143	63.50	38.10	1.65	3.900-4.100
11	1144	92.00	24.00	1.09	2.700-2.900
12	1145	100.00	44.00	0.70	4.000-4.200
13	1146	100.00	44.00	0.95	5.500-5.700

SINGLE LEG PARTITION

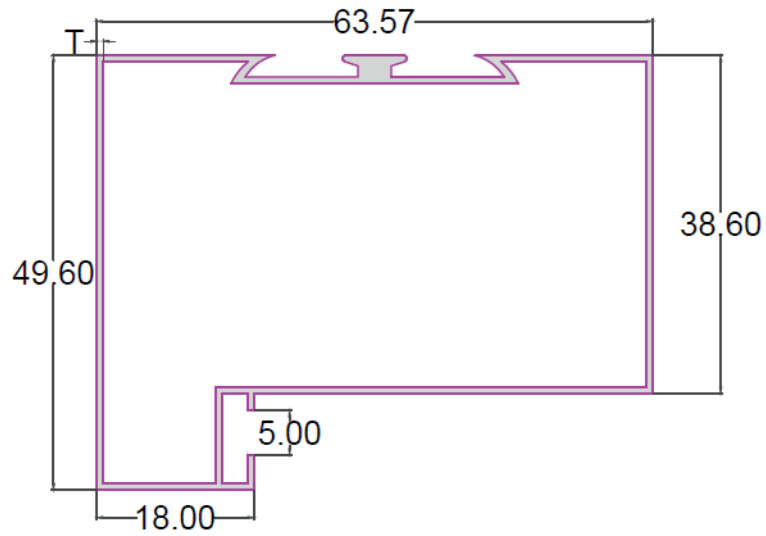

SL NO.	SECTION NO	T	WEIGHT RANGE KG/12'
1	1147	0.73	2.800-2.900
2	1148	1.30	4.100-4.300

2 TRACK SP

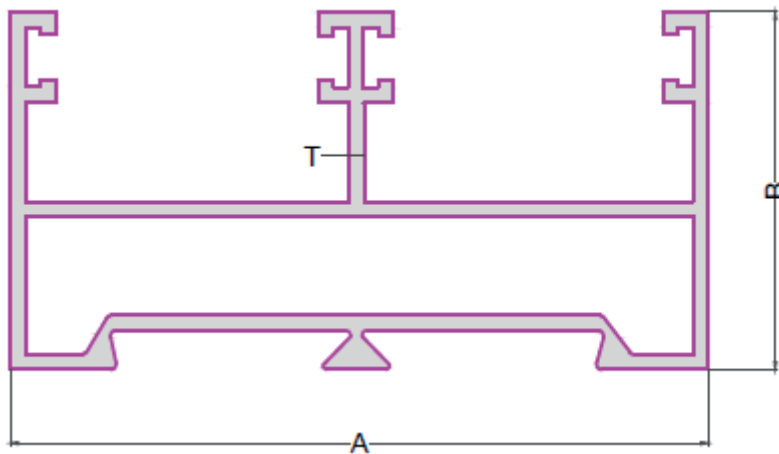

SL NO.	SECTION NO	A	B	T	WEIGHT RANGE KG/12'
1	1149	61.85	31.75	1.35	3.650-4.100

RECTANGLE TUBE SERIES

RECTANGLE TUBE

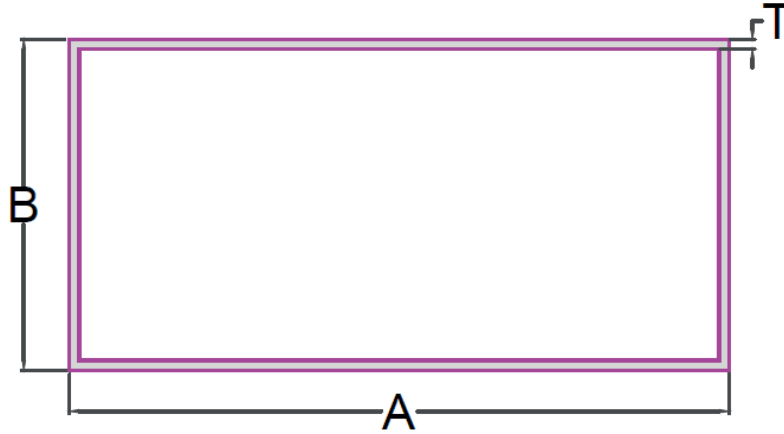

SL NO.	SECTION NO	A	B	T	WEIGHT RANGE KG/12'
1	1150	20.00	10.00	0.71	0.400-0.500
2	1151	20.00	10.00	1.33	0.800-0.900
3	1152	20.00	40.00	1.54	1.800-1.900
4	1153	25.00	12.00	1.16	0.800-0.900
5	1154	25.00	19.00	1.00	0.900-1.000
6	1155	30.00	15.00	2.00	1.800-1.900
7	1156	30.00	20.00	1.10	1.000-1.200
8	1157	35.00	18.00	1.15	1.200-1.300
9	1158	35.00	23.00	0.50	0.600-0.800
10	1159	35.00	23.00	0.73	0.800-0.900
11	1160	35.00	28.00	2.20	2.800-2.900
12	1161	38.00	20.00	1.00	1.100-1.300
13	1162	38.00	25.00	0.63	0.700-0.900
14	1163	38.00	25.00	0.80	0.900-1.100
15	1164	38.00	25.00	0.90	1.100-1.200
16	1165	38.00	25.00	0.95	1.200-1.300
17	1166	38.00	25.00	1.03	1.300-1.400
18	1167	38.00	25.00	1.20	1.500-1.600
19	1168	38.00	25.00	1.34	1.700-1.800
20	1169	38.00	25.00	1.58	1.900-2.100
21	1170	38.00	25.00	1.70	2.100-2.300
22	1171	38.00	25.00	1.98	2.400-2.500

23	1172	38.00	25.00	2.26	2.800-2.900
24	1173	47.00	23.00	0.60	0.800-0.900
25	1174	47.00	23.00	0.78	1.000-1.200
26	1175	48.00	24.00	0.80	1.200-1.300
27	1176	50.00	12.00	1.81	2.200-2.300
28	1177	50.00	18.00	1.17	1.500-1.700
29	1178	50.00	18.00	1.27	1.700-1.900
30	1179	50.00	25.00	0.60	1.000-1.200
31	1180	50.00	25.00	0.80	1.200-1.300
32	1181	50.00	25.00	0.86	1.300-1.400
33	1182	50.00	25.00	0.93	1.400-1.500
34	1183	50.00	25.00	1.00	1.500-1.600
35	1184	50.00	25.00	1.06	1.600-1.700
36	1185	50.00	25.00	1.23	1.800-1.900
37	1186	50.00	25.00	1.33	2.000-2.200
38	1187	50.00	25.00	1.60	2.400-2.500
39	1188	50.00	25.00	1.80	2.700-2.900
40	1189	50.00	25.00	2.20	3.200-3.500
41	1190	50.00	25.00	2.83	4.200-4.300
42	1191	50.00	38.00	1.10	1.900-2.000
43	1192	50.00	38.00	1.64	2.800-3.000
44	1193	50.00	38.00	2.10	3.700-3.800
45	1194	50.00	38.00	2.43	4.200-4.300
46	1195	50.00	38.00	3.49	6.000-6.200
47	1196	63.00	25.00	0.73	1.300-1.500
48	1197	63.00	25.00	0.88	1.500-1.600
49	1198	63.00	25.00	0.96	1.600-1.700
50	1199	63.00	25.00	1.09	1.800-2.000
51	1200	63.00	25.00	1.25	2.000-2.200
52	1201	63.00	25.00	1.78	3.000-3.200
53	1202	63.00	38.00	0.76	1.500-1.600
54	1203	63.00	38.00	1.03	2.000-2.200
55	1204	63.00	38.00	1.18	2.200-2.500
56	1205	63.00	38.00	1.40	2.800-3.000
57	1206	63.00	38.00	1.60	3.200-3.300
58	1207	63.00	38.00	1.98	4.000-4.200
59	1208	63.00	38.00	2.47	5.000-5.200
60	1209	63.00	38.00	3.00	6.000-6.200
61	1210	75.00	12.00	1.18	2.000-2.100



62	1211	75.00	12.00	1.69	2.900-3.000
63	1212	75.00	19.00	1.30	2.400-2.500
64	1213	75.00	19.00	1.75	3.200-3.300
65	1214	75.00	25.00	0.85	1.600-1.800
66	1215	75.00	25.00	1.40	2.800-2.900
67	1216	75.00	25.00	1.87	3.500-3.900
68	1217	75.00	25.00	2.07	4.000-4.200
69	1218	75.00	25.00	2.20	4.400-4.500
70	1219	75.00	38.00	1.50	3.400-3.500
71	1220	75.00	30.00	1.71	3.500-3.800
72	1221	75.00	38.00	1.90	4.200-4.300
73	1222	75.00	60.00	1.54	4.000-4.200
74	1223	80.00	15.00	0.89	1.700-1.800
75	1224	92.00	24.00	1.00	2.200-2.300
76	1225	92.00	24.00	1.19	2.700-2.800
77	1226	92.00	24.00	1.37	3.000-3.300
78	1227	100.00	12.00	1.38	3.000-3.200
79	1228	100.00	19.00	1.47	3.500-3.700
80	1229	100.00	38.00	2.00	5.500-5.600
81	1230	100.00	42.00	1.25	3.500-3.600
82	1231	100.00	50.00	1.50	4.500-4.600
83	1232	100.00	50.00	2.88	8.600-8.700
84	1233	125.00	25.00	1.23	3.500-4.000
85	1234	125.00	25.00	1.50	4.400-4.700
86	1235	125.00	25.00	1.93	5.800-6.000
87	1236	127.00	25.00	1.74	5.300-5.500



SQUARE TUBE SERIES

SQUARE TUBE

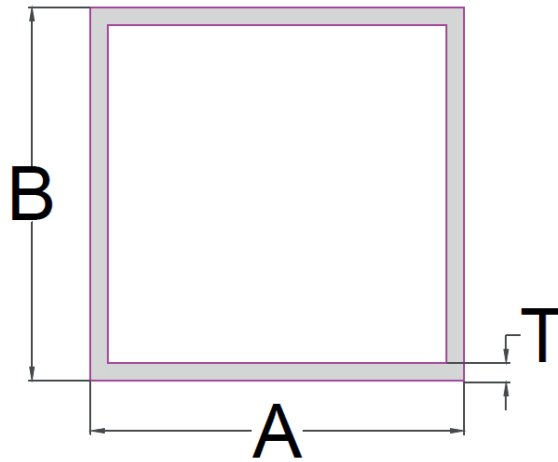

SL NO.	SECTION NO	A	B	T	WEIGHT RANGE KG/12'
1	1237	16.00	16.00	0.60	0.300-0.500
2	1238	22.00	22.00	0.50	0.400-0.600
3	1239	22.00	22.00	1.00	0.800-0.900
4	1240	22.00	22.00	1.56	1.300-1.400
5	1241	25.00	25.00	1.40	1.400-1.500
6	1242	32.00	32.00	0.75	0.850-1.100
7	1243	32.00	32.00	1.40	1.800-1.900
8	1244	38.00	38.00	1.25	1.900-2.100
9	1245	38.00	38.00	1.74	2.600-2.700
10	1246	38.00	38.00	2.23	3.300-3.500
11	1247	45.00	45.00	1.44	2.500-2.700
12	1248	50.00	50.00	0.90	1.800-2.000
13	1249	50.00	50.00	1.25	2.400-2.600
14	1250	50.00	50.00	1.55	3.000-3.200
15	1251	50.00	50.00	1.85	3.600-3.800
16	1252	50.00	50.00	2.10	4.100-4.300
17	1253	50.00	50.00	2.50	5.000-5.200
18	1254	61.00	61.00	3.20	7.700-7.900
19	1255	75.00	75.00	1.80	5.200-5.400

20 MM SERIES

20 MM HANDLE

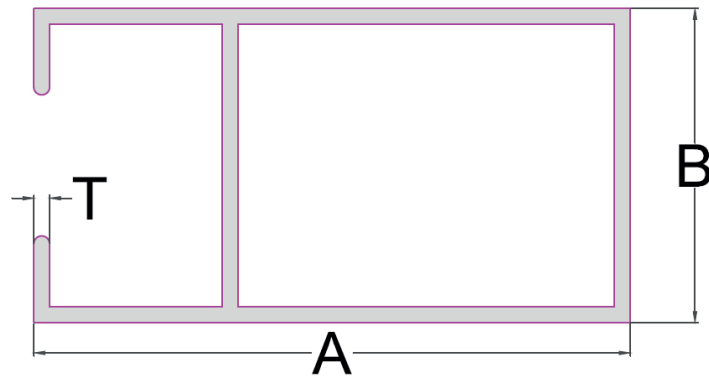

SL NO.	SECTION NO	A	B	T	WEIGHT RANGE KG/12'
1	1256	38.00	20.00	0.67	0.900-1.000
2	1257	38.00	20.00	0.90	1.200-1.400

20 MM INTERLOCK

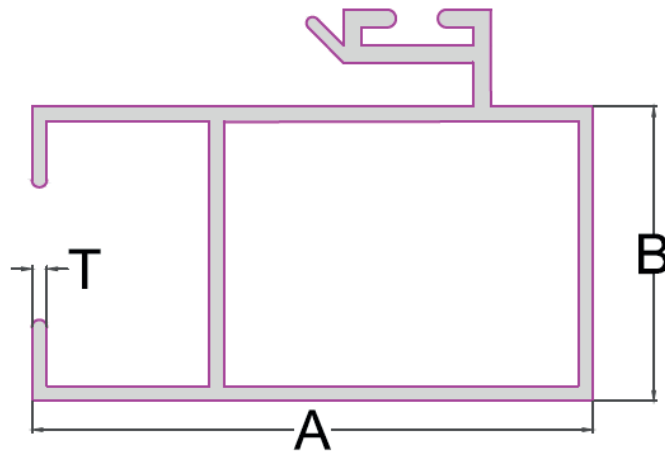

SL NO.	SECTION NO	A	B	T	WEIGHT RANGE KG/12'
1	1258	38.00	20.00	1.33	1.800-1.900

20 MM TOP BOTTOM

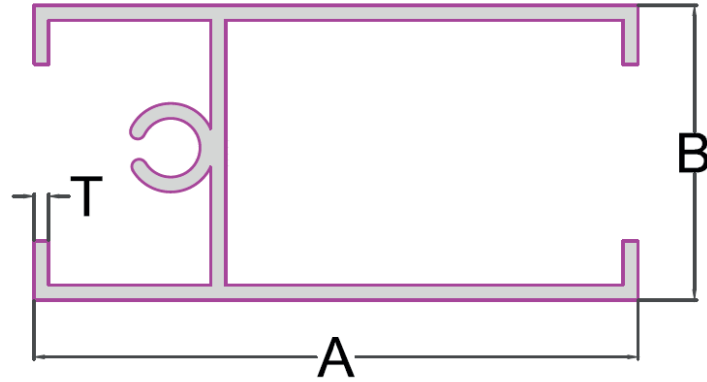

SL NO.	SECTION NO	A	B	T	WEIGHT RANGE KG/12'
1	1259	41.00	20.00	1.11	1.600-1.800

20 MM HANDLE 2

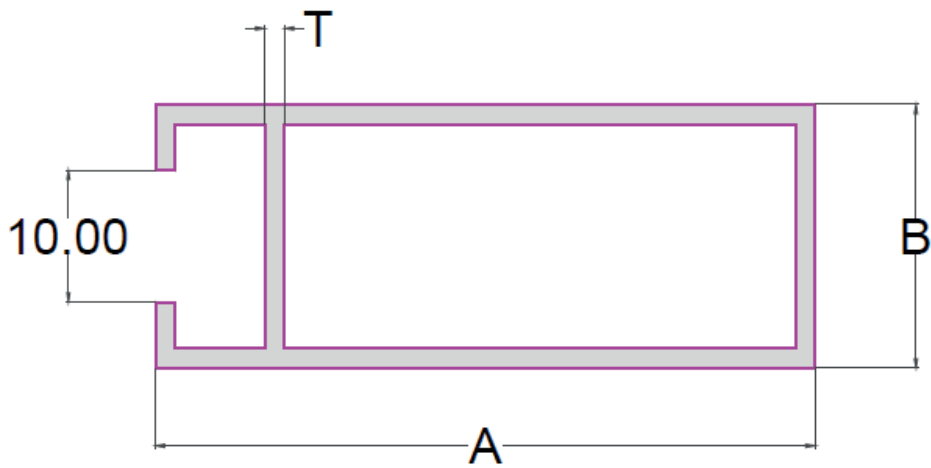

SL NO.	SECTION NO	A	B	T	WEIGHT RANGE KG/12'
1	1260	50.00	20.00	1.50	1.300-1.500

20 MM-2 TRACK TOP

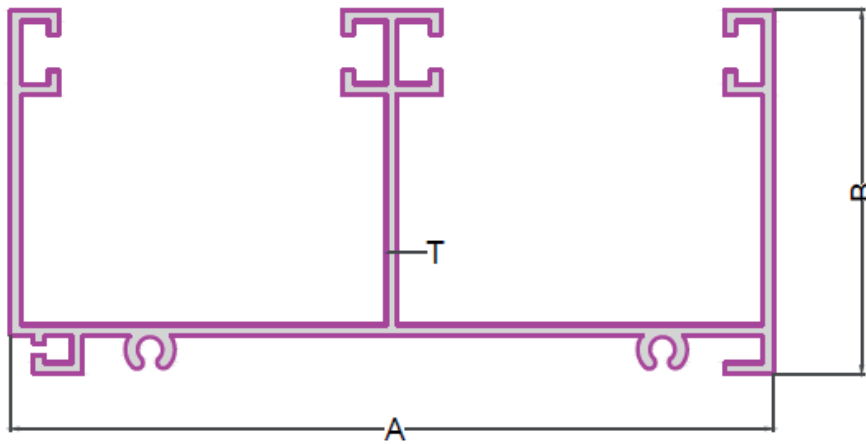

SL NO.	SECTION NO	A	B	T	WEIGHT RANGE KG/12'
1	1261	62.00	29.50	0.90	1.800-2.100
2	1262	62.00	29.50	1.17	2.400-2.600

20 MM-2 TRACK BOTTOM

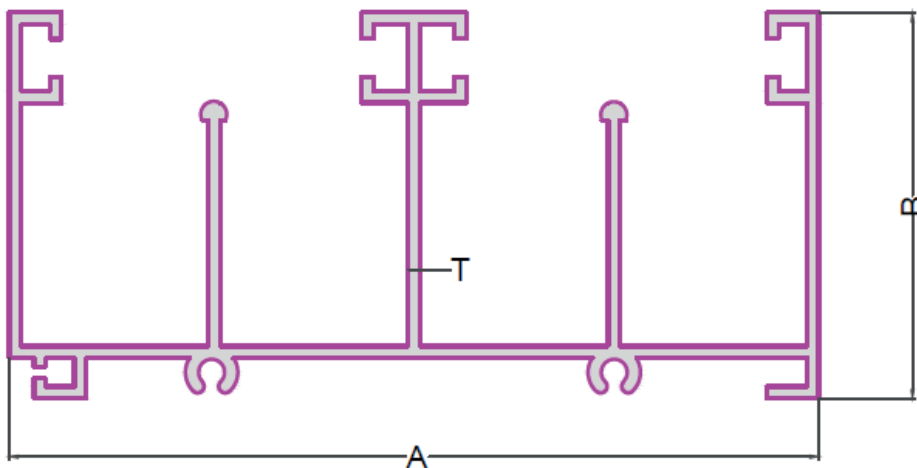

SL NO.	SECTION NO	A	B	T	WEIGHT RANGE KG/12'
1	1263	62.00	29.50	0.80	1.900-2.100
2	1264	62.00	29.50	0.90	2.200-2.400

20 MM-3 TRACK TOP

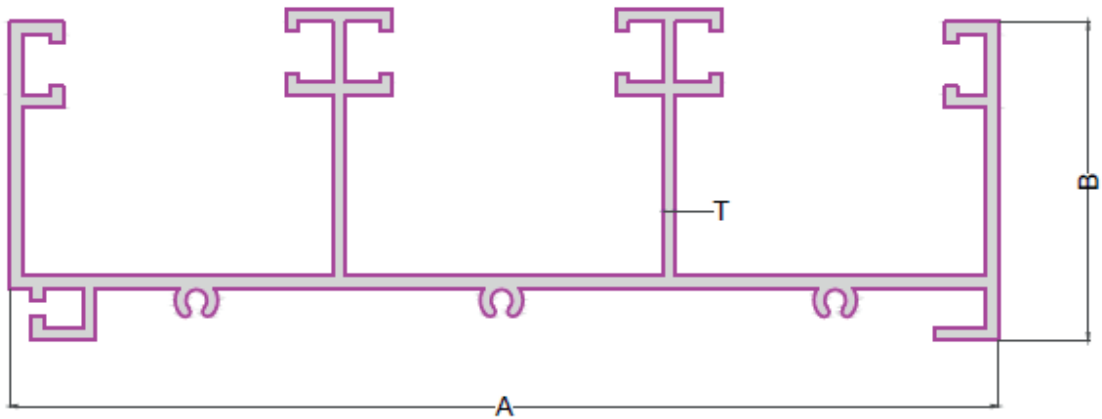

SL NO.	SECTION NO	A	B	T	WEIGHT RANGE KG/12'
1	1265	92.36	29.70	1.10	2.800-3.000
2	1266	92.36	29.70	1.15	3.200-3.400

20 MM-3 TRACK BOTTOM

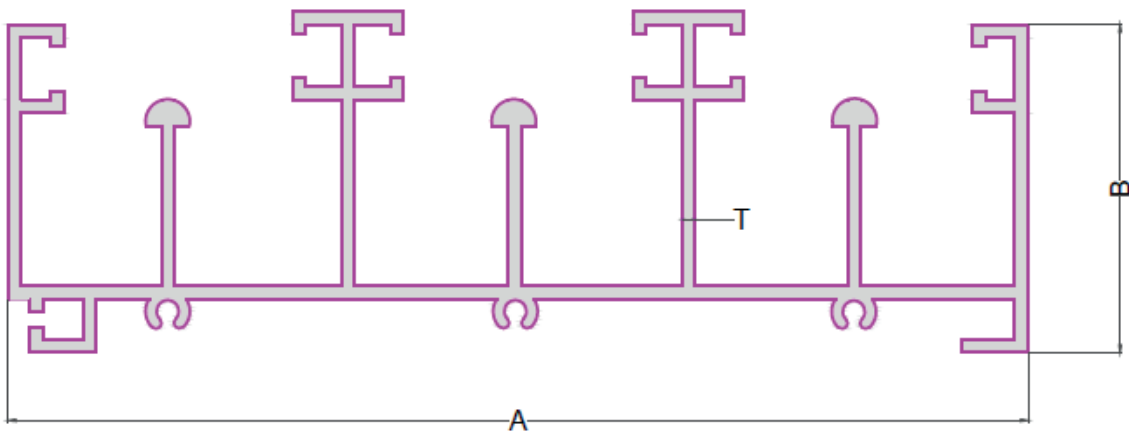

SL NO.	SECTION NO	A	B	T	WEIGHT RANGE KG/12'
1	1267	92.36	29.70	1.40	3.300-3.500

12 MM SERIES

12 MM INTERLOCK

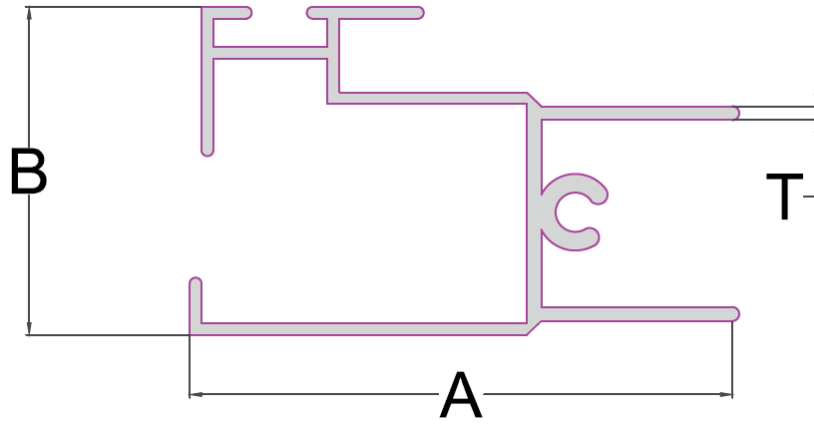

SL NO.	SECTION NO	A	B	T	WEIGHT RANGE KG/12'
1	1268	32.00	19.33	1.00	0.900-1.200

12 MM TOP BOTTOM

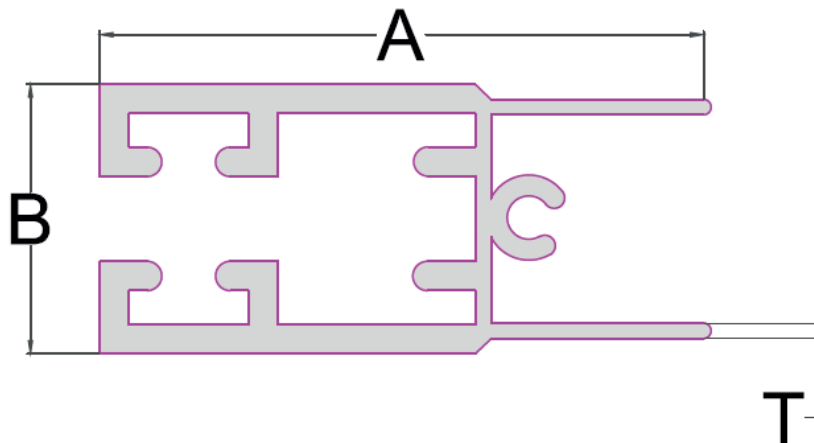

SL NO.	SECTION NO	A	B	T	WEIGHT RANGE KG/12'
1	1269	32.00	14.3	1.10	0.900-1.000

25 MM SERIES

25 MM HANDLE

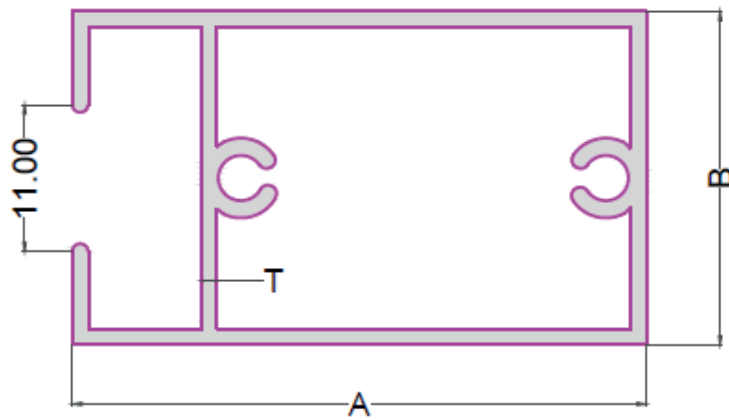

SL NO.	SECTION NO	A	B	T	WEIGHT RANGE KG/12'
1	1270	50.00	25.00	1.70	2.600-2.800

25 MM INTERLOCK

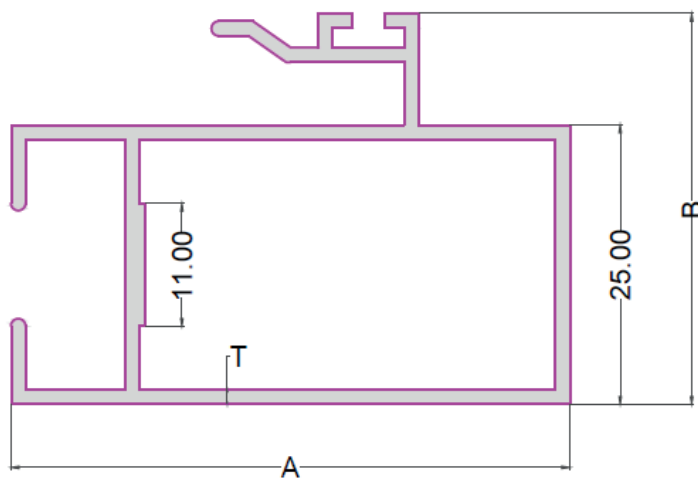

SL NO.	SECTION NO	A	B	T	WEIGHT RANGE KG/12'
1	1271	50.00	35.00	1.30	3.300-3.500

25 MM BEARING BOTTOM

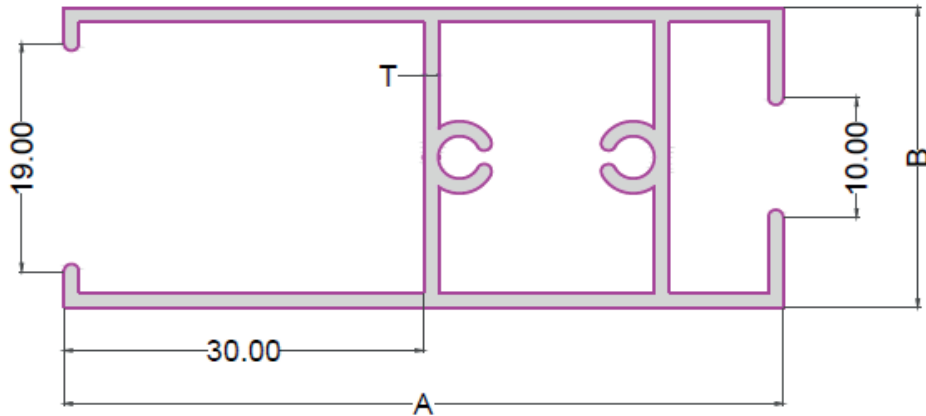

SL NO.	SECTION NO	A	B	T	WEIGHT RANGE KG/12'
1	1272	60.00	25.00	1.25	2.800-3.000

25 MM-2 TRACK TOP

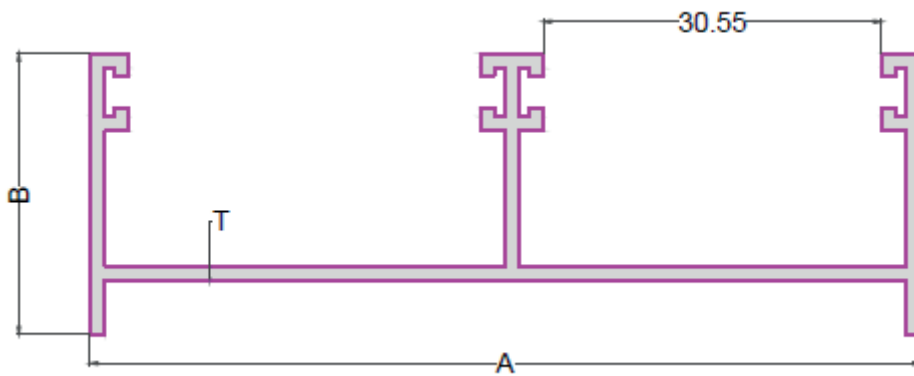

SL NO.	SECTION NO	A	B	T	WEIGHT RANGE KG/12'
1	1273	75.00	25.40	1.30	3.000-3.200

25 MM-2 TRACK BOTTOM

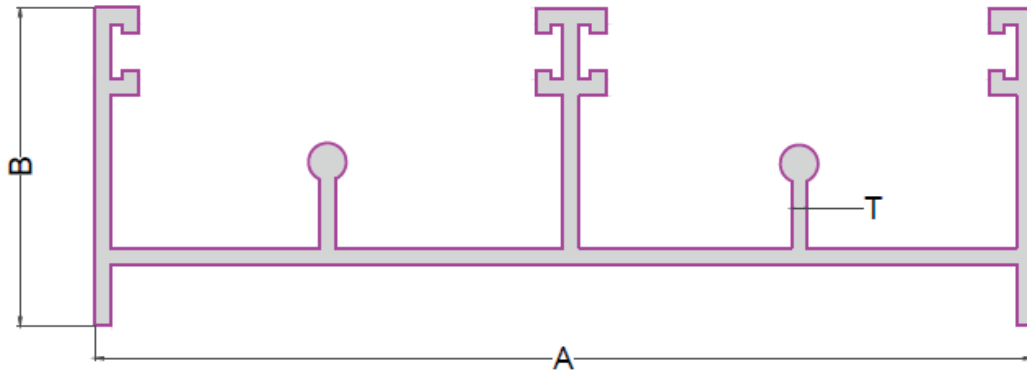

SL NO.	SECTION NO	A	B	T	WEIGHT RANGE KG/12'
1	1274	75.00	25.40	1.25	4.600-4.800

1.7 MM THICK 25 MM HANDLE

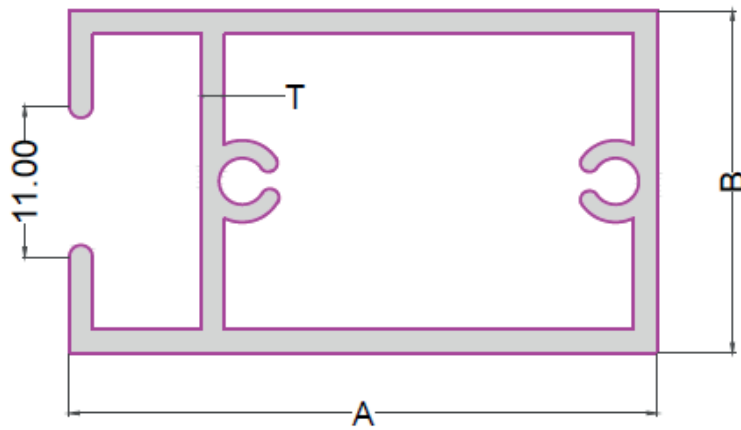

SL NO.	SECTION NO	A	B	T	WEIGHT RANGE KG/12'
1	1275	43.00	25.00	1.70	2.450-2.600

1.7 MM THICK 25 MM INTERLOCK

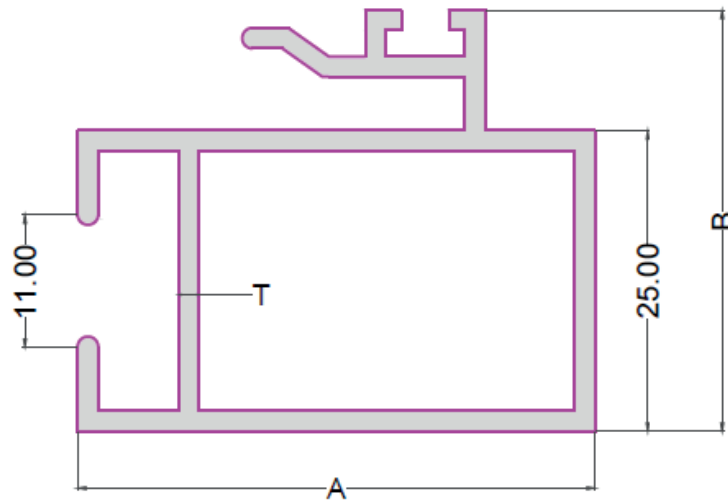

SL NO.	SECTION NO	A	B	T	WEIGHT RANGE KG/12'
1	1276	43.00	25.00	1.70	2.500-2.750

60 X 25 BEARING BOTTOM

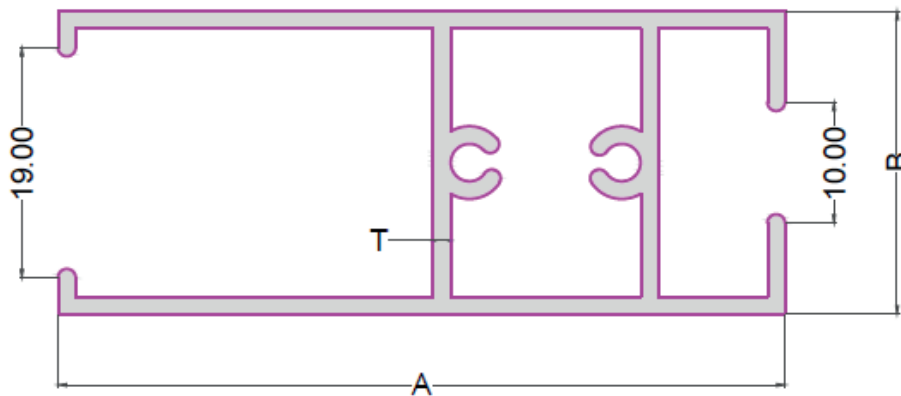

SL NO.	SECTION NO	A	B	T	WEIGHT RANGE KG/12'
1	1277	60.00	25.00	1.45	2.000-2.200
2	1278	60.00	25.00	1.70	2.800-3.000

HANDLE SERIES

20 X 50 HANDLE

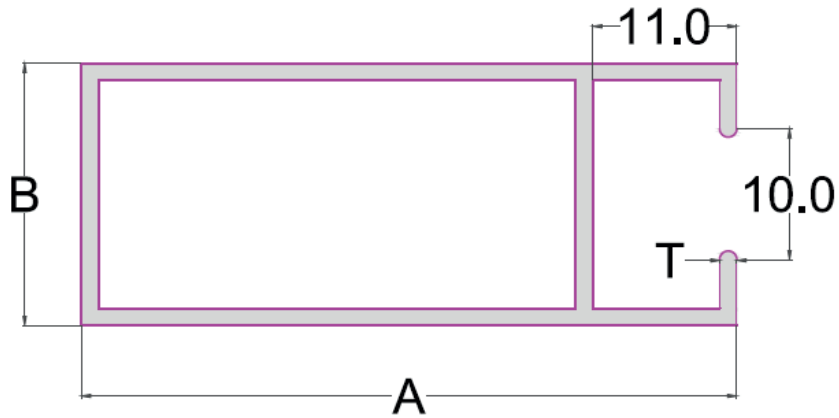

SL NO.	SECTION NO	A	B	T	WEIGHT RANGE KG/12'
1	1279	50.00	20.00	0.85	1.000-1.200

43 X 25 HANDLE

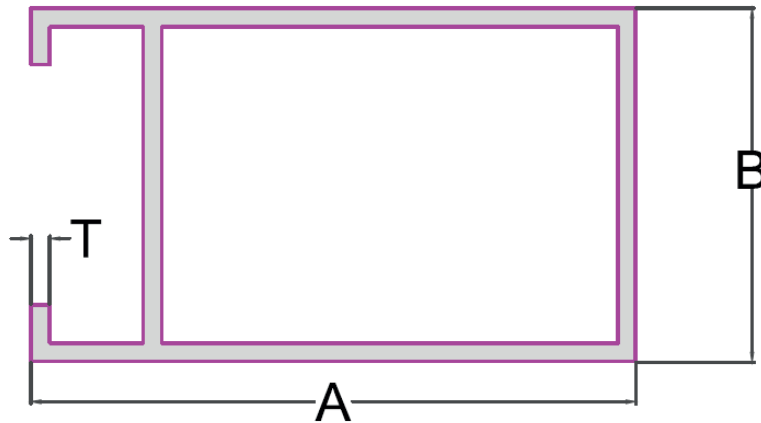

SL NO.	SECTION NO	A	B	T	WEIGHT RANGE KG/12'
1	1280	43.00	25.00	1.70	2.400-2.600

43 X 25 INTERLOCK

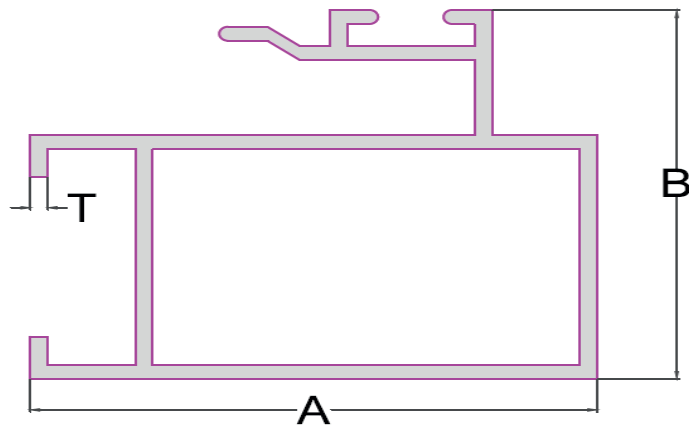

SL NO.	SECTION NO	A	B	T	WEIGHT RANGE KG/12'
1	1281	42.8	35.1	1.33	2.500-2.600

1302 HANDLE

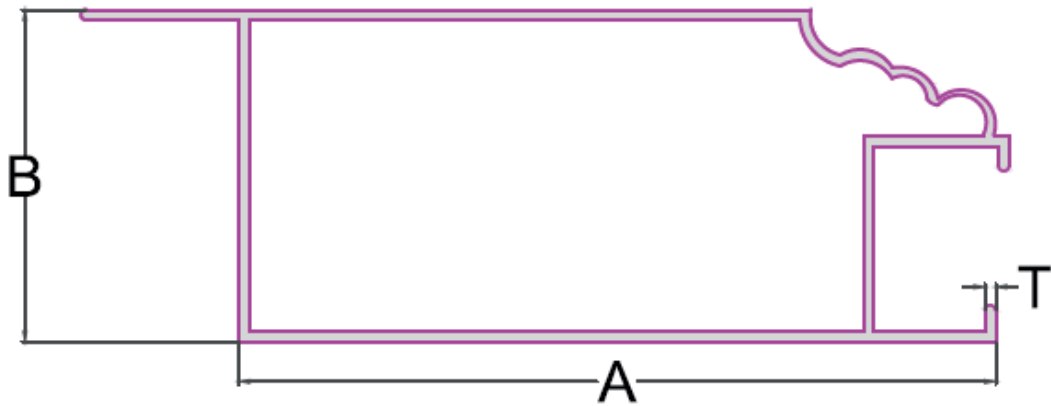

SL NO.	SECTION NO	A	B	T	WEIGHT RANGE KG/12'
1	1282	49.5	21	0.89	1.200-1.300

1303 HANDLE WITH LEG

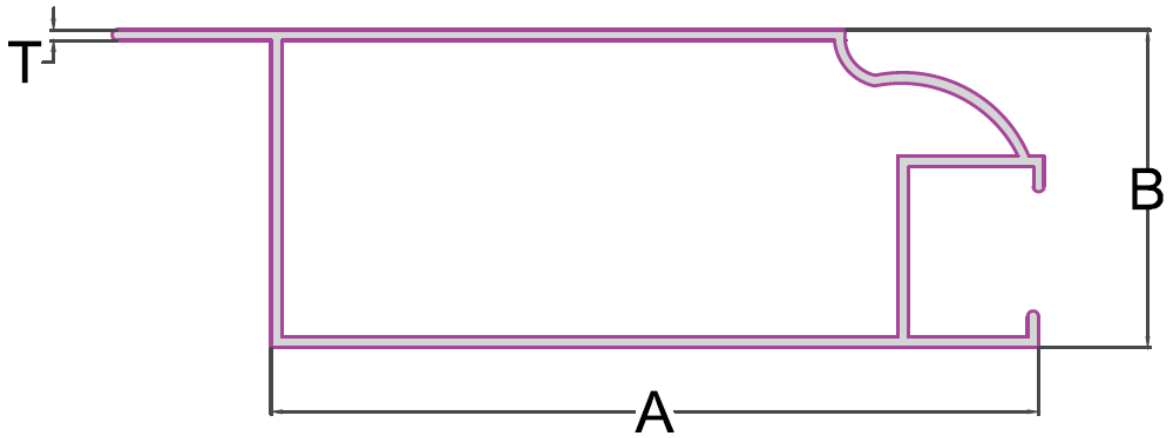

SL NO.	SECTION NO	A	B	T	WEIGHT RANGE KG/12'
1	1283	50	20.7	1.00	1.300-1.400

20758 HANDLE

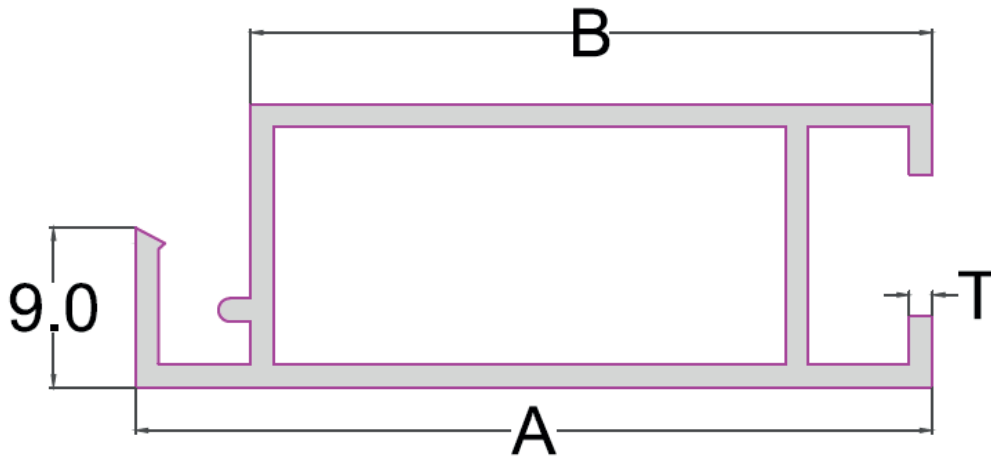

SL NO.	SECTION NO	A	B	T	WEIGHT RANGE KG/12'
1	1284	38.00	25.40	1.30	1.500-1.700

43 X 25 HANDLE

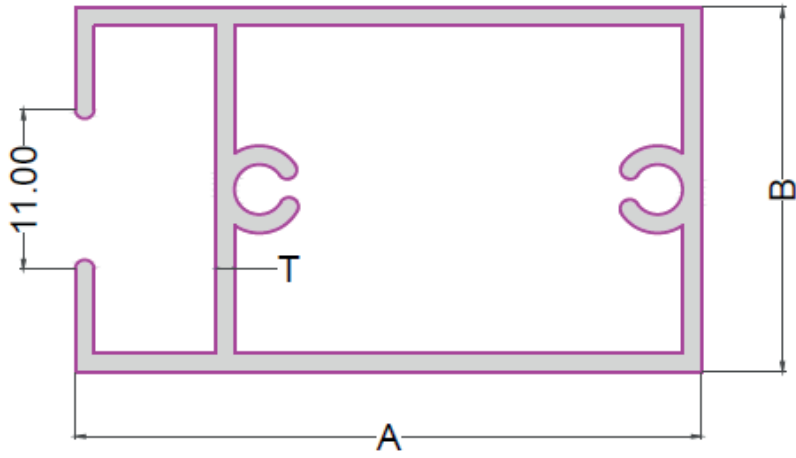

SL NO.	SECTION NO	A	B	T	WEIGHT RANGE KG/12'
1	1285	43.00	25.00	1.30	2.450-2.600

TAPPER SERIES

TAPPER HANDLE

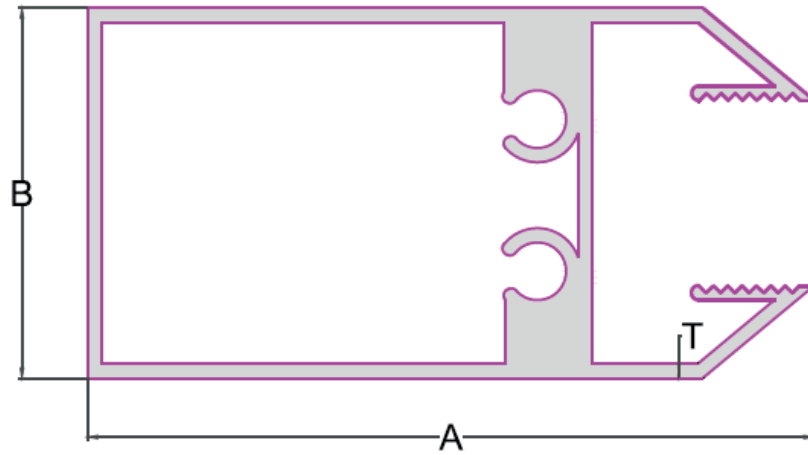

SL NO.	SECTION NO	A	B	T	WEIGHT RANGE KG/12'
1	1286	50.60	25.70	1.70	2.300-2.500

TAPPER GLASS MEETING

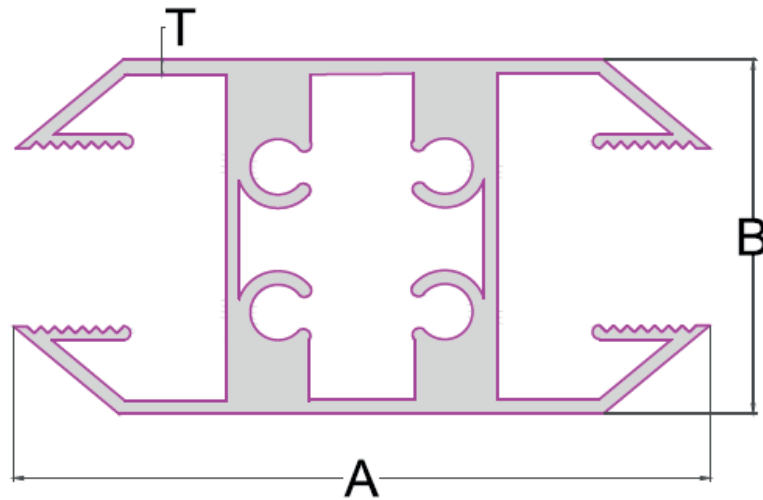

SL NO.	SECTION NO	A	B	T	WEIGHT RANGE KG/12'
1	1287	50.8	25.4	1.70	3.000-3.200

'U' CHANNEL SERIES

U CHANNEL

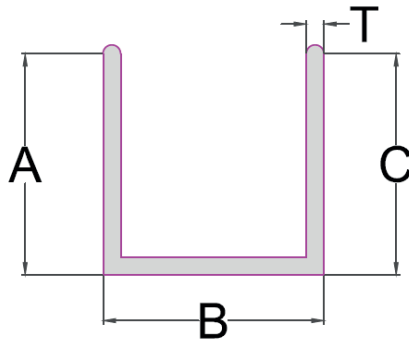

SL NO.	SECTION NO	A	B	C	T	WEIGHT RANGE KG/12'
1	1288	9.50	9.50	9.50	0.95	0.200-0.300
2	1289	12.00	12.00	12.00	1.10	0.300-0.450
3	1290	16.00	16.00	16.00	1.41	0.600-0.700
4	1291	25.00	19.00	25.00	1.33	0.900-1.000
5	1292	25.00	25.00	25.00	2.80	2.000-2.200
6	1293	38.00	25.00	38.00	1.45	1.400-1.500
7	1294	70.00	30.00	70.00	3.23	5.400-5.600
8	1295	75.00	75.00	75.00	1.90	4.200-4.300

CLASSIC U CHANNEL

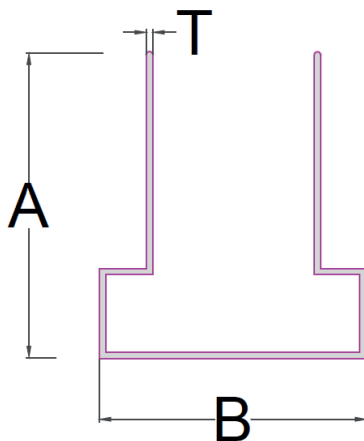

SL NO.	SECTION NO	A	B	T	WEIGHT RANGE KG/12'
1	1296	18.50	16.30	0.50	0.300-0.500

‘C’ CHANNEL SERIES

C CHANNEL

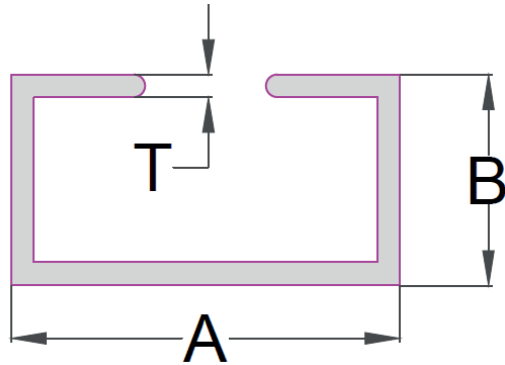

SL NO.	SECTION NO	A	B	T	WEIGHT RANGE KG/12'
1	1297	22.00	12.00	0.70	0.400-0.500
2	1298	22.00	12.00	1.00	0.550-0.650
3	1299	25.00	25.00	0.78	0.650-0.750
4	1300	36.00	16.00	1.04	0.800-0.900
5	1301	38.00	25.00	1.56	1.550-1.650
6	1302	38.00	38.00	1.32	1.650-1.750
7	1303	50.00	19.00	1.13	1.100-1.200
8	1304	50.00	25.00	1.07	1.200-1.300
9	1305	50.00	25.00	1.78	2.000-2.100
10	1306	50.00	50.00	1.67	2.700-2.800

WIRING C CHANNEL

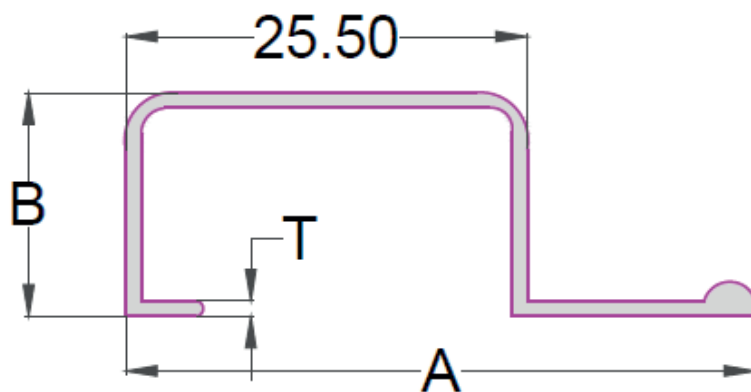

SL NO.	SECTION NO	A	B	T	WEIGHT RANGE KG/12'
1	1307	40.00	14.20	0.65	0.300-0.500
2	1308	40.00	14.20	0.98	0.700-0.900

BULB C CHANNEL

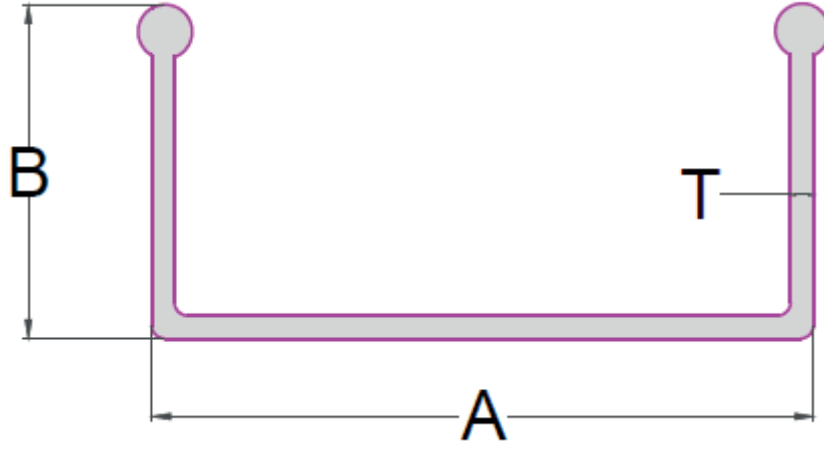

SL NO.	SECTION NO	A	B	T	WEIGHT RANGE KG/12'
1	1309	25.00	12.00	0.85	0.400-0.600

ANGLE SERIES

L ANGLE

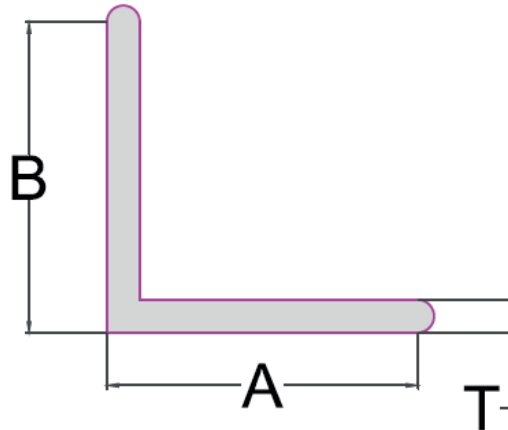

SL NO.	SECTION NO	A	B	T	WEIGHT RANGE KG/12'
1	1310	12.00	12.00	1.16	0.250-0.350
2	1311	18.00	12.00	1.63	0.450-0.550
3	1312	18.00	18.00	1.44	0.500-0.600
4	1313	18.00	18.00	1.80	0.600-0.700
5	1314	18.00	18.00	2.66	0.800-1.000
6	1315	25.00	25.00	0.90	0.400-0.500
7	1316	25.00	25.00	1.76	0.800-0.900
8	1317	25.00	25.00	2.30	1.000-1.200
9	1318	25.00	25.00	2.80	1.350-1.450
10	1319	32.00	32.00	2.80	1.750-1.850
11	1320	38.00	19.00	2.45	1.350-1.450
12	1321	38.00	25.00	1.74	1.000-1.200
13	1322	38.00	25.00	2.38	1.450-1.550
14	1323	38.00	25.00	2.93	1.800-1.900
15	1324	38.00	38.00	3.00	2.200-2.400
16	1325	38.00	38.00	4.60	3.450-3.550
17	1326	50.00	25.00	3.00	2.200-2.400
18	1327	50.00	50.00	2.90	2.800-3.100
19	1328	50.00	50.00	4.50	4.450-4.600
20	1329	50.00	50.00	5.60	5.500-5.700
21	1330	75.00	25.00	2.00	1.900-2.100
22	1331	75.00	38.00	2.65	2.900-3.100
23	1332	75.00	75.00	2.63	3.900-4.100

34 CLIT ANGLE

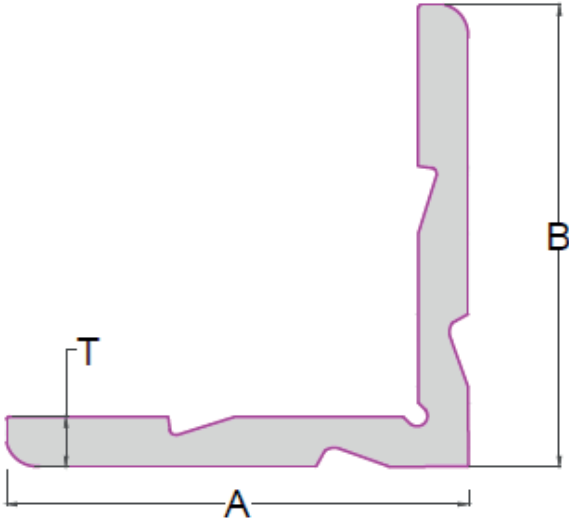

SL NO.	SECTION NO	A	B	T	WEIGHT RANGE KG/12'
1	1333	44.5	44.5	4.80	3.600-3.700



KITCHEN SERIES

ROUND KITCHEN

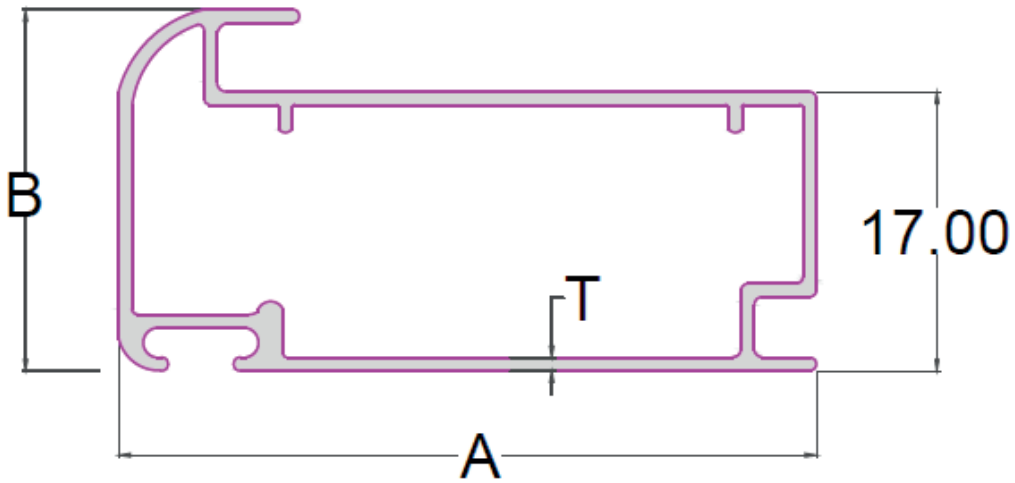

SL NO.	SECTION NO	A	B	T	WEIGHT RANGE KG/12'
1	1334	42.50	22.00	0.80	1.100-1.200

J SQUARE KITCHEN

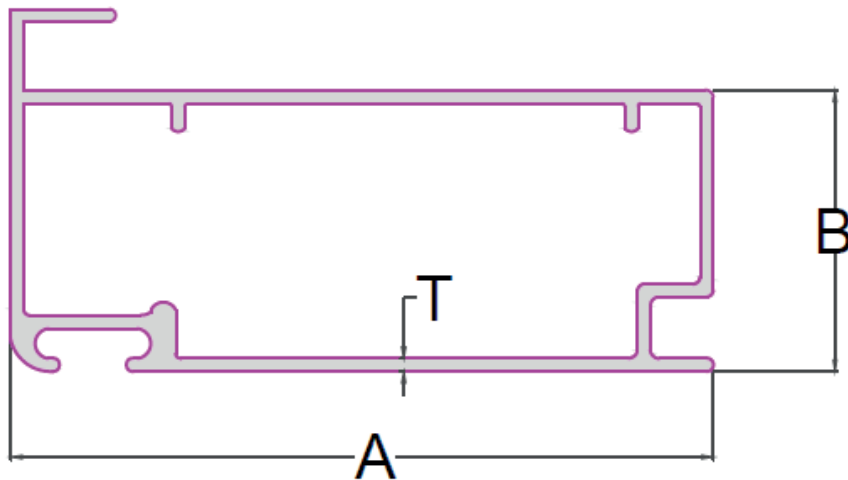

SL NO.	SECTION NO	A	B	T	WEIGHT RANGE KG/12'
1	1335	42.50	21.90	0.80	1.000-1.200

D KITCHEN CABINET

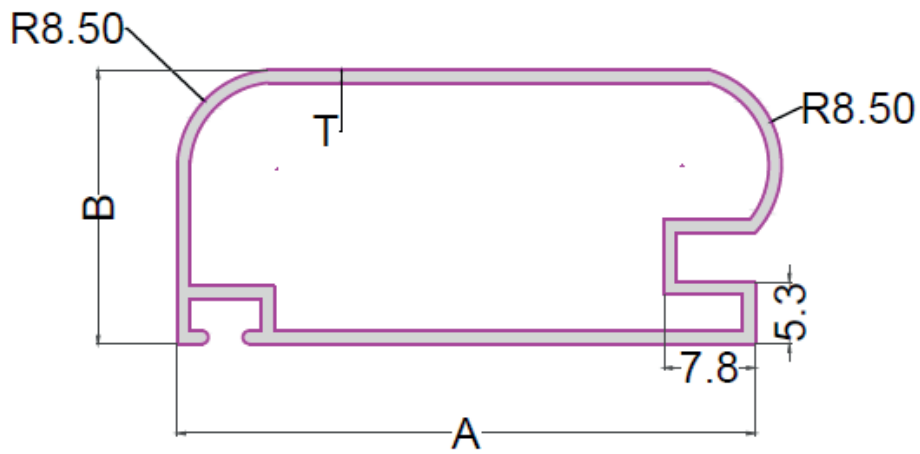

SL NO.	SECTION NO	A	B	T	WEIGHT RANGE KG/12'
1	1336	49.4	23.4	1.10	1.100-1.300

SQUARE KITCHEN WITH HANDLE

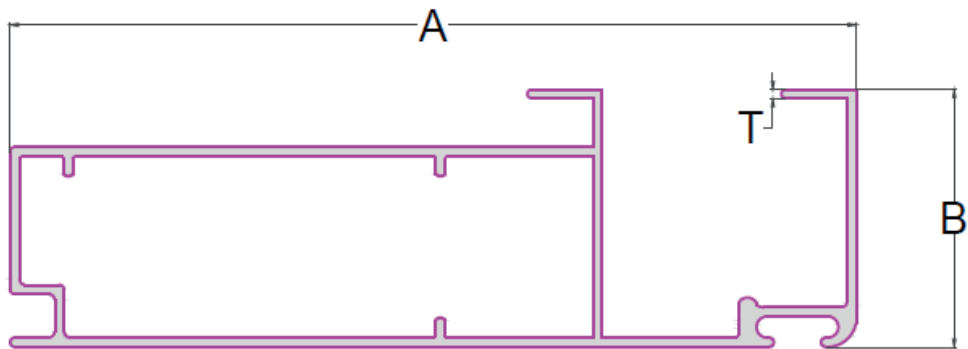

SL NO.	SECTION NO	A	B	T	WEIGHT RANGE KG/12'
1	1337	72.00	21.50	0.75	0.800-1.000

K-1901

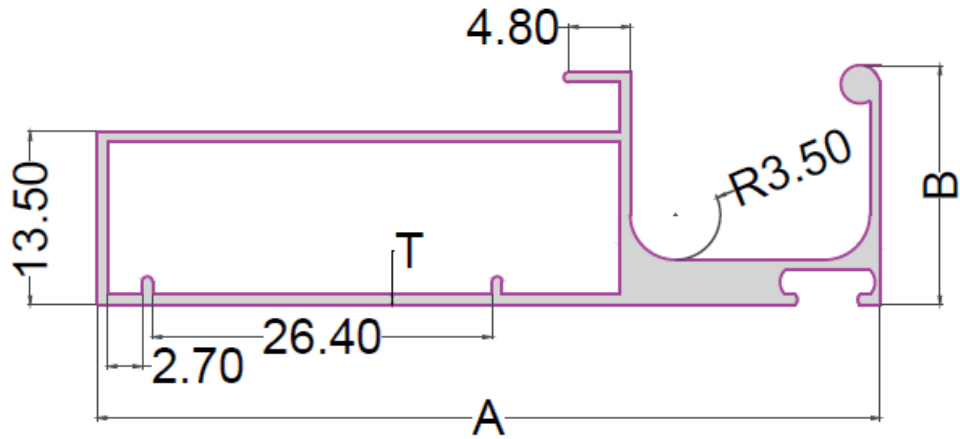

SL NO.	SECTION NO	A	B	T	WEIGHT RANGE KG/12'
1	1338	60.90	18.60	0.80	1.900-2.200

K-1902

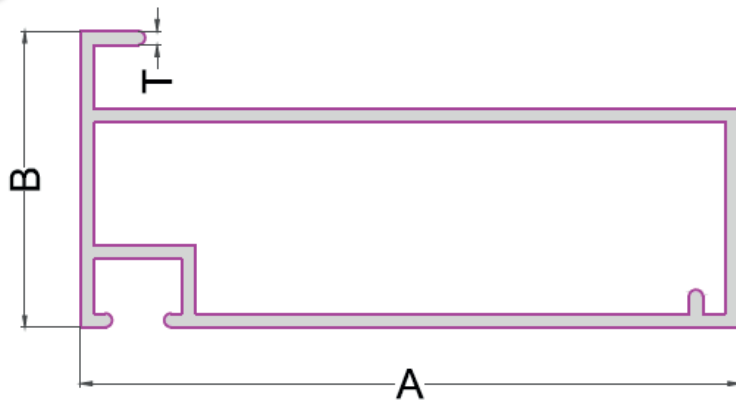

SL NO.	SECTION NO	A	B	T	WEIGHT RANGE KG/12'
1	1339	40.00	18.00	0.85	1.000-1.200

H-2007

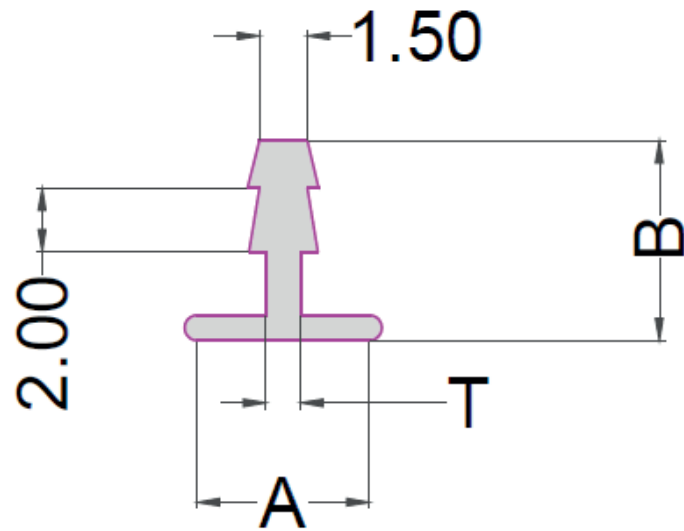

SL NO.	SECTION NO	A	B	T	WEIGHT RANGE KG/12'
1	1340	5.40	6.30	1.10	0.200-0.400

H-2008

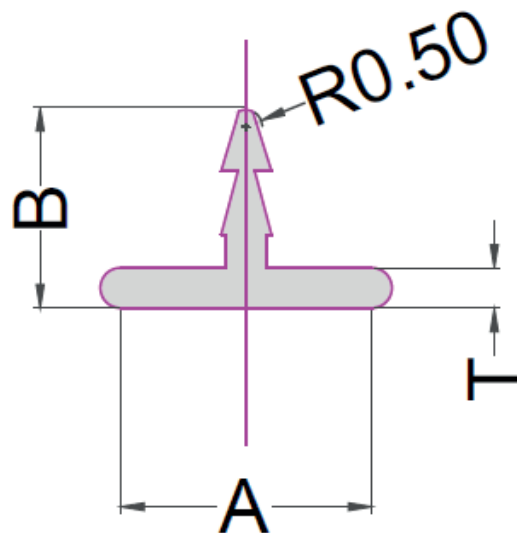

SL NO.	SECTION NO	A	B	T	WEIGHT RANGE KG/12'
1	1341	7.50	6.00	1.20	0.100-0.300

H-2009

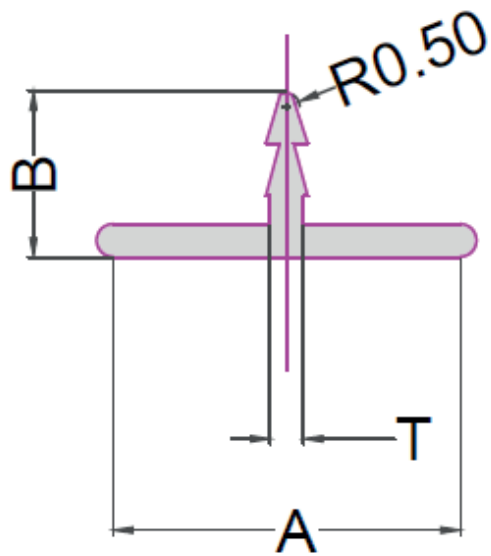

SL NO.	SECTION NO	A	B	T	WEIGHT RANGE KG/12'
1	1342	12.50	6.00	1.20	0.200-0.400

H-2010

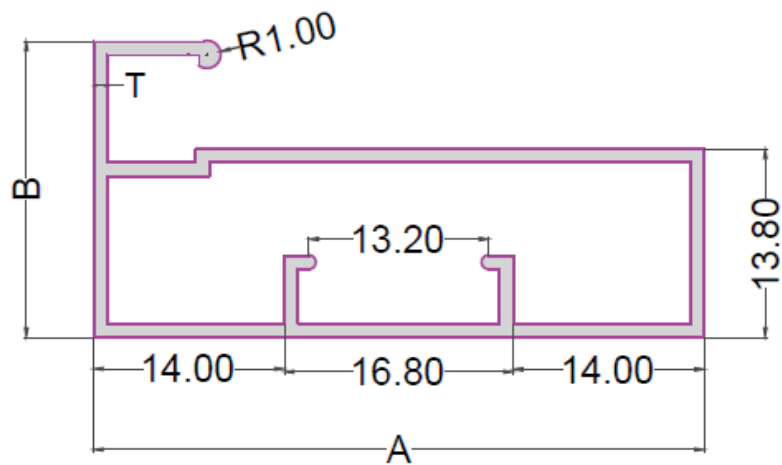

SL NO.	SECTION NO	A	B	T	WEIGHT RANGE KG/12'
1	1343	44.80	21.70	1.00	1.300-1.500

H-2011

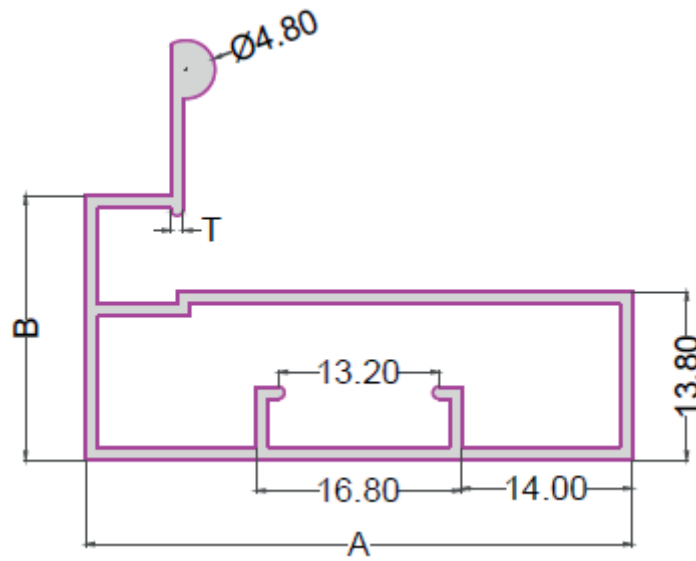

SL NO.	SECTION NO	A	B	T	WEIGHT RANGE KG/12'
1	1344	44.80	21.70	1.25	2.000-2.200

H-2012

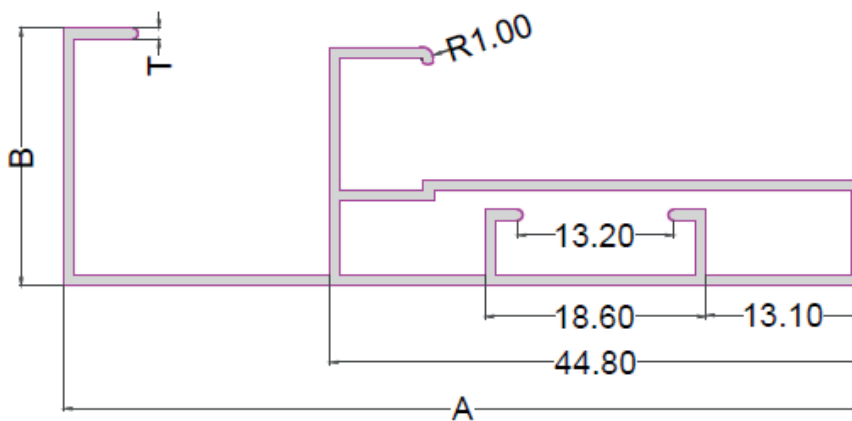

SL NO.	SECTION NO	A	B	T	WEIGHT RANGE KG/12'
1	1345	67.20	21.70	0.90	1.600-1.800

H-2013

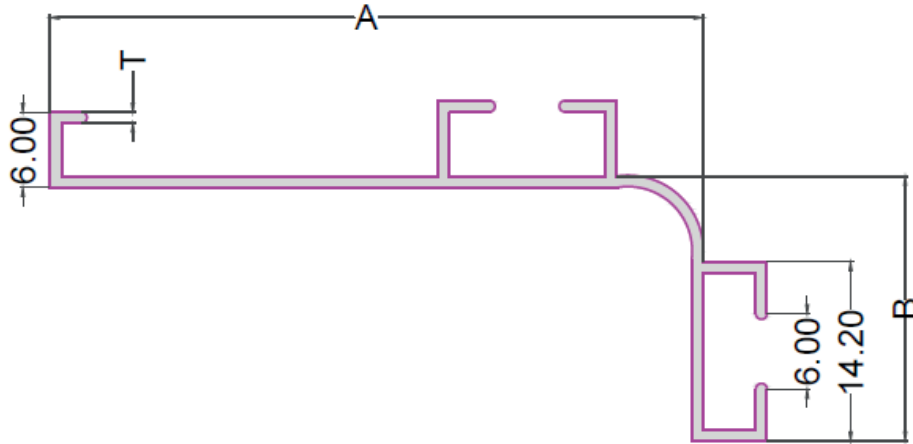

SL NO.	SECTION NO	A	B	T	WEIGHT RANGE KG/12'
1	1346	57.00	27.00	0.90	0.900-1.000

H-2014

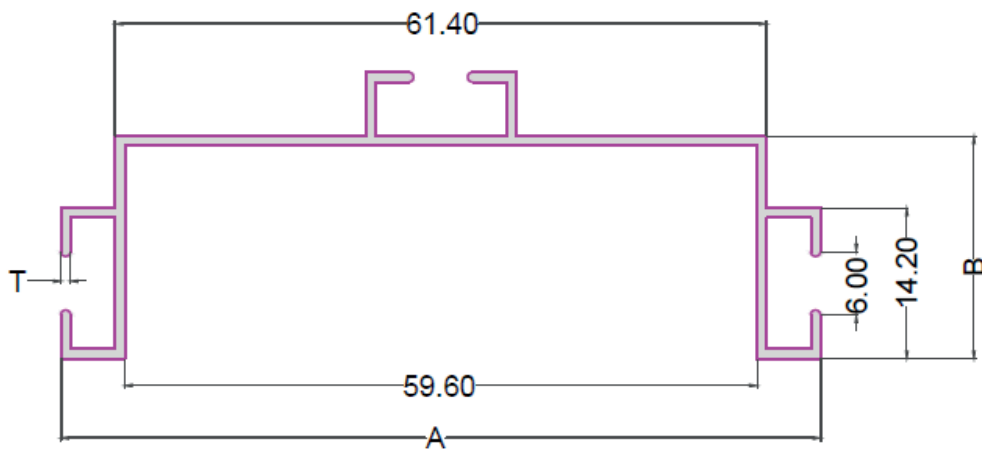

SL NO.	SECTION NO	A	B	T	WEIGHT RANGE KG/12'
1	1347	71.60	27.00	0.90	1.200-1.400

N-19

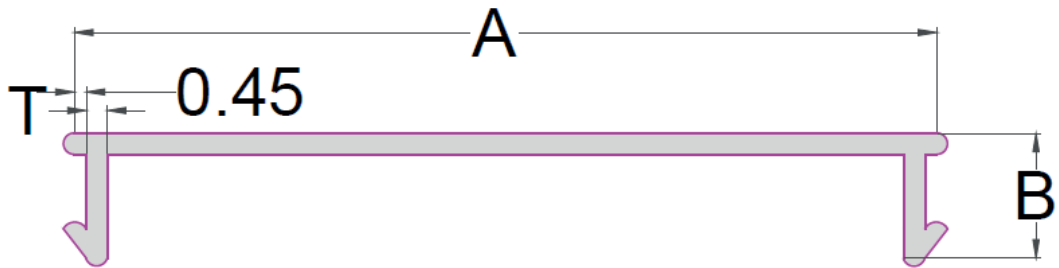

SL NO.	SECTION NO	A	B	T	WEIGHT RANGE KG/12'
1	1348	32.50	4.70	0.80	0.350-0.550

N-20

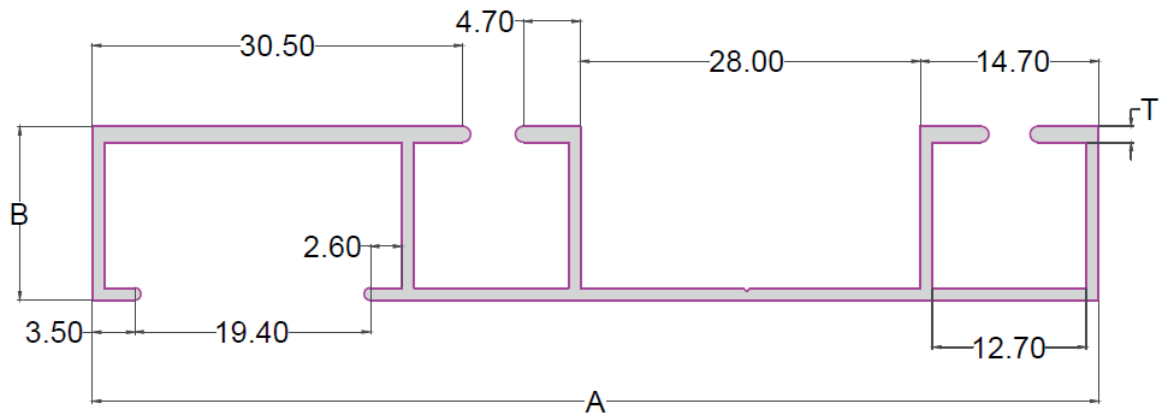

SL NO.	SECTION NO	A	B	T	WEIGHT RANGE KG/12'
1	1349	82.90	14.30	1.00	1.550-1.750

N-21

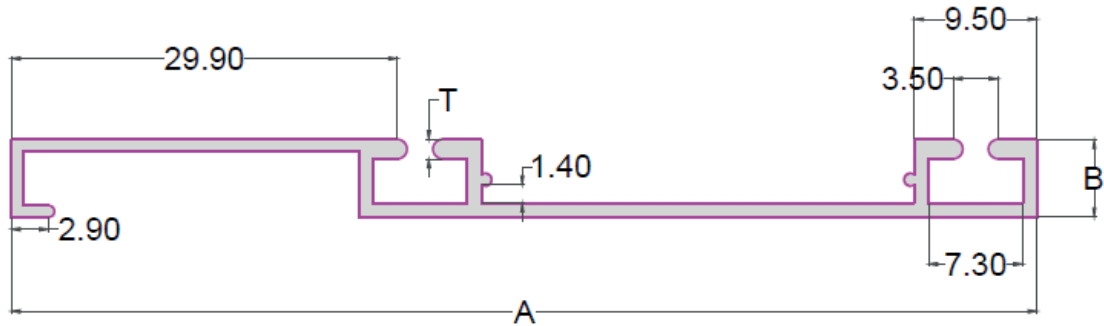

SL NO.	SECTION NO	A	B	T	WEIGHT RANGE KG/12'
1	1350	79.40	6.00	1.10	1.000-1.200

N-29

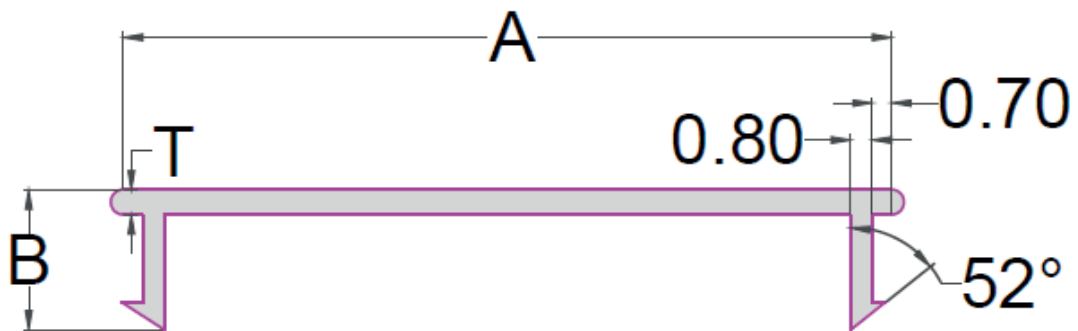

SL NO.	SECTION NO	A	B	T	WEIGHT RANGE KG/12'
1	1351	27.50	5.07	0.90	0.350-0.550

N-30

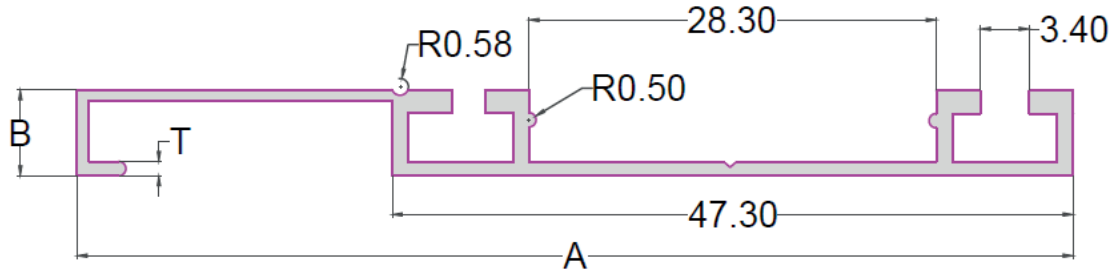

SL NO.	SECTION NO	A	B	T	WEIGHT RANGE KG/12'
1	1352	69.20	6.00	0.80	1.100-1.300

N-31

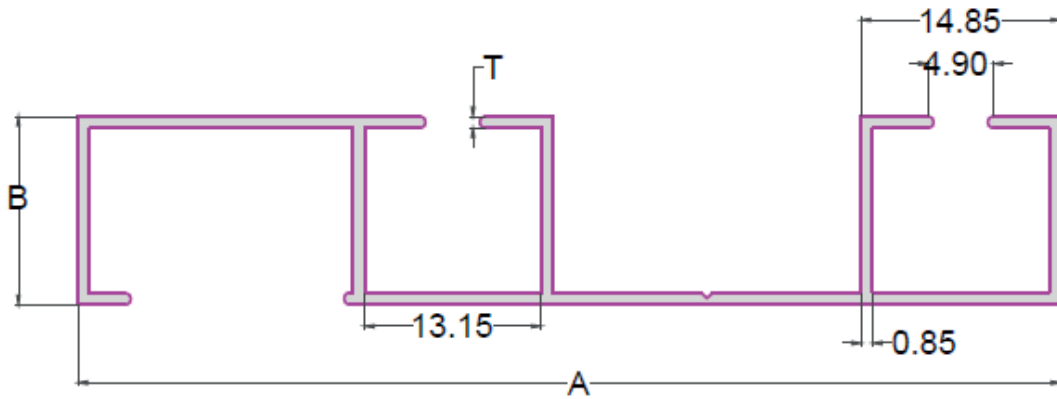

SL NO.	SECTION NO	A	B	T	WEIGHT RANGE KG/12'
1	1353	73.20	14.00	0.85	0.800-1.000

A-1800

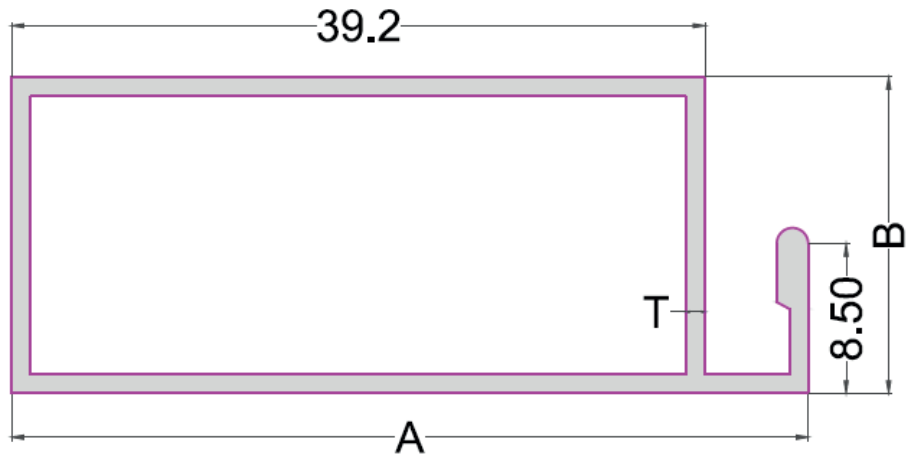

SL NO.	SECTION NO	A	B	T	WEIGHT RANGE KG/12'
1	1354	45.35	18.00	1.10	1.000-1.300
2	1355	45.35	18.00	1.15	1.500-1.800

A-1801

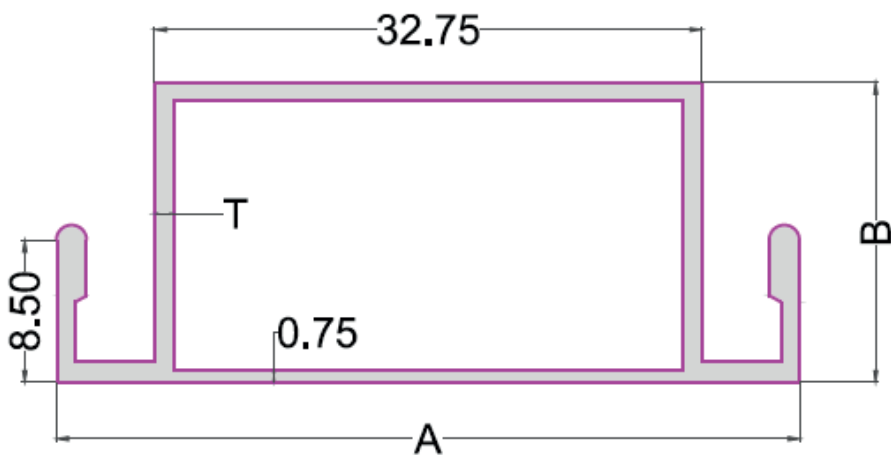

SL NO.	SECTION NO	A	B	T	WEIGHT RANGE KG/12'
1	1356	44.50	18.00	1.10	1.200-1.500
2	1357	44.50	18.00	1.15	1.600-1.900

A-1802

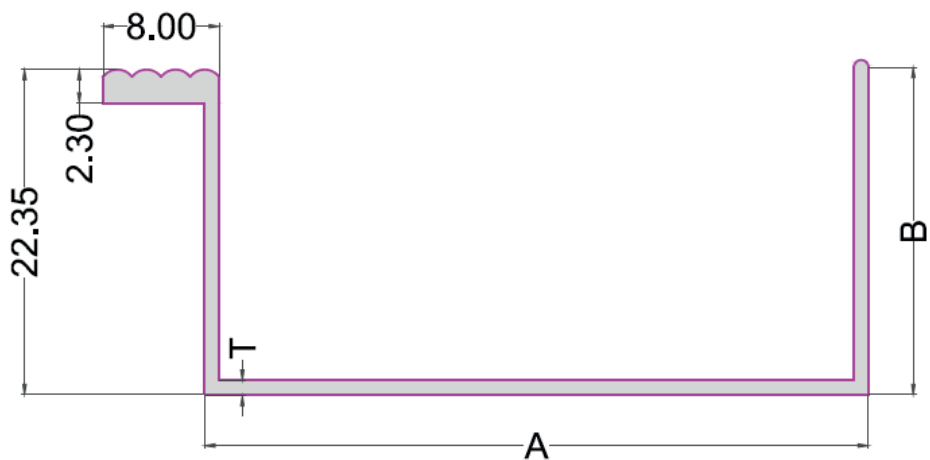

SL NO.	SECTION NO	A	B	T	WEIGHT RANGE KG/12'
1	1358	45.65	22.50	1.00	1.000-1.300

A-1803

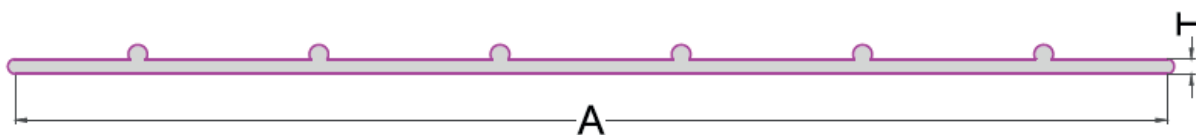

SL NO.	SECTION NO	A	T	WEIGHT RANGE KG/12'
1	1359	71.50	1.80	0.700-1.000

A-1804

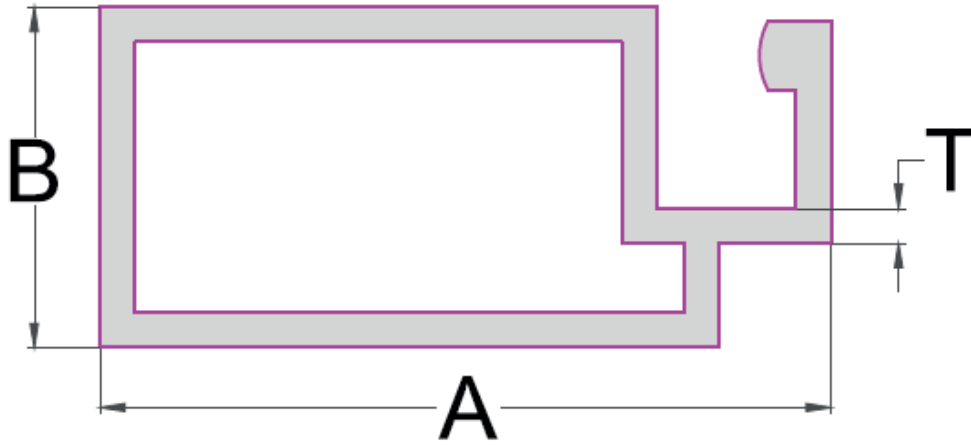

SL NO.	SECTION NO	A	B	T	WEIGHT RANGE KG/12'
1	1360	21.00	9.80	1.00	0.600-0.900

A-1805

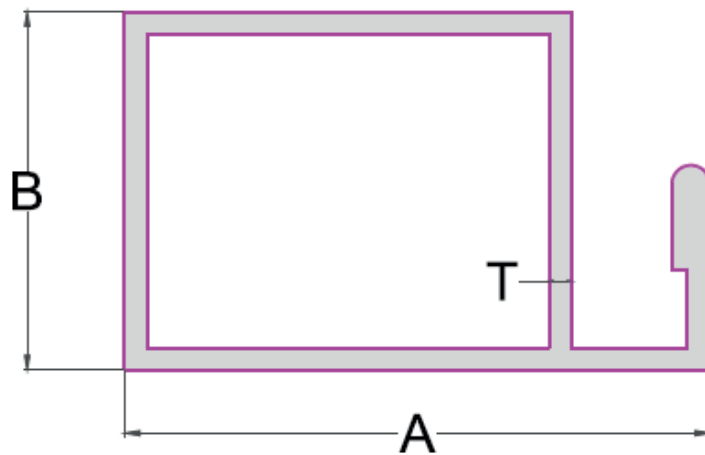

SL NO.	SECTION NO	A	B	T	WEIGHT RANGE KG/12'
1	1361	27.40	16.80	1.05	1.000-1.300

DIE NO 1304

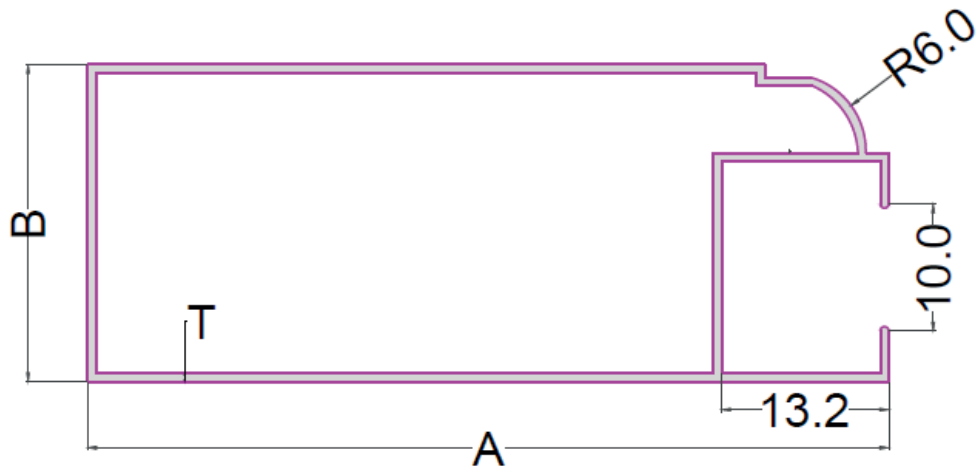

SL NO.	SECTION NO	A	B	T	WEIGHT RANGE KG/12'
1	1362	63.3	25.0	0.65	1.500-1.700

DIE NO 1307

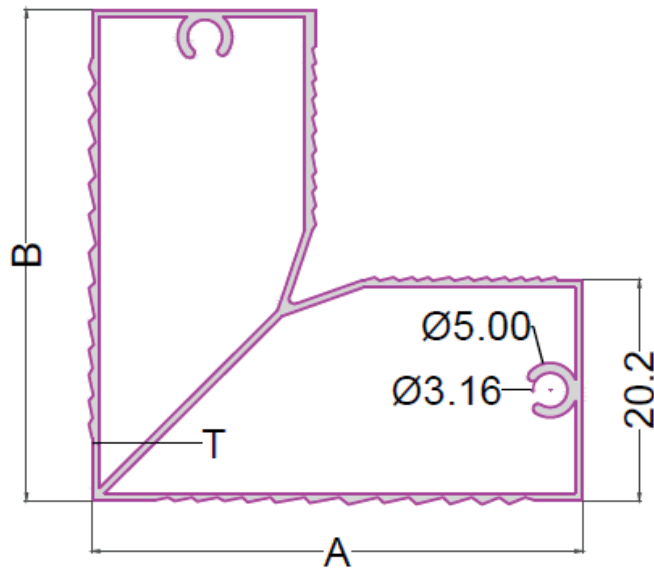

SL NO.	SECTION NO	A	B	T	WEIGHT RANGE KG/12'
1	1363	45.00	45.00	0.66	3.000-3.200

DIE NO 1308

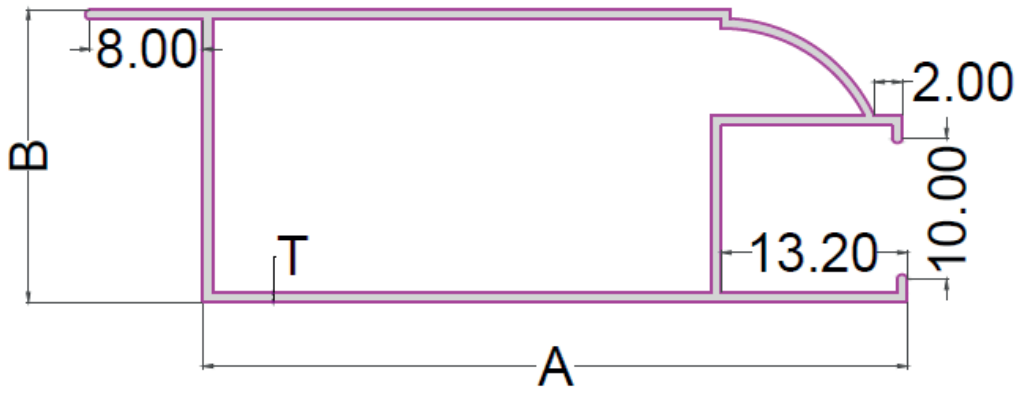

SL NO.	SECTION NO	A	B	T	WEIGHT RANGE KG/12'
1	1364	50.00	20.7	0.70	1.000-1.200

TEXTILE SERIES

TEXTILE 1



SL NO.	SECTION NO	A	B	T	WEIGHT RANGE KG/12'
1	1365	66.90	23.84	-	6.000-6.300

TEXTILE 2

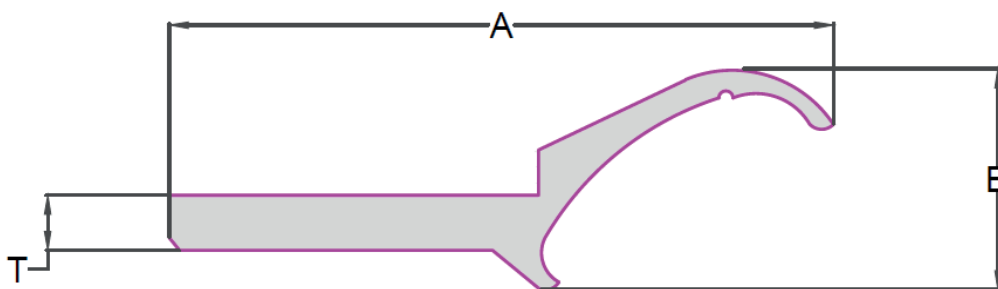

SL NO.	SECTION NO	A	B	T	WEIGHT RANGE KG/12'
1	1366	70.00	24.10	8.00	5.000-5.200

TEXTILE 3

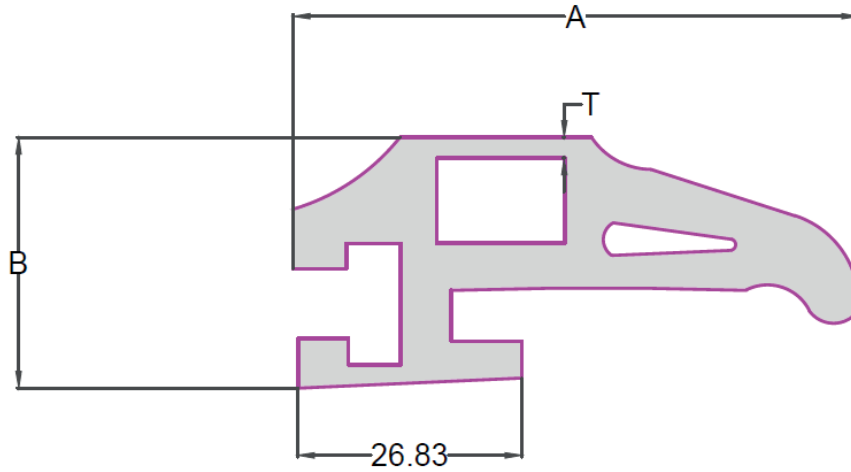

SL NO.	SECTION NO	A	B	T	WEIGHT RANGE KG/12'
1	1367	67.02	30.00	1.70	6.500-6.800

TEXTILE 4

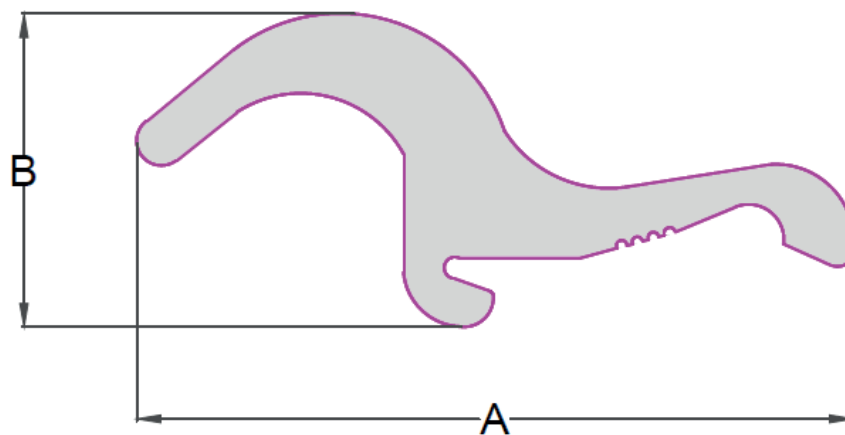

SL NO.	SECTION NO	A	B	T	WEIGHT RANGE KG/12'
1	1368	61.20	25.5	9.80	4.200-4.400

UNIVERSAL

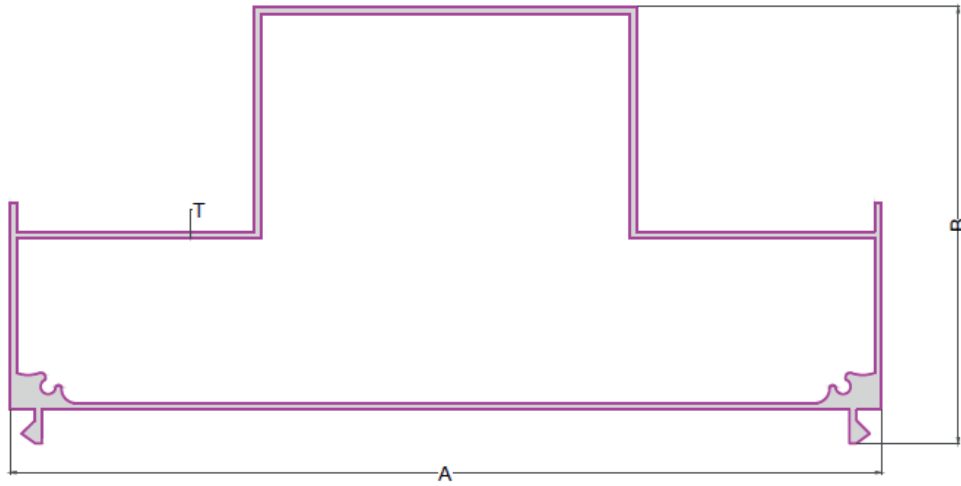

SL NO.	SECTION NO	A	B	T	WEIGHT RANGE KG/12'
1	1369	104.00	52.10	0.80	8.000-8.300

DIE NO 9028

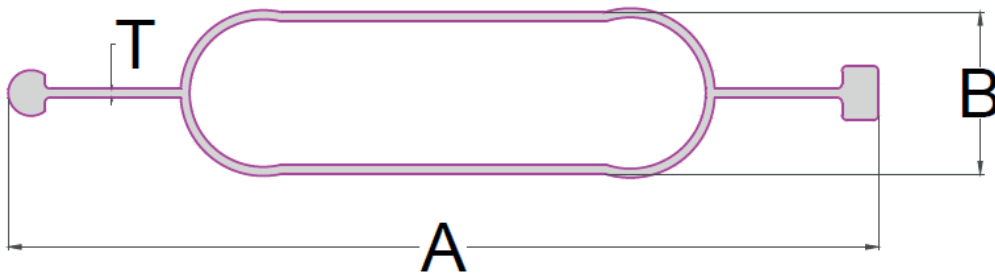

SL NO.	SECTION NO	A	B	T	WEIGHT RANGE KG/12'
1	1370	48.00	8.90	0.50	0.450-0.550
2	1371	48.00	8.90	0.60	0.650-0.850

DIE NO 9029

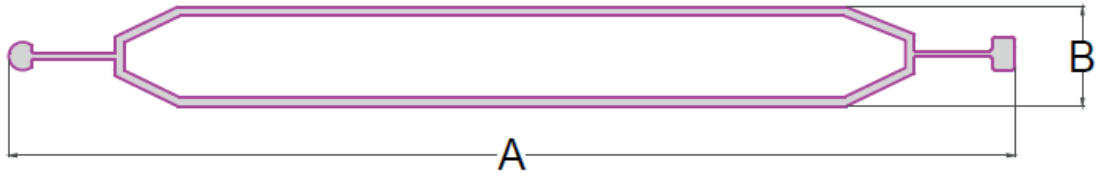

SL NO.	SECTION NO	A	B	T	WEIGHT RANGE KG/12'
1	1372	90.00	9.00	0.80	1.650-1.850

DIE NO 9030

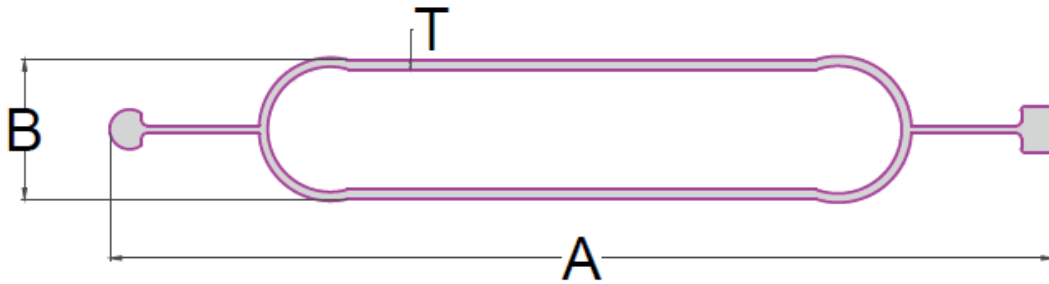

SL NO.	SECTION NO	A	B	T	WEIGHT RANGE KG/12'
1	1373	60.00	9.00	0.60	0.800-1.000

DIE NO 9031

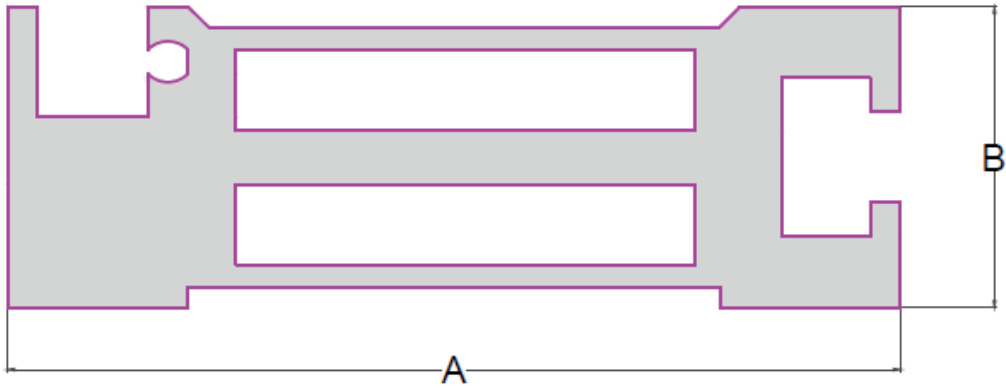

SL NO.	SECTION NO	A	B	WEIGHT RANGE KG/12'
1	1374	89.00	30.00	13.800-14.000

PHOTOFRAME SERIES

PHOTOFRAME

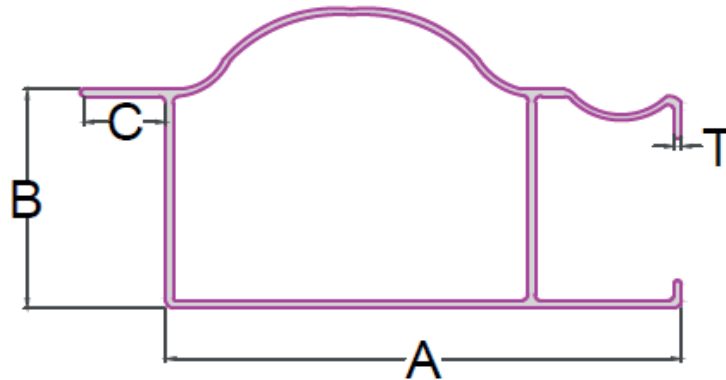

SL NO.	SECTION NO	A	B	C	T	WEIGHT RANGE KG/12'
1	1375	36.00	15.30	3.00	0.80	0.800-0.900
2	1376	36.00	15.30	5.00	0.60	0.700-0.800
3	1377	36.00	15.30	5.00	0.85	0.900-1.000
4	1378	36.00	15.30	6.00	0.85	0.750-0.900
5	1379	36.00	15.30	10.00	0.90	1.000-1.200

Y PHOTOFRAME

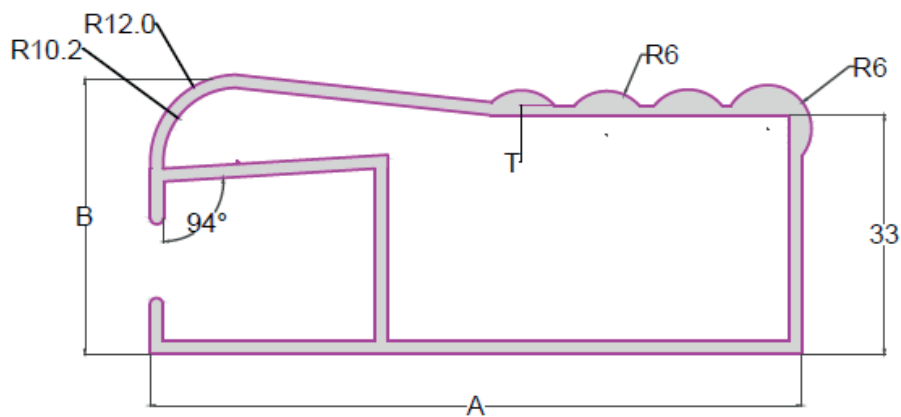

SL NO.	SECTION NO	A	B	T	WEIGHT RANGE KG/12'
1	1380	90.00	38.00	1.80	1.300-1.500

APC PHOTOFRAME

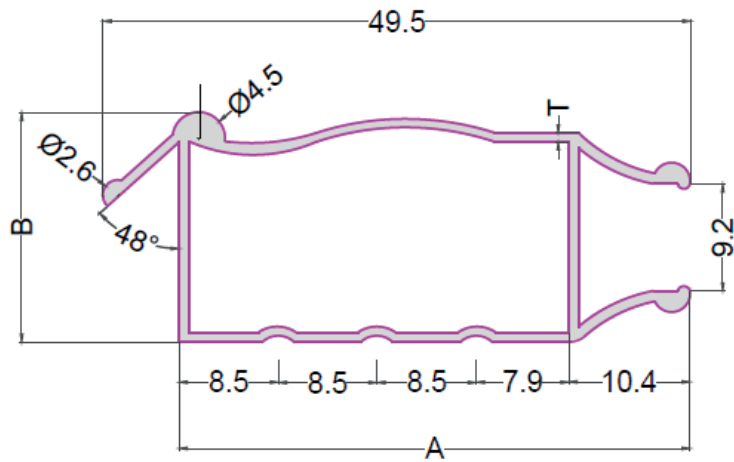

SL NO.	SECTION NO	A	B	T	WEIGHT RANGE KG/12'
1	1381	43.80	20.70	0.85	1.300-1.500

PHOTO FRAME

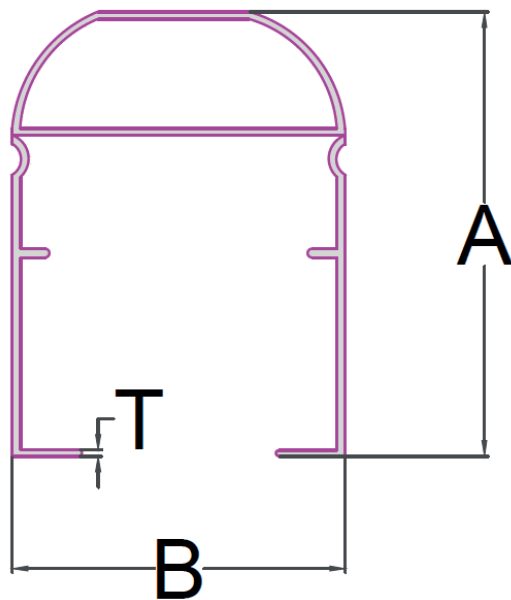

SL NO.	SECTION NO	A	B	T	WEIGHT RANGE KG/12'
1	1382	20.00	15.00	0.42	0.300-0.400

FLAT SERIES

ROUND FLAT

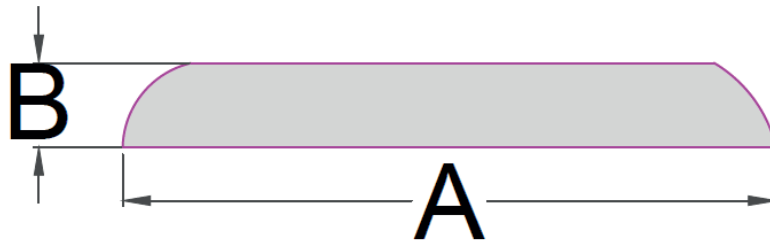

SL NO.	SECTION NO	A	B	WEIGHT RANGE KG/12'
1	1383	25.00	3.00	0.750-0.800

SQUARE FLAT

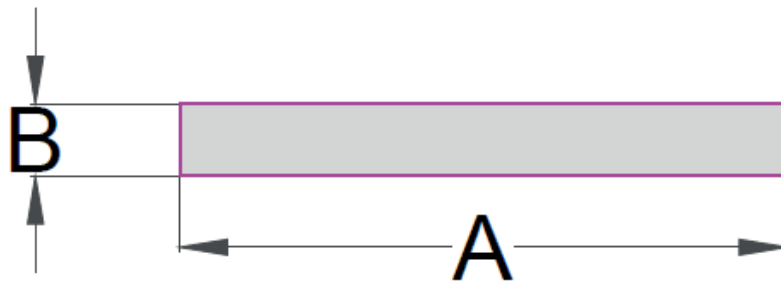

SL NO.	SECTION NO	A	B	T	WEIGHT RANGE KG/12'
1	1384	12.00	6.00	1.90	0.650-0.750
2	1385	19.00	2.00	0.95	0.350-0.450
3	1386	19.00	3.00	1.00	0.400-0.500
4	1387	19.00	6.00	2.24	1.100-1.200
5	1388	20.00	10.00	3.50	2.100-2.300
6	1389	25.00	1.50	0.71	0.350-0.450
7	1390	25.00	2.00	0.98	0.500-0.600
8	1391	25.00	3.00	1.30	0.700-0.800
9	1392	25.00	5.00	2.08	1.200-1.300
10	1393	25.00	6.00	2.50	1.500-1.600
11	1394	25.00	10.00	3.60	2.500-2.600
12	1395	25.00	12.00	4.00	3.000-3.300
13	1396	30.00	6.00	2.40	1.700-1.800
14	1397	30.00	10.00	3.70	3.000-3.300
15	1398	30.00	12.00	4.20	3.400-3.600
16	1399	32.00	3.00	1.35	0.900-1.000

17	1400	38.00	3.00	1.36	1.100-1.200
18	1401	38.00	6.00	2.68	2.300-2.400
19	1402	40.00	5.00	2.10	1.900-2.000
20	1403	40.00	6.00	2.50	2.300-2.500
21	1404	40.00	10.00	4.10	4.000-4.200
22	1405	50.00	4.00	1.94	2.000-2.200
23	1406	50.00	5.00	2.27	2.450-2.600
24	1407	50.00	6.00	2.64	2.950-3.100
25	1408	50.00	10.00	4.16	5.000-5.200
26	1409	50.00	12.00	4.75	5.800-6.100
27	1410	60.00	3.00	1.70	2.000-2.200
28	1411	60.00	5.00	2.35	3.000-3.200
29	1412	60.00	12.00	4.90	7.000-7.200
30	1413	63.00	4.00	1.90	2.500-2.600
31	1414	64.00	10.00	4.20	6.200-6.300
32	1415	75.00	3.00	1.34	2.000-2.200
33	1416	75.00	6.00	2.77	4.500-4.600
34	1417	75.00	10.00	4.35	7.400-7.600
35	1418	75.00	12.00	5.17	9.000-9.200
36	1419	80.00	5.00	2.40	4.000-4.200
37	1420	80.00	10.00	4.50	8.000-8.200
38	1421	80.00	12.00	5.16	9.400-9.600
39	1422	100.00	5.00	2.20	4.500-4.700
40	1423	100.00	10.00	4.60	10.000-10.200
41	1424	125.00	3.00	1.46	3.600-3.800
42	1425	125.00	5.00	2.40	6.100-6.300
43	1426	125.00	10.00	4.60	12.400-12.600

BLF 1576

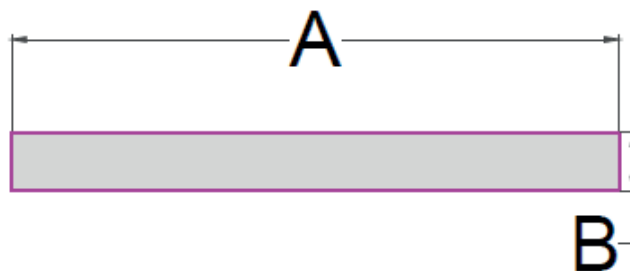

SL NO.	SECTION NO	A	B	WEIGHT RANGE KG/12'
1	1427	29.90	2.90	0.800-1.000

NM SERIES

NM-40

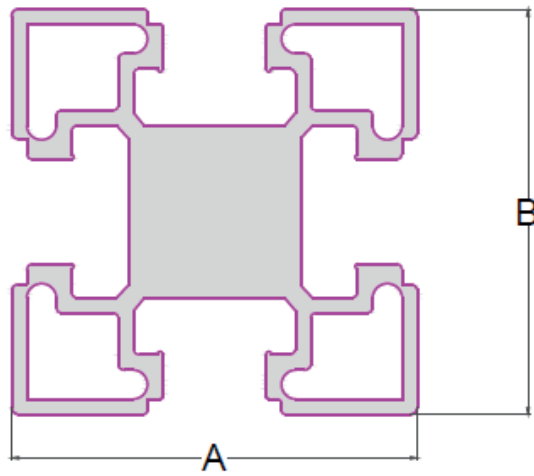

SL NO.	SECTION NO	A	B	WEIGHT RANGE KG/12'
1	1428	40.00	40.00	4.000-4.300

NM-7004

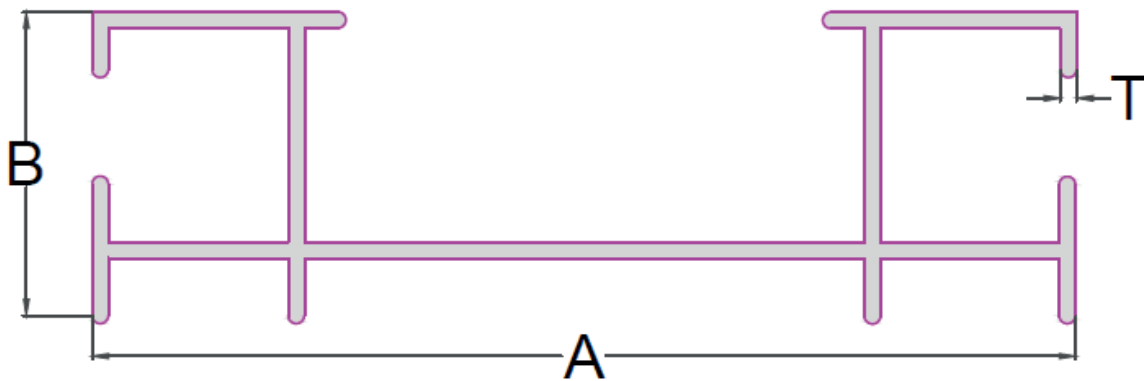

SL NO.	SECTION NO	A	B	T	WEIGHT RANGE KG/12'
1	1429	60.00	19.00	1.00	1.500-1.700

NM-7005

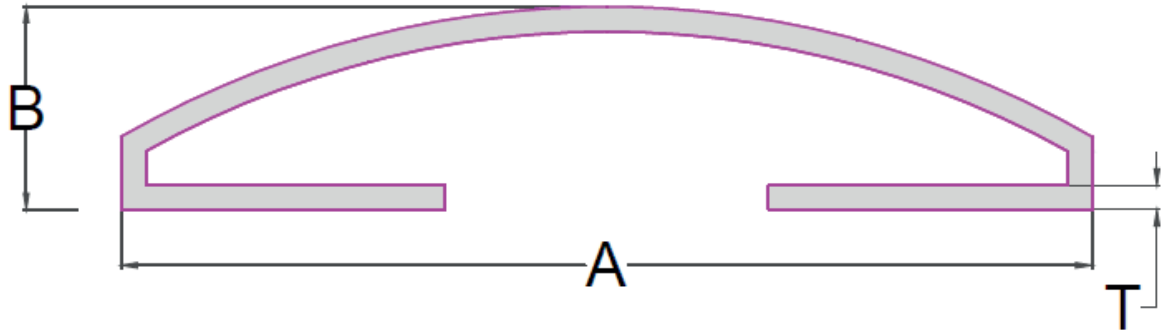

SL NO.	SECTION NO	A	B	T	WEIGHT RANGE KG/12'
1	1430	60.00	12.5	1.50	1.500-1.700

NM-7002

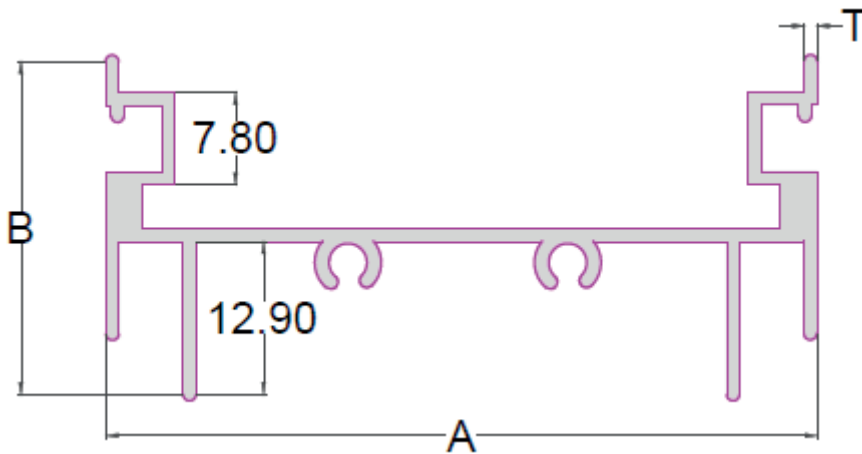

SL NO.	SECTION NO	A	B	T	WEIGHT RANGE KG/12'
1	1431	60.00	28.00	1.10	1.700-1.900

NM-7003

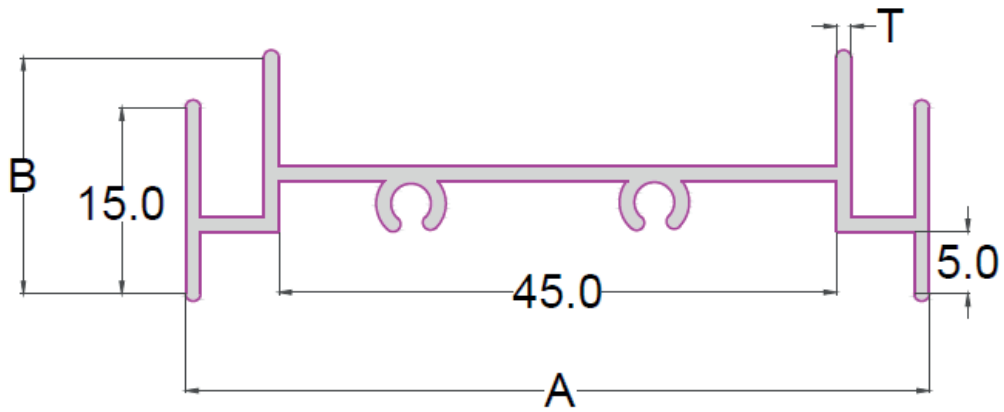

SL NO.	SECTION NO	A	B	T	WEIGHT RANGE KG/12'
1	1432	60.00	19.00	1.20	1.450-1.650

NM-7010

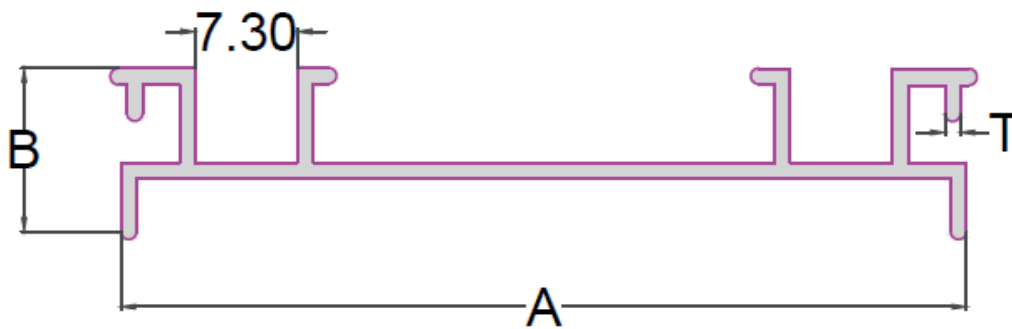

SL NO.	SECTION NO	A	B	T	WEIGHT RANGE KG/12'
1	1433	60.00	11.60	1.10	1.000-1.200

NM-100

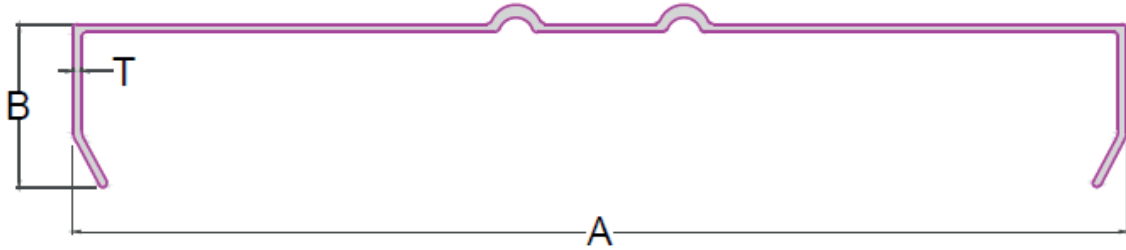

SL NO.	SECTION NO	A	B	T	WEIGHT RANGE KG/12'
1	1434	94.00	15.60	1.60	1.000-1.200

NM-15

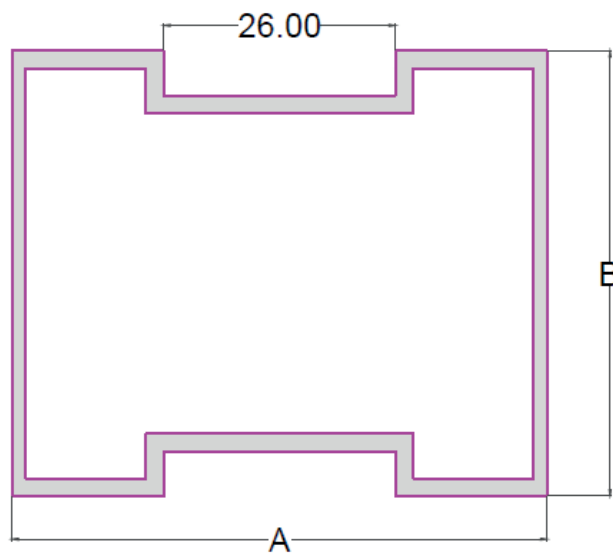

SL NO.	SECTION NO	A	B	WEIGHT RANGE KG/12'
1	1435	60.00	50.00	4.400-4.600
2	1436	60.00	50.00	4.900-5.100

NM-061

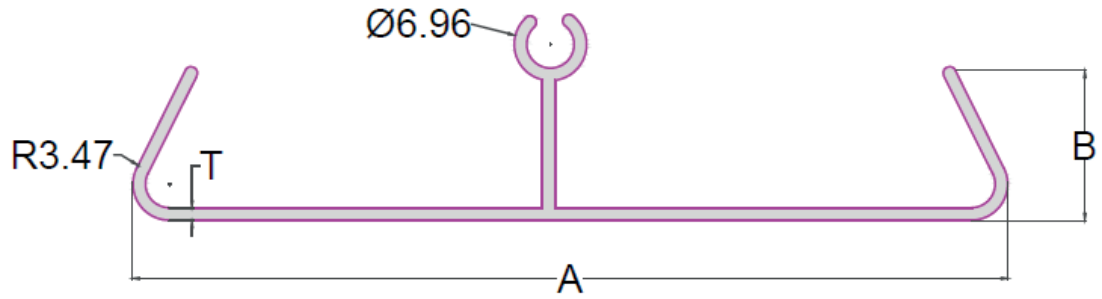

SL NO.	SECTION NO	A	B	T	WEIGHT RANGE KG/12'
1	1437	84.17	16.06	1.20	1.400-1.600

NM-395

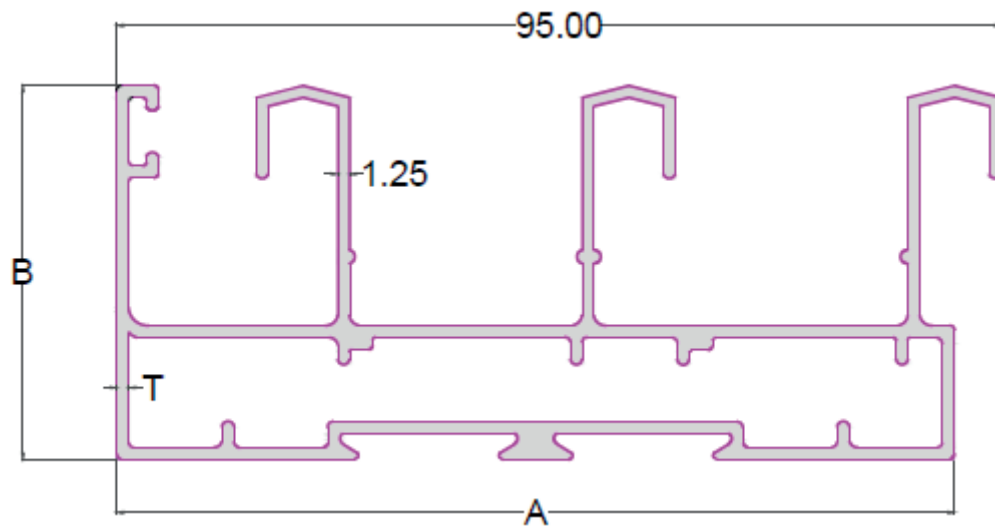

SL NO.	SECTION NO	A	B	T	WEIGHT RANGE KG/12'
1	1338	90.00	40.20	1.30	5.400-5.600

SOLAR SERIES

SOLAR C CHANNEL

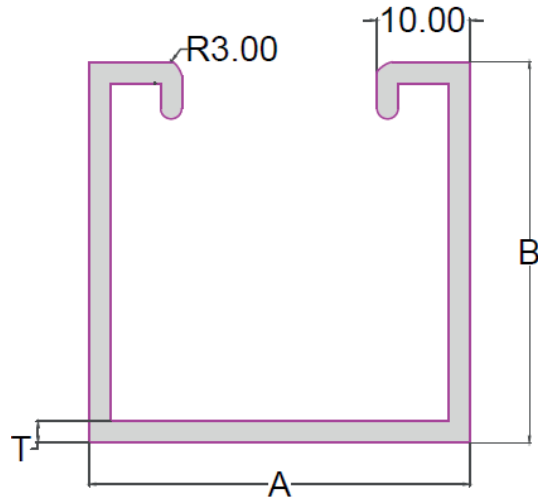

SL NO.	SECTION NO	A	B	T	WEIGHT RANGE KG/12'
1	1439	41.00	41.00	2.30	3.000-3.200

SOLAR T CHANNEL

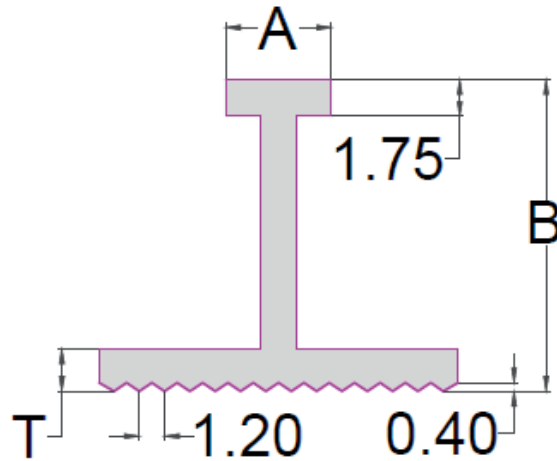

SL NO.	SECTION NO	A	B	T	WEIGHT RANGE KG/12'
1	1440	17.00	14.75	1.75	0.500-0.700

SOLAR J CHANNEL

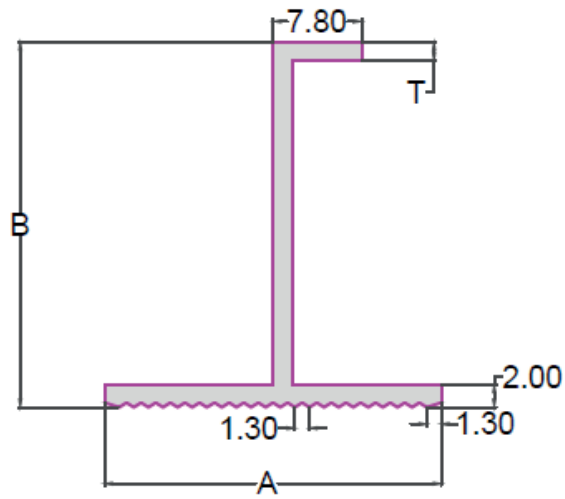

SL NO.	SECTION NO	A	B	T	WEIGHT RANGE KG/12'
1	1441	29.90	32.50	1.65	1.000-1.200

SOLAR Z CLEMP

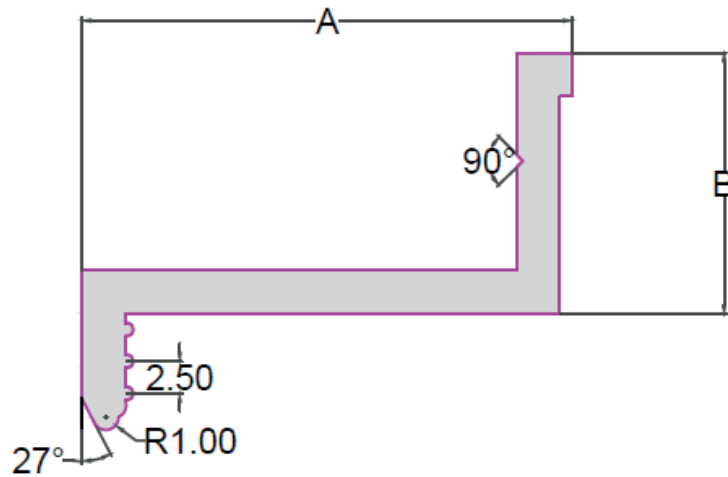

SL NO.	SECTION NO	A	B	T	WEIGHT RANGE KG/12'
1	1442	37.50	30.60	3.40	2.000-2.200

SOLAR BRACKET 42 MM

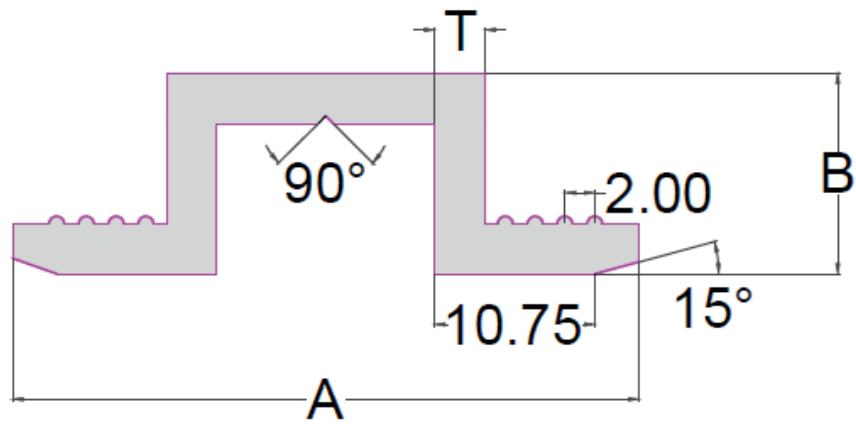

SL NO.	SECTION NO	A	B	T	WEIGHT RANGE KG/12'
1	1443	42.00	13.50	3.40	2.000-2.200

SOLAR RAILINGS

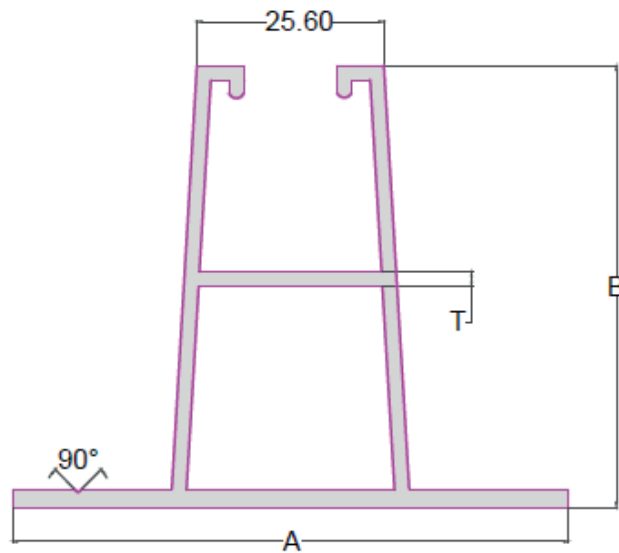

SL NO.	SECTION NO	A	B	T	WEIGHT RANGE KG/12'
1	1444	76.20	60.50	2.00	4.800-5.000

64 MM CHANNEL

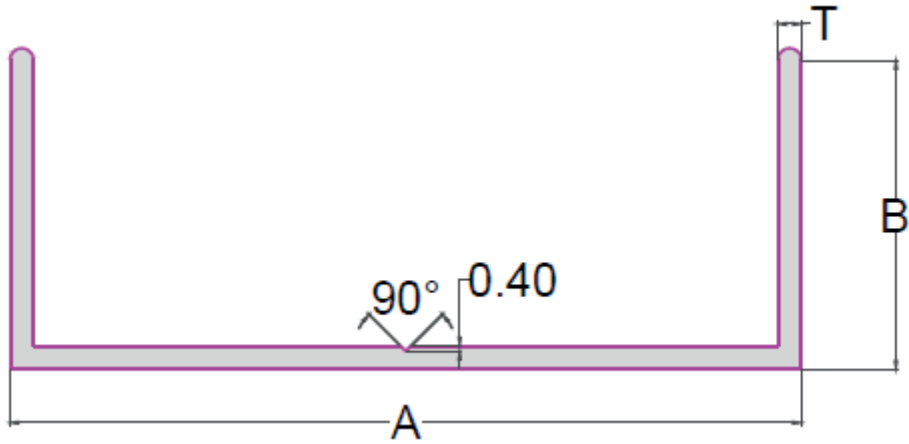

SL NO.	SECTION NO	A	B	T	WEIGHT RANGE KG/12'
1	1445	64.00	25.00	1.90	1.900-2.000

59 MM CHANNEL

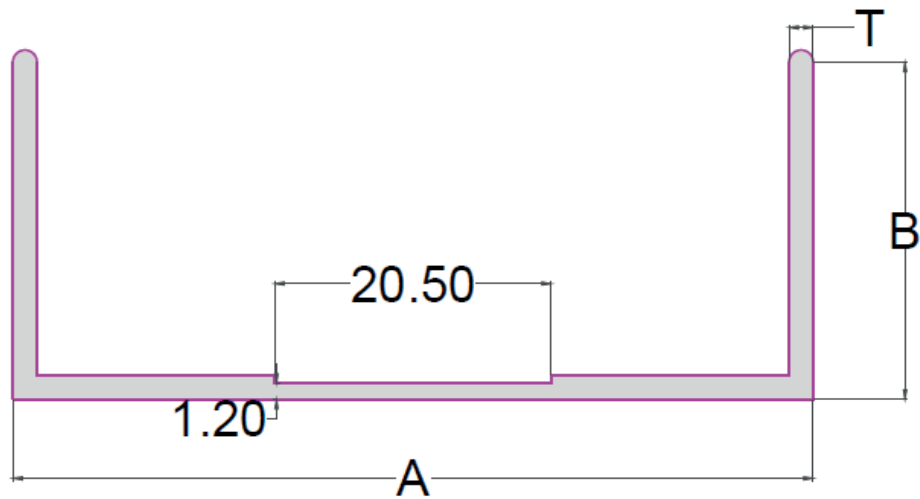

SL NO.	SECTION NO	A	B	T	WEIGHT RANGE KG/12'
1	1446	59.40	25.00	1.80	1.600-1.800

BFS SERIES

BFS-18 MM ROUND PIPE

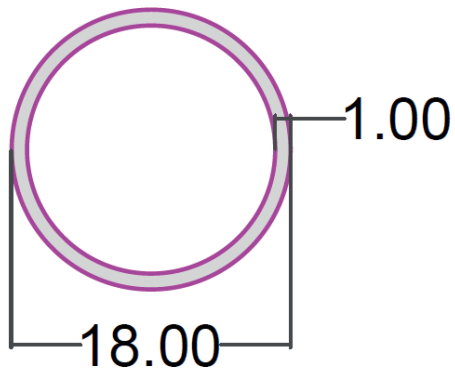

SL NO.	SECTION NO	A	T	WEIGHT RANGE KG/12'
1	1447	18.00	1.00	0.530
2	1448	18.00	1.20	0.610
3	1449	18.00	1.40	0.740
4	1450	18.00	1.60	0.800
5	1451	18.00	1.75	0.880

BFS-233

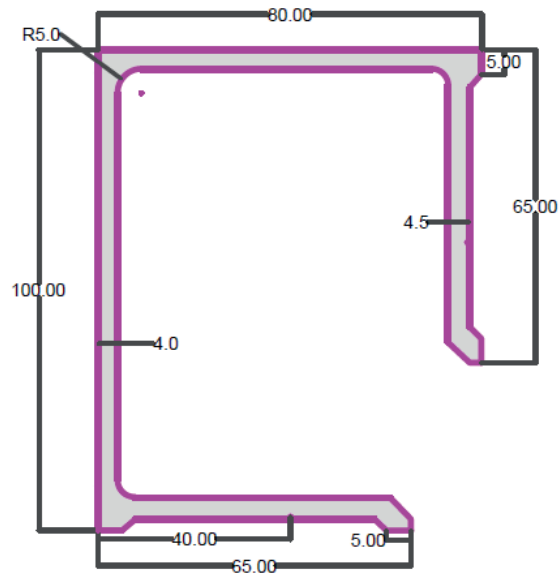

SL NO.	SECTION NO	A	B	T	WEIGHT RANGE KG/12'
1	1452	80.00	100.00	4.00	12.000-12.200

BFS-236

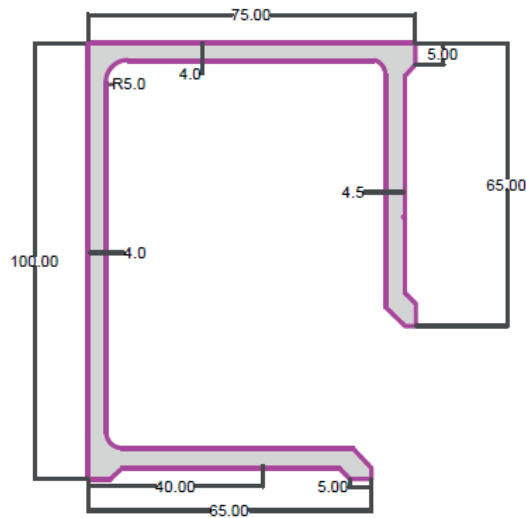

SL NO.	SECTION NO	A	B	T	WEIGHT RANGE KG/12'
1	1453	75.00	100.00	4.00	11.600-11.800

BFS-339

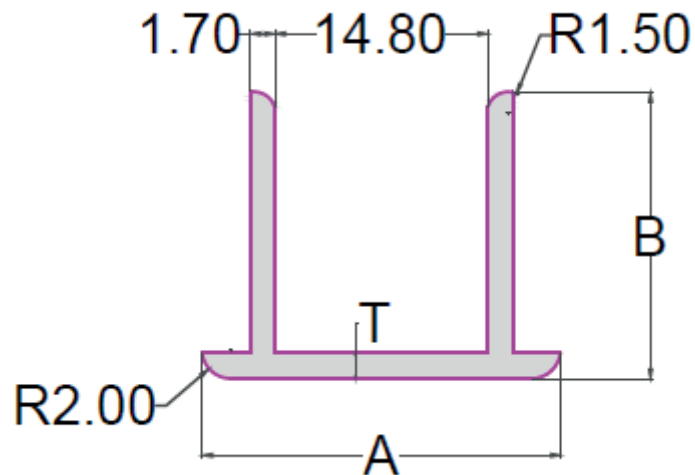

SL NO.	SECTION NO	A	B	T	WEIGHT RANGE KG/12'
1	1454	24.90	19.90	1.80	1.000-1.200

BFS-375

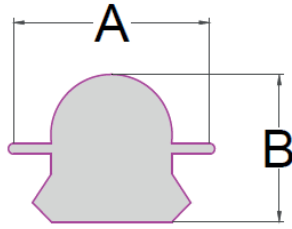

SL NO.	SECTION NO	A	B	WEIGHT RANGE KG/12'
1	1455	9.30	7.00	0.300-0.400

BFS-379

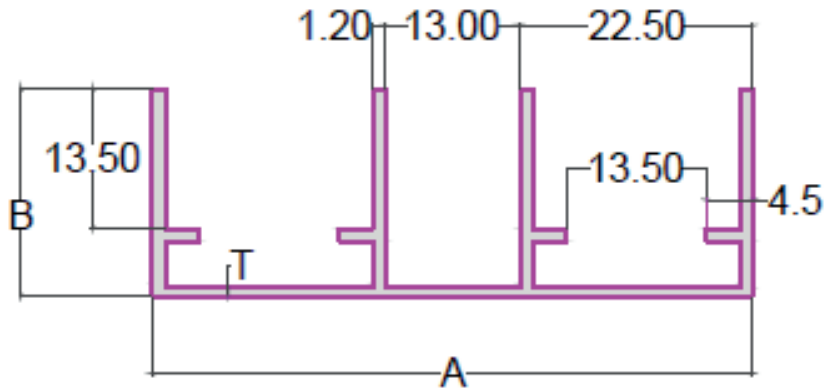

SL NO.	SECTION NO	A	B	T	WEIGHT RANGE KG/12'
1	1456	58.00	20.00	0.80	1.000-1.200

BFS-381

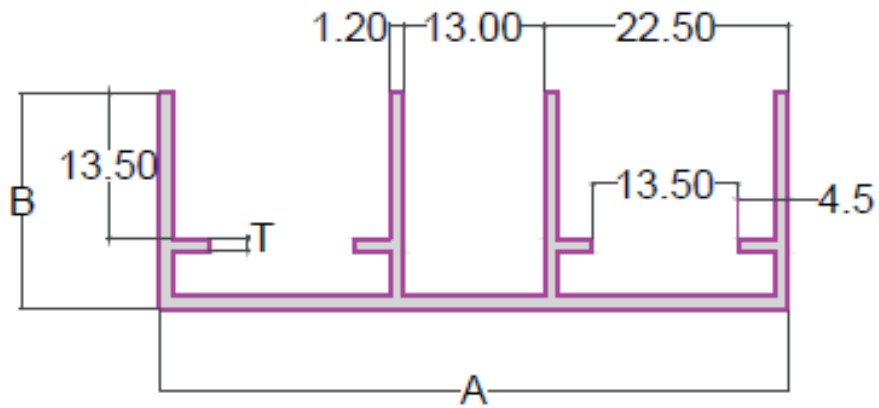

SL NO.	SECTION NO	A	B	T	WEIGHT RANGE KG/12'
1	1457	58.00	20.00	1.10	1.500-1.700

BFS-382

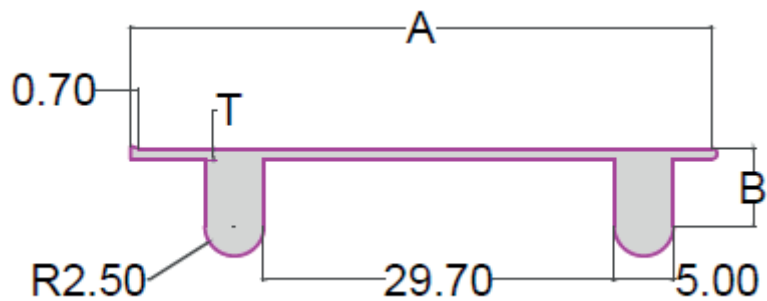

SL NO.	SECTION NO	A	B	T	WEIGHT RANGE KG/12'
1	1458	49.20	6.60	0.90	0.900-1.000

BFS-383

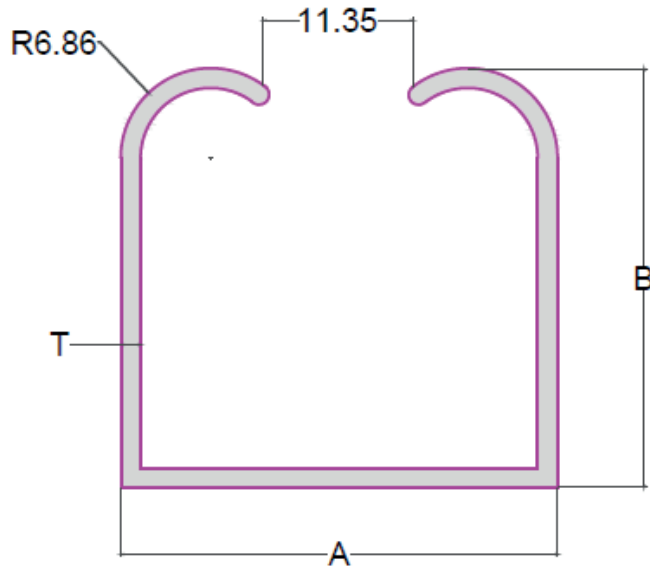

SL NO.	SECTION NO	A	B	T	WEIGHT RANGE KG/12'
1	1459	33.35	32.00	1.50	1.500-1.700

BFS-384

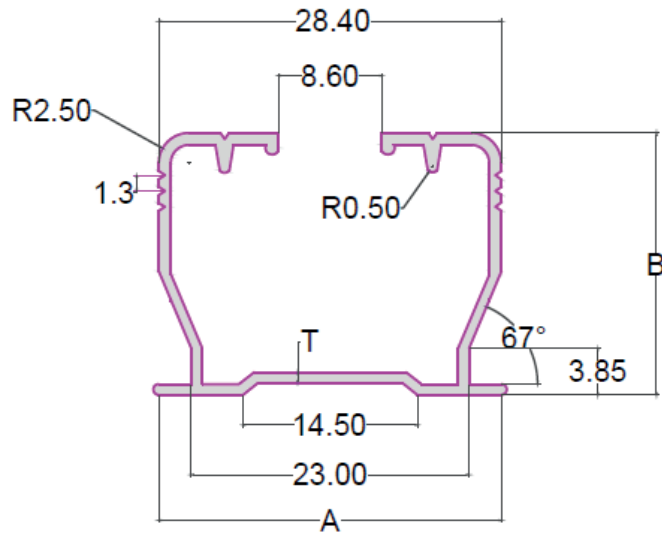

SL NO.	SECTION NO	A	B	T	WEIGHT RANGE KG/12'
1	1460	28.40	21.70	0.90	0.700-0.900

BFS-385

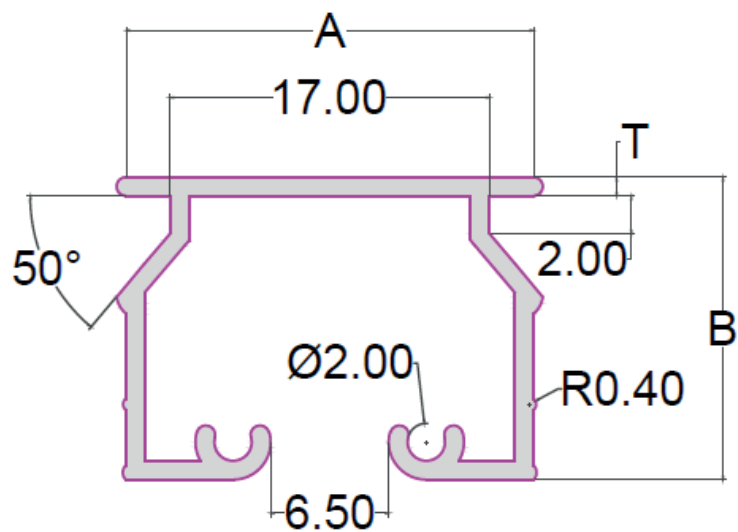

SL NO.	SECTION NO	A	B	T	WEIGHT RANGE KG/12'
1	1461	21.70	16.10	1.00	0.800-1.000

BFS-386

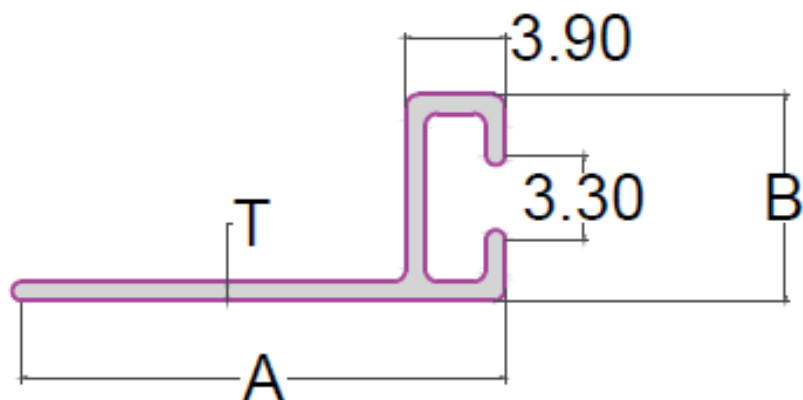

SL NO.	SECTION NO	A	B	T	WEIGHT RANGE KG/12'
1	1462	19.00	8.10	0.75	0.200-0.400

BFS-541

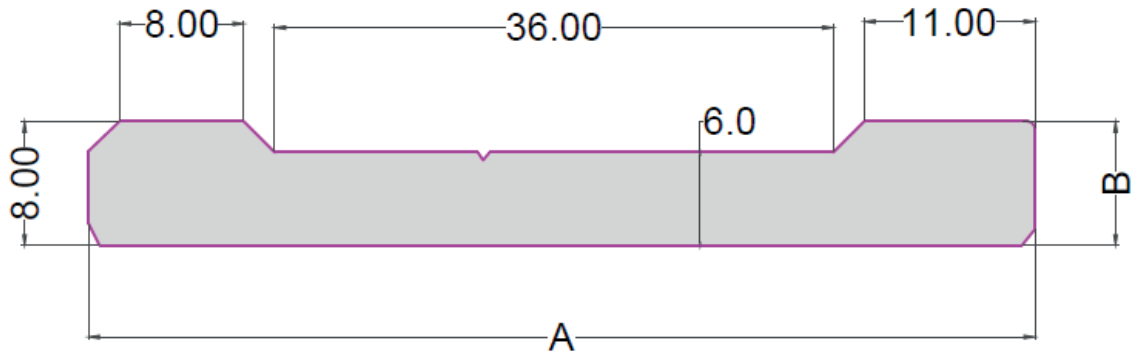

SL NO.	SECTION NO	A	B	WEIGHT RANGE KG/12'
1	1463	61.00	8.00	3.800-4.000

BFS-542

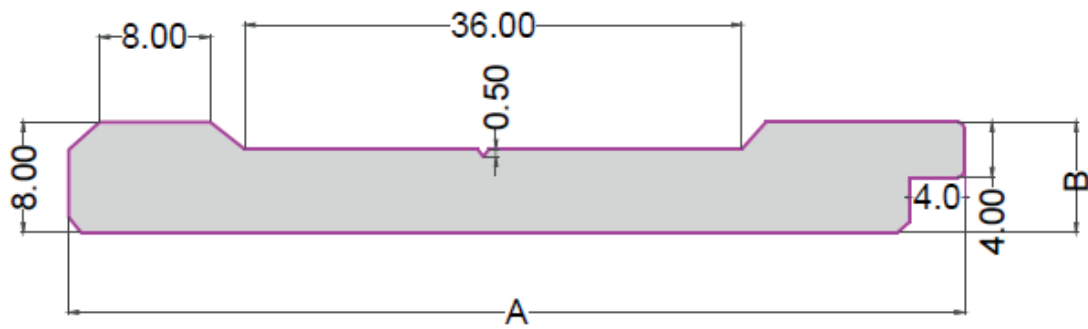

SL NO.	SECTION NO	A	B	WEIGHT RANGE KG/12'
1	1464	65.00	8.00	3.800-4.000

BFS-552

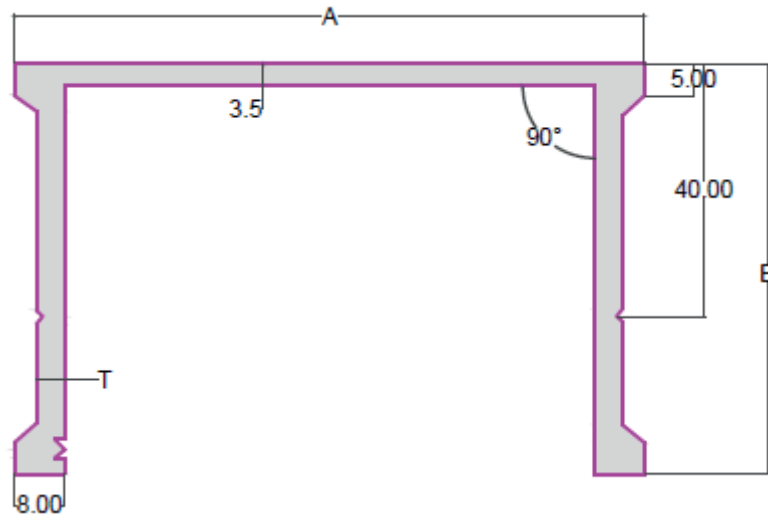

SL NO.	SECTION NO	A	B	T	WEIGHT RANGE KG/12'
1	1465	100.00	65.00	4.50	9.000-9.500

BFS-555

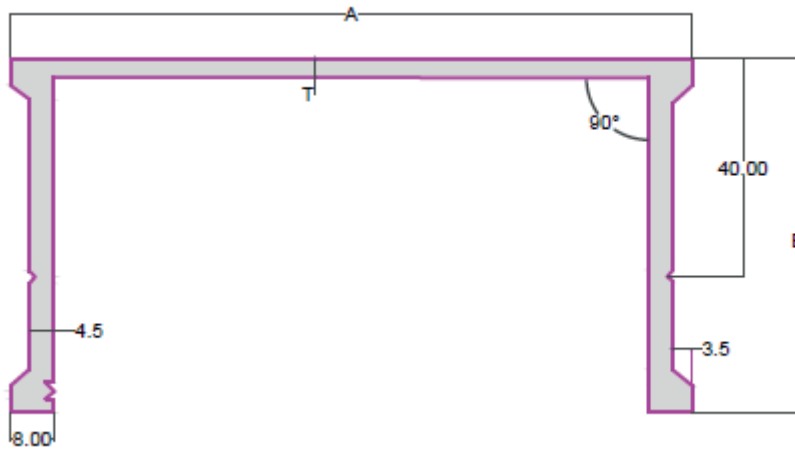

SL NO.	SECTION NO	A	B	T	WEIGHT RANGE KG/12'
1	1466	125.00	65.00	3.5	10.000-10.300

BFS-1097

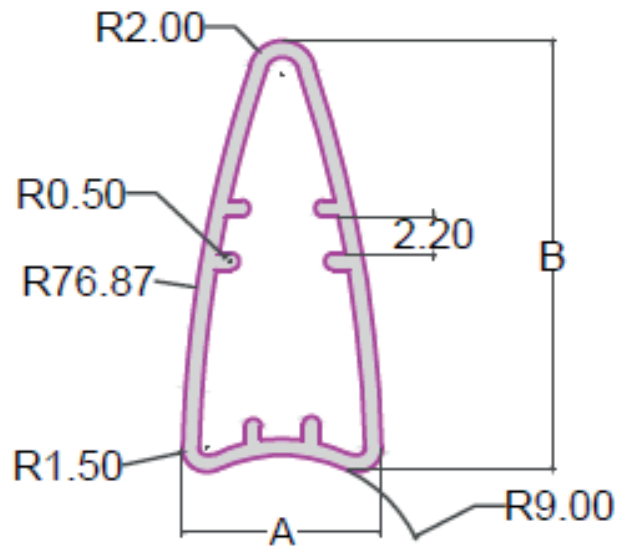

SL NO.	SECTION NO	A	B	T	WEIGHT RANGE KG/12'
1	1467	12.00	27.20	1.00	0.700-0.900

BFS-1104

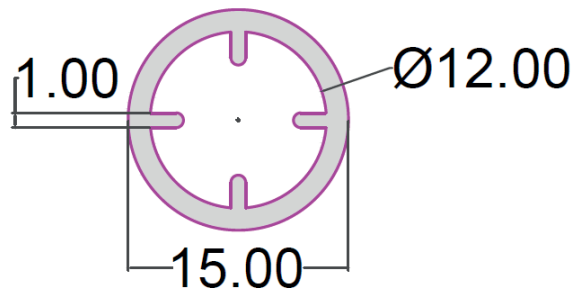

SL NO.	SECTION NO	A	T	WEIGHT RANGE KG/12'
1	1468	15.00	1.50	0.600-0.800

65 X 65 ANGLE

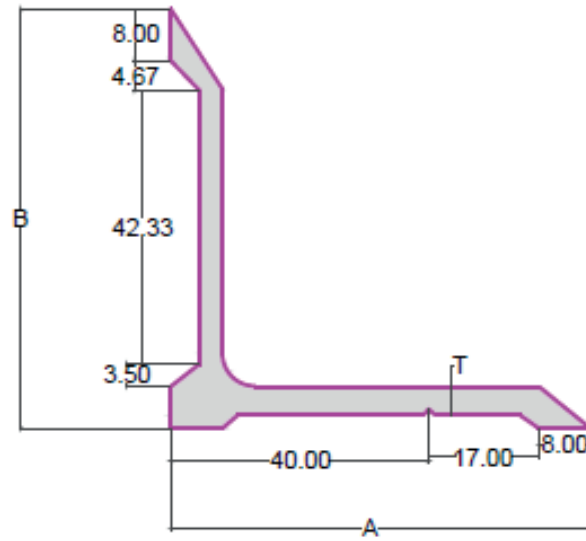

SL NO.	SECTION NO	A	B	T	WEIGHT RANGE KG/12'
1	1469	65.00	65.00	4.50	5.500-5.700

110 X 65 ANGLE

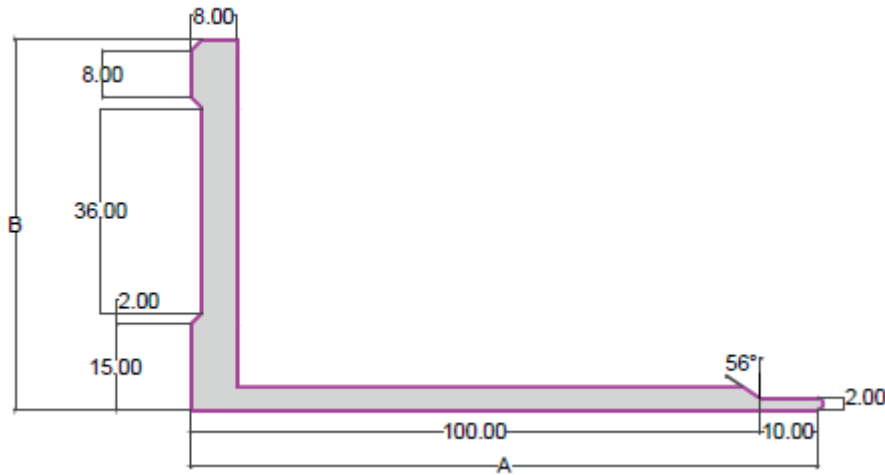

SL NO.	SECTION NO	A	B	WEIGHT RANGE KG/12'
1	1470	110.00	65.00	8.200-8.500

135 X 65 ANGLE



SL NO.	SECTION NO	A	B	WEIGHT RANGE KG/12'
1	1471	135.00	65.00	9.200-9.500

5" C HANDLE

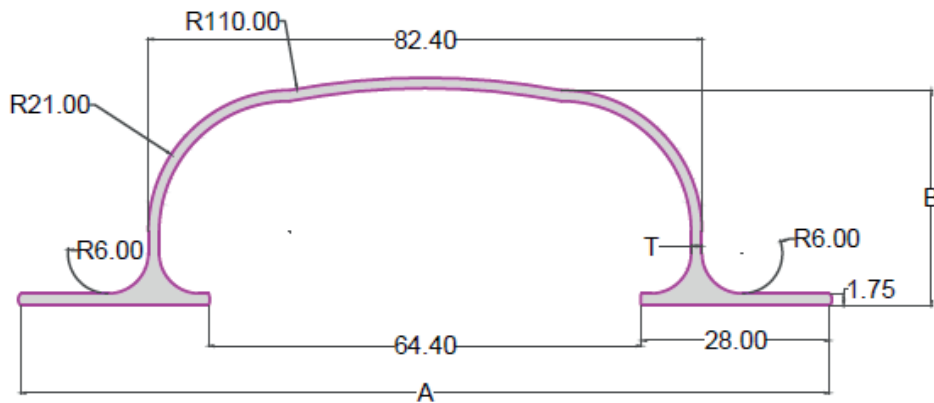

SL NO.	SECTION NO	A	B	T	WEIGHT RANGE KG/12'
1	1472	120.40	33.20	1.50	2.900-3.200
2	1473	120.40	33.20	1.60	3.300-3.600

5" D HANDLE

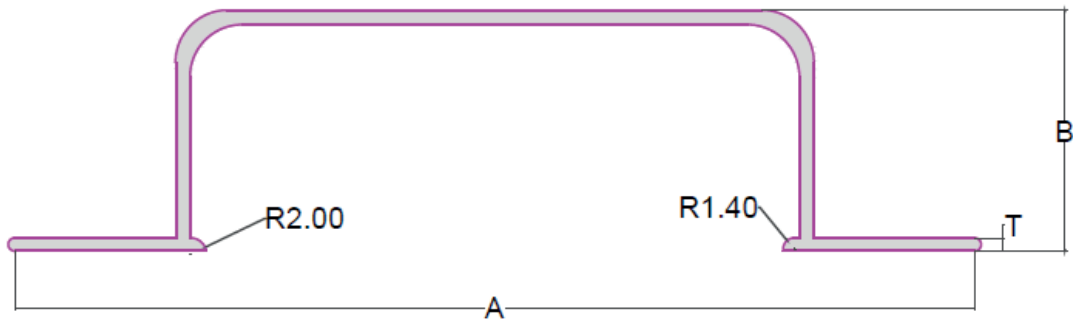

SL NO.	SECTION NO	A	B	T	WEIGHT RANGE KG/12'
1	1474	119.90	30.00	1.60	3.000-3.300

6" C HANDLE

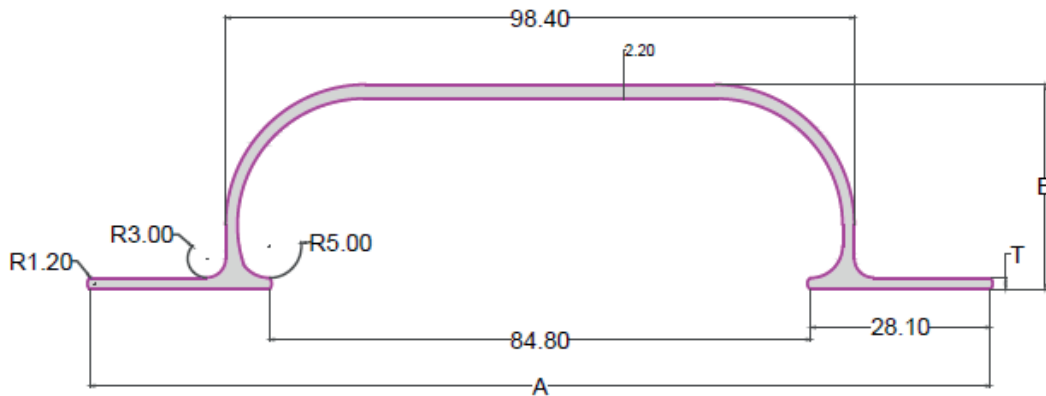

SL NO.	SECTION NO	A	B	T	WEIGHT RANGE KG/12'
1	1475	141.00	33.20	1.80	2.800-3.000
2	1476	141.00	33.20	2.10	4.300-4.600
3	1477	141.00	33.20	2.20	4.600-4.800

6" D HANDLE



SL NO.	SECTION NO	A	B	T	WEIGHT RANGE KG/12'
1	1478	142.30	30.00	2.00	4.000-4.300
2	1479	144.60	30.00	2.30	5.000-5.300
3	1480	146.20	30.00	2.60	7.000-7.300

TOWER BOLT

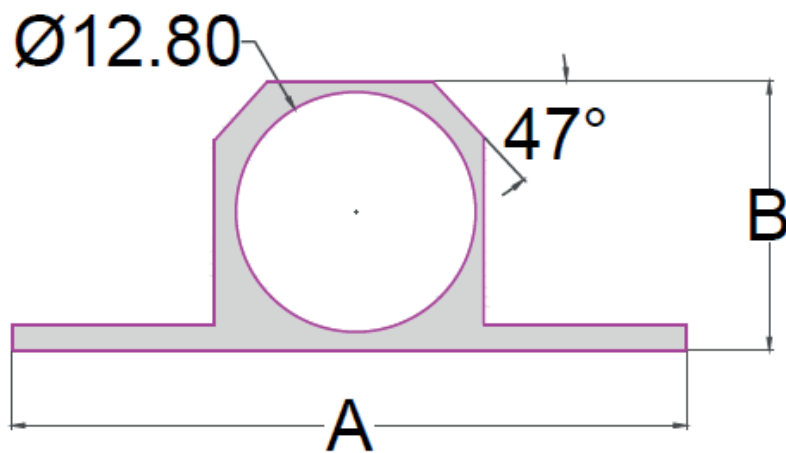

SL NO.	SECTION NO	A	B	WEIGHT RANGE KG/12'
1	1481	36.10	14.40	0.900-1.000

TOWER BOLT

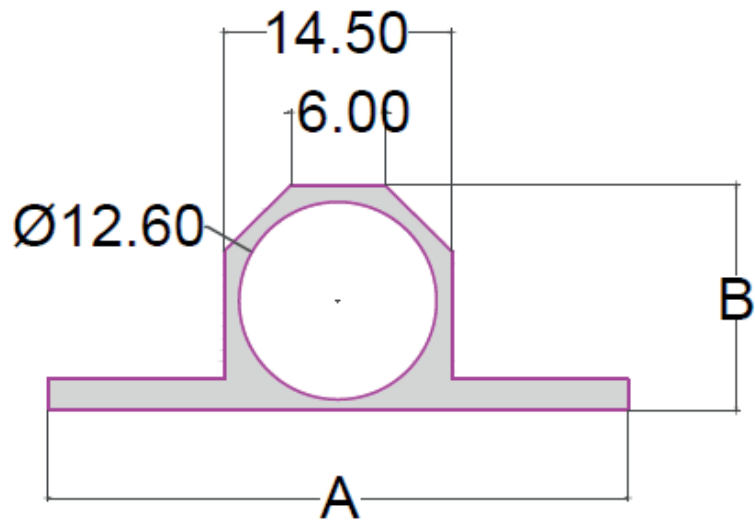

SL NO.	SECTION NO	A	B	WEIGHT RANGE KG/12'
1	1482	37.00	14.35	1.000-1.200

TOWER BOLT

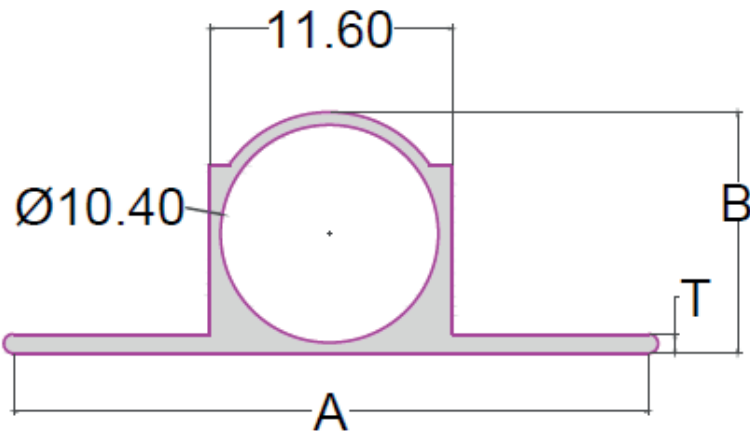

SL NO.	SECTION NO	A	B	T	WEIGHT RANGE KG/12'
1	1483	30.30	11.50	0.90	0.600-0.700

TOWER BOLT

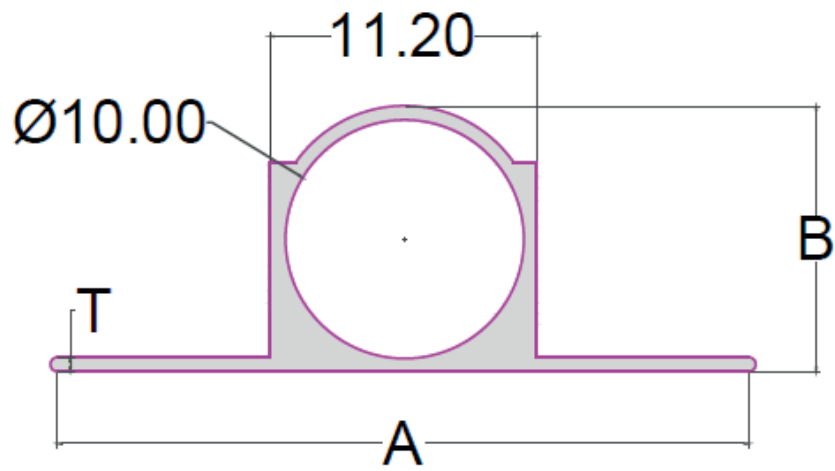

SL NO.	SECTION NO	A	B	T	WEIGHT RANGE KG/12'
1	1484	29.00	11.15	0.60	0.500-0.600

DOMAL SERIES

DIE NO 903

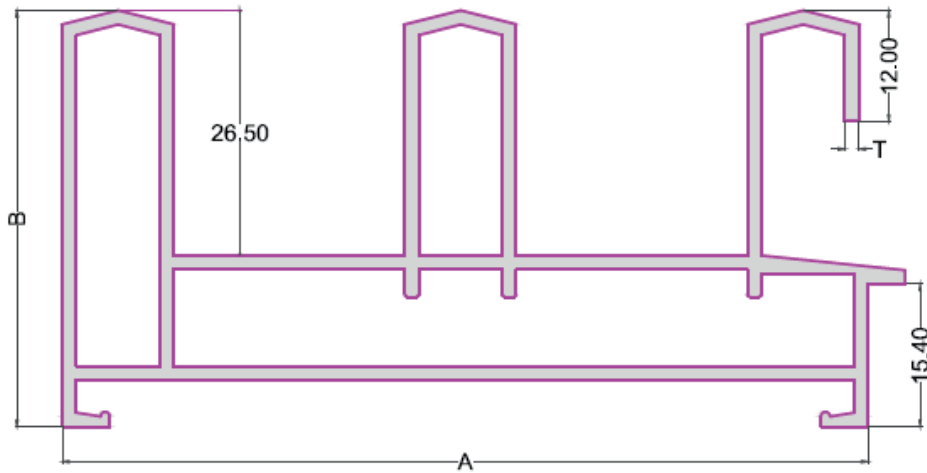

SL NO.	SECTION NO	A	B	T	WEIGHT RANGE KG/12'
1	1485	91.00	45.00	1.50	5.600-5.900
2	1486	91.00	45.00	1.70	6.300-6.600

DIE NO 905

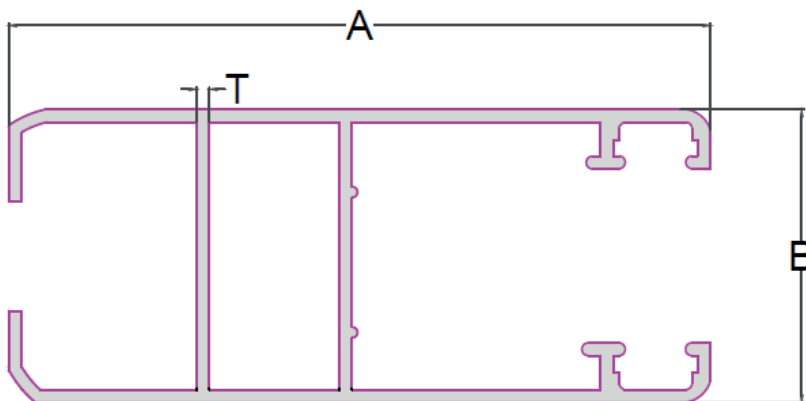

SL NO.	SECTION NO	A	B	T	WEIGHT RANGE KG/12'
1	1487	65.00	27.20	1.20	3.000-3.300

DIE NO 5005

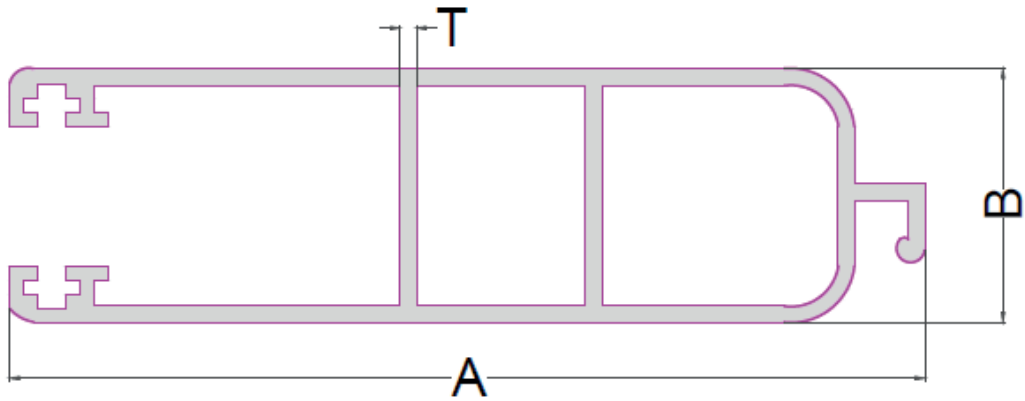

SL NO.	SECTION NO	A	B	T	WEIGHT RANGE KG/12'
1	1488	65.00	18.00	1.15	2.200-2.400

DIE NO 5010

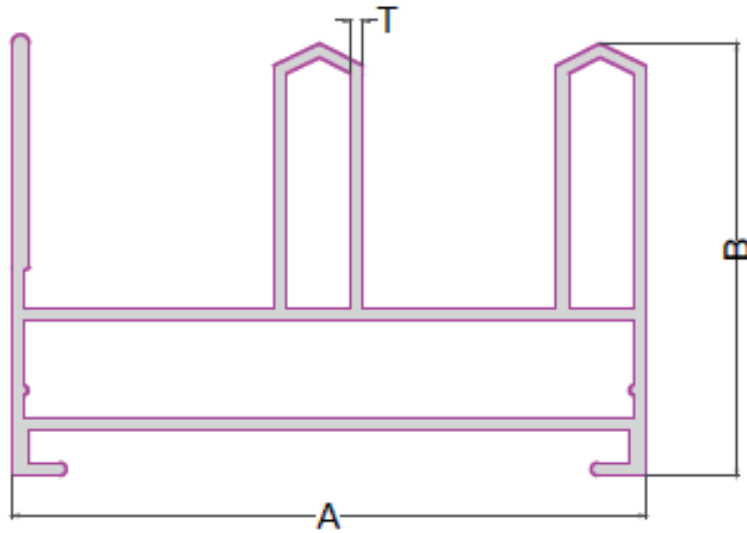

SL NO.	SECTION NO	A	B	T	WEIGHT RANGE KG/12'
1	1489	66.00	45.00	1.30	4.400-4.600

DIE NO 5290

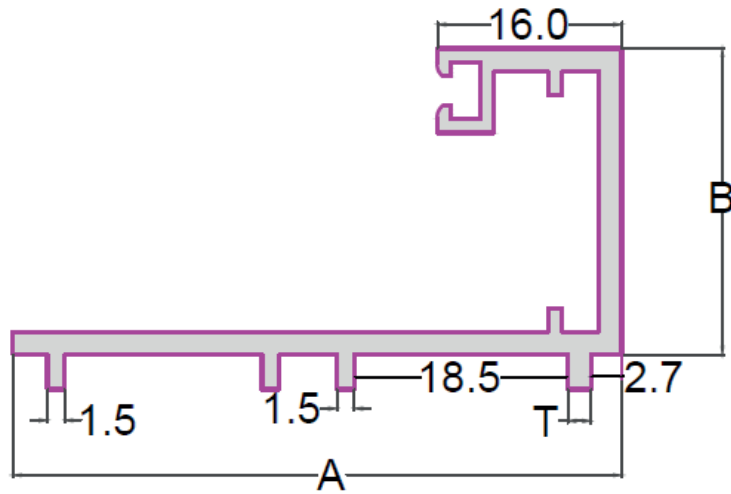

SL NO.	SECTION NO	A	B	T	WEIGHT RANGE KG/12'
1	1490	52.80	23.50	2.00	1.900-2.100

DIE NO 5291

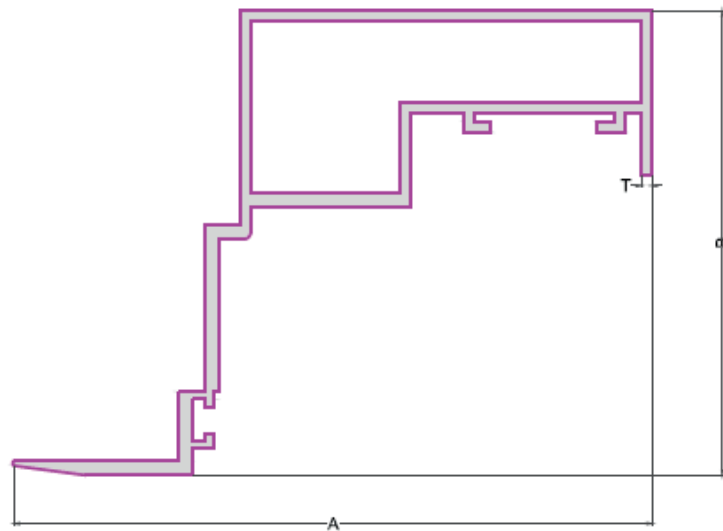

SL NO.	SECTION NO	A	B	T	WEIGHT RANGE KG/12'
1	1491	90.40	66.00	2.00	4.200-4.500

DIE NO 5529

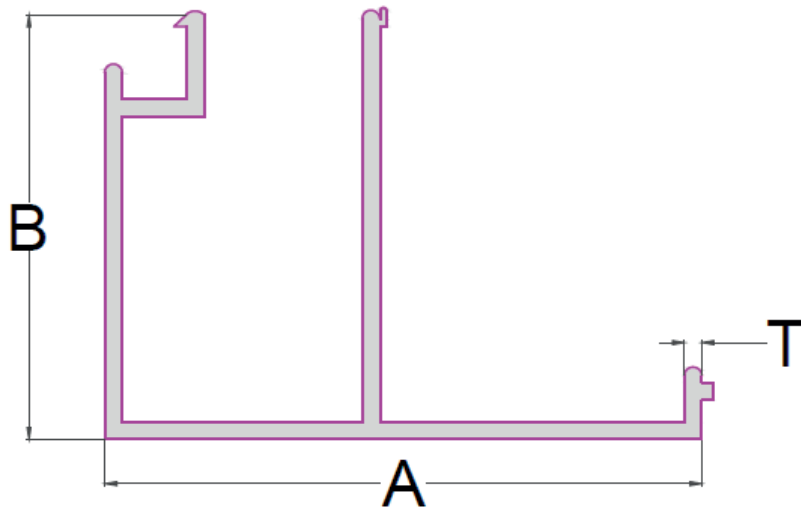

SL NO.	SECTION NO	A	B	T	WEIGHT RANGE KG/12'
1	1492	34.4	24.50	1.00	0.800-1.000

DIE NO 5530

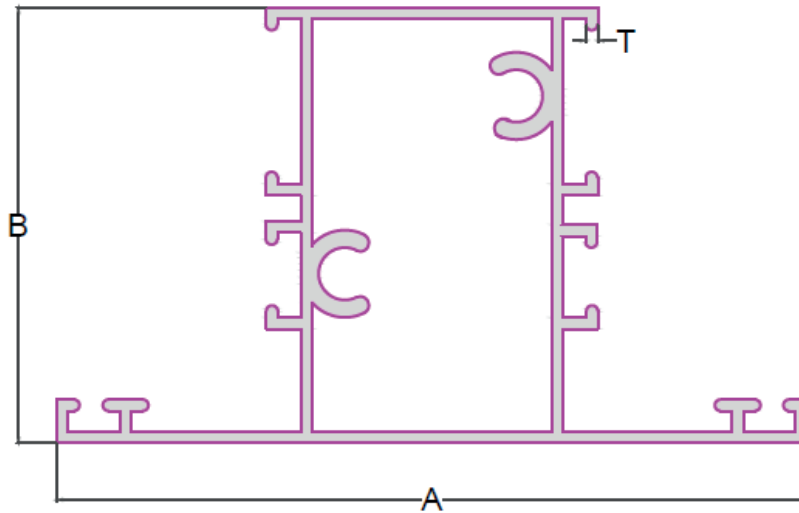

SL NO.	SECTION NO	A	B	T	WEIGHT RANGE KG/12'
1	1493	86.00	50.00	1.30	3.500-3.700

DIE NO 5531

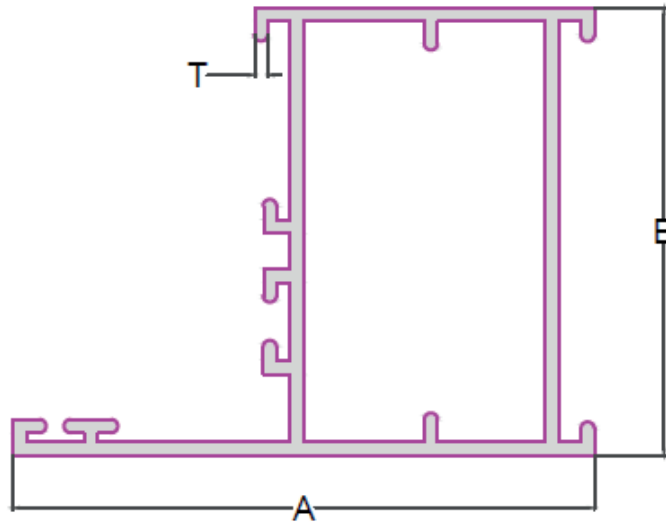

SL NO.	SECTION NO	A	B	T	WEIGHT RANGE KG/12'
1	1494	65.00	50.00	1.50	3.200-3.400

DIE NO 5532

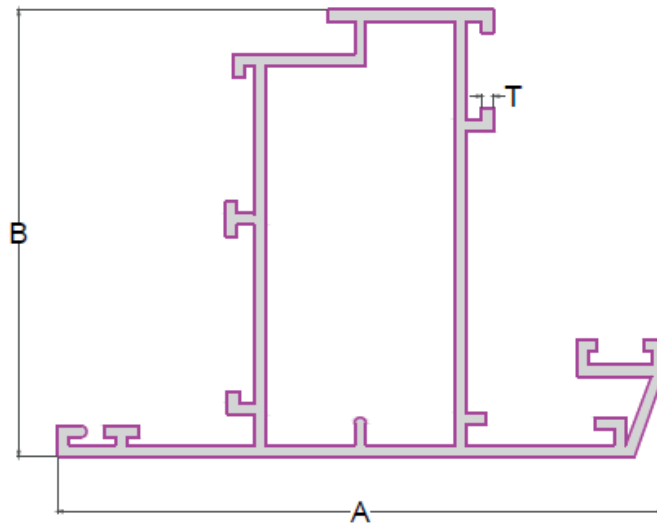

SL NO.	SECTION NO	A	B	T	WEIGHT RANGE KG/12'
1	1495	78.50	58.00	1.50	3.500-3.700

DIE NO 8072

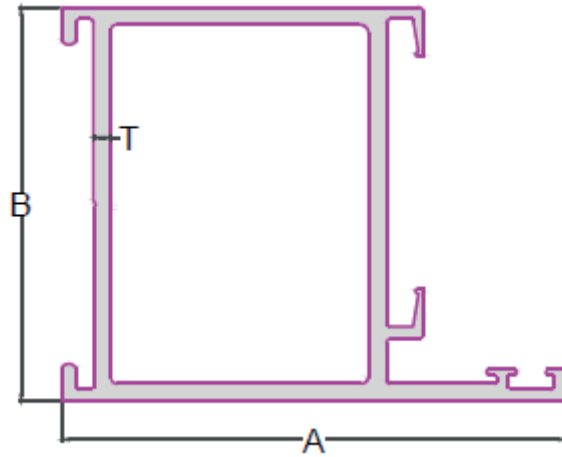

SL NO.	SECTION NO	A	B	T	WEIGHT RANGE KG/12'
1	1496	51.00	40.00	1.80	3.000-3.200

DIE NO 8073

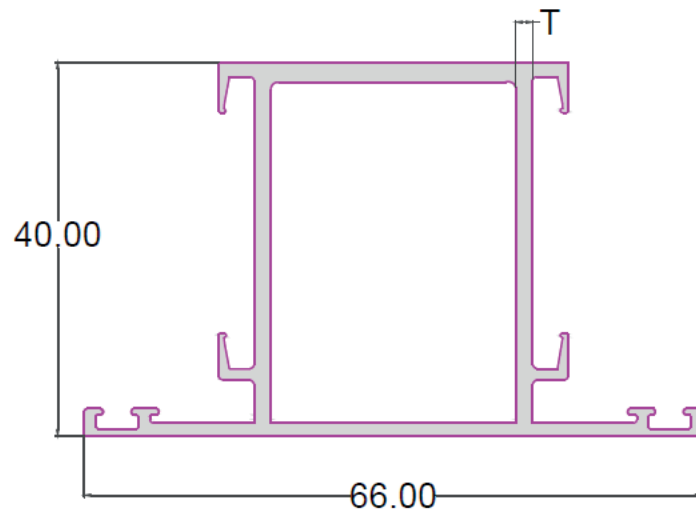

SL NO.	SECTION NO	T	WEIGHT RANGE KG/12'
1	1497	1.80	3.300-3.500
2	1498	1.20	2.500-2.700

DIE NO 8078

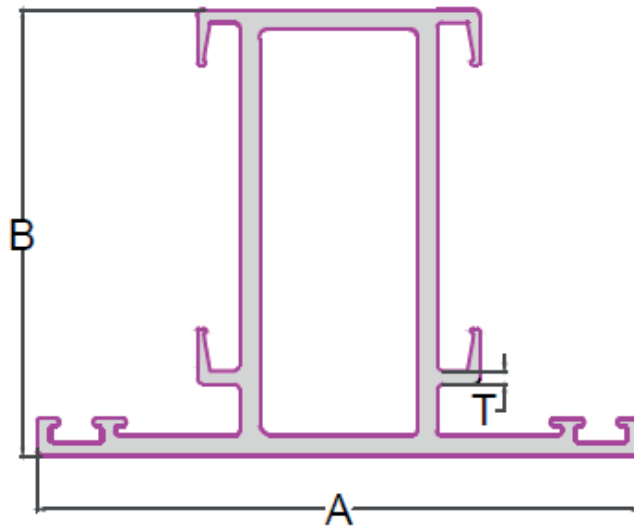

SL NO.	SECTION NO	A	B	T	WEIGHT RANGE KG/12'
1	1499	54.00	40.00	1.20	3.000-3.200

DIE NO 8078-A

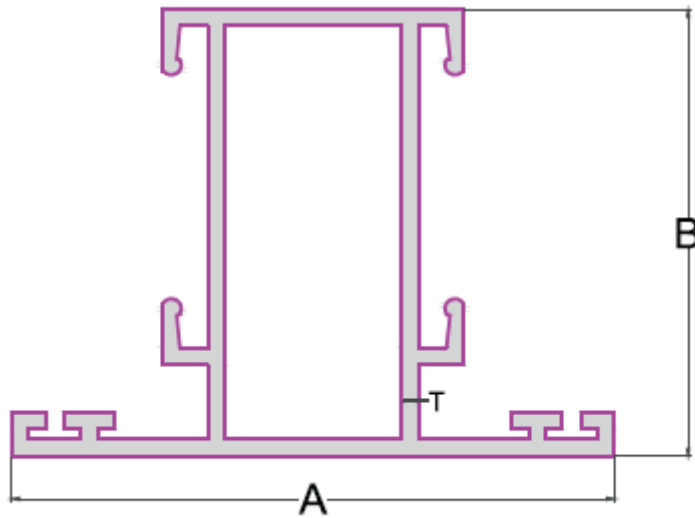

SL NO.	SECTION NO	A	B	T	WEIGHT RANGE KG/12'
1	1500	54.00	40.00	1.50	2.600-2.900

DIE NO 8079

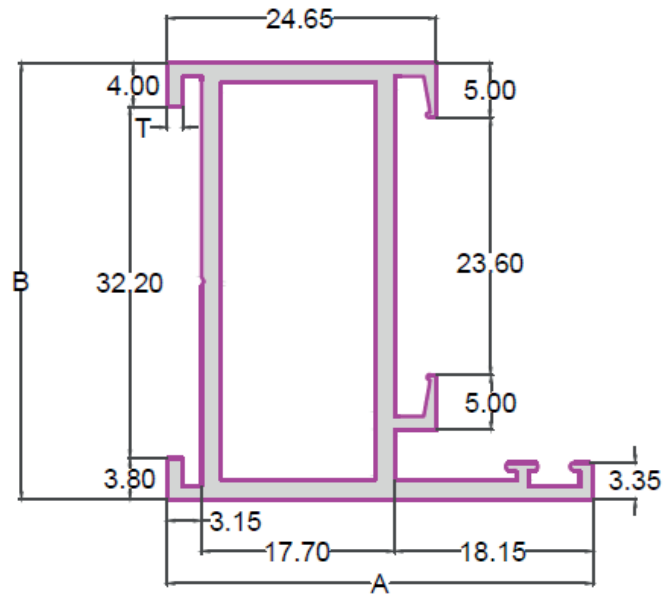

SL NO.	SECTION NO	A	B	T	WEIGHT RANGE KG/12'
1	1501	39.00	40.00	1.40	2.400-2.600

DIE NO 8079-A

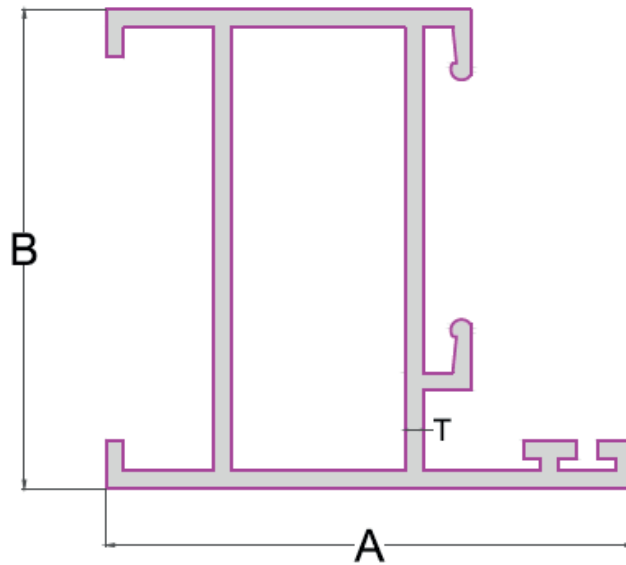

SL NO.	SECTION NO	A	B	T	WEIGHT RANGE KG/12'
1	1502	40.00	44.00	1.50	2.500-2.800

DIE NO 8082

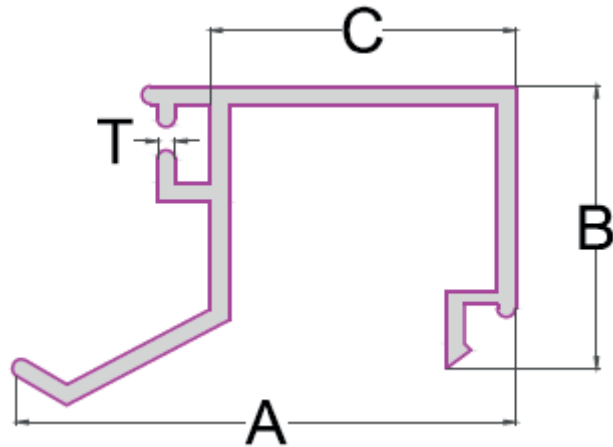

SL NO.	SECTION NO	A	B	C	T	WEIGHT RANGE KG/12'
1	1503	32.00	17.00	22.00	1.10	0.800-0.900
2	1504	32.00	17.00	26.00	1.10	0.800-0.900

DIE NO 8088

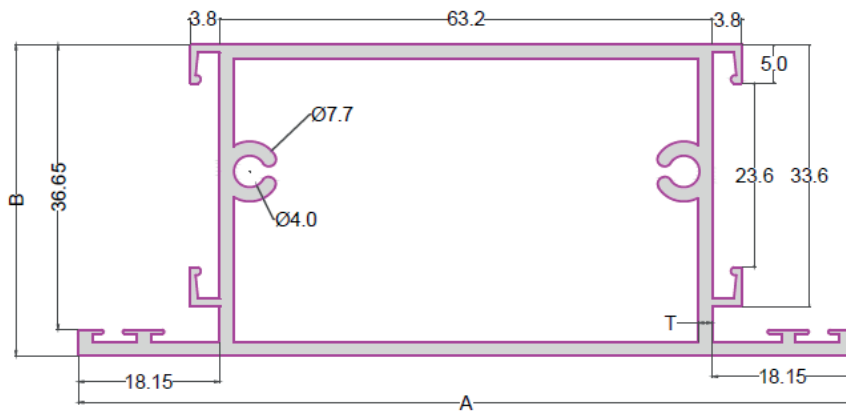

SL NO.	SECTION NO	A	B	T	WEIGHT RANGE KG/12'
1	1505	99.50	40.00	1.80	4.900-5.100

DIE NO 8090

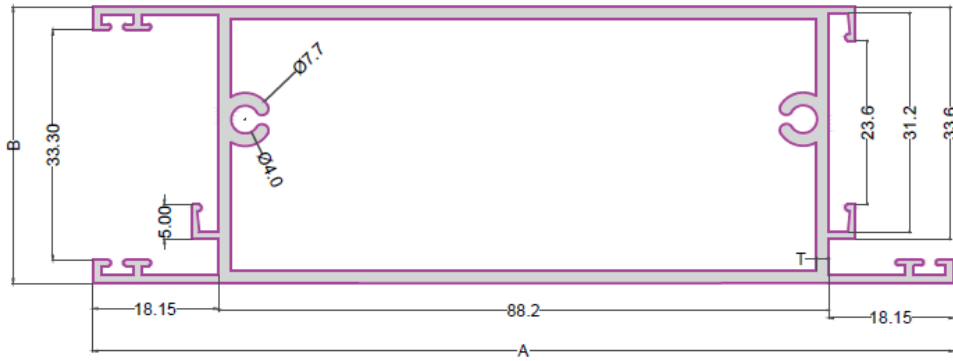

SL NO.	SECTION NO	A	B	T	WEIGHT RANGE KG/12'
1	1506	124.50	40.00	1.80	5.900-6.100

DIE NO 9004

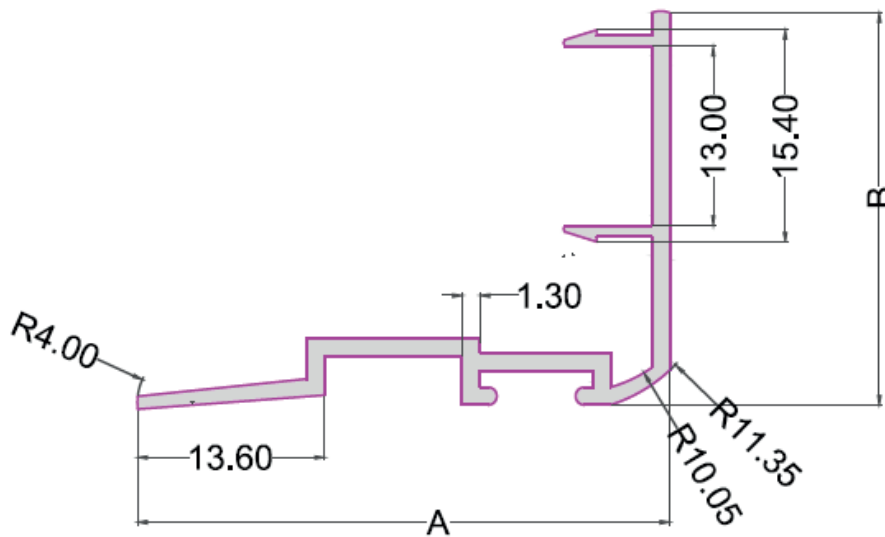

SL NO.	SECTION NO	A	B	T	WEIGHT RANGE KG/12'
1	1507	38.70	28.50	1.30	0.900-1.100

DIE NO 9005

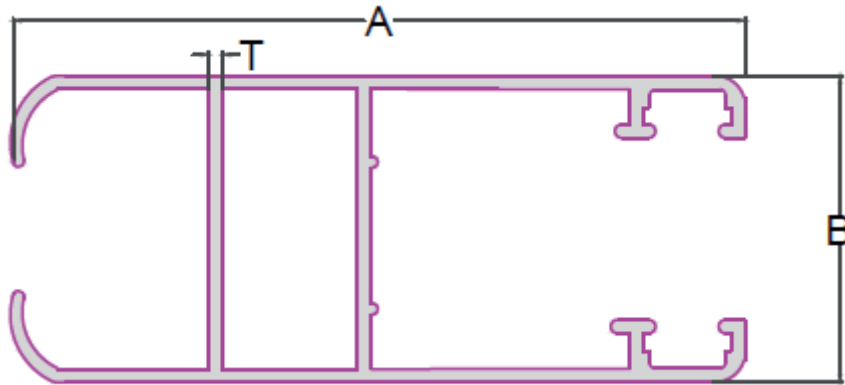

SL NO.	SECTION NO	A	B	T	WEIGHT RANGE KG/12'
1	1508	65.00	27.1	0.70	2.500-2.700
2	1509	65.00	27.1	0.90	3.000-3.300
3	1510	65.00	27.1	0.95	3.300-3.500

DIE NO 9005-A

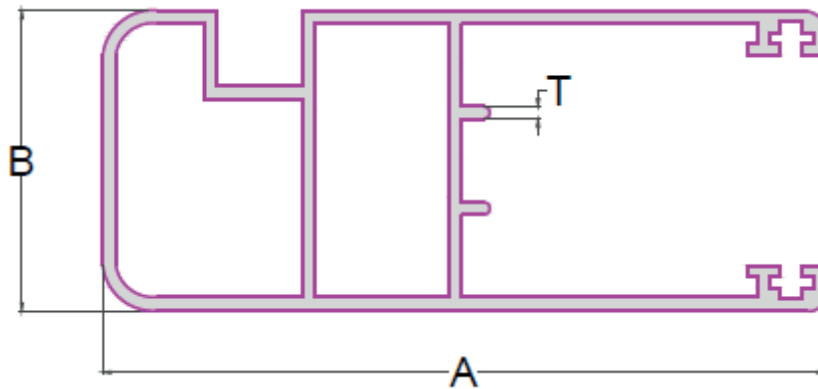

SL NO.	SECTION NO	A	B	T	WEIGHT RANGE KG/12'
1	1511	65.00	27.00	1.15	2.700-2.900

DIE NO 9006

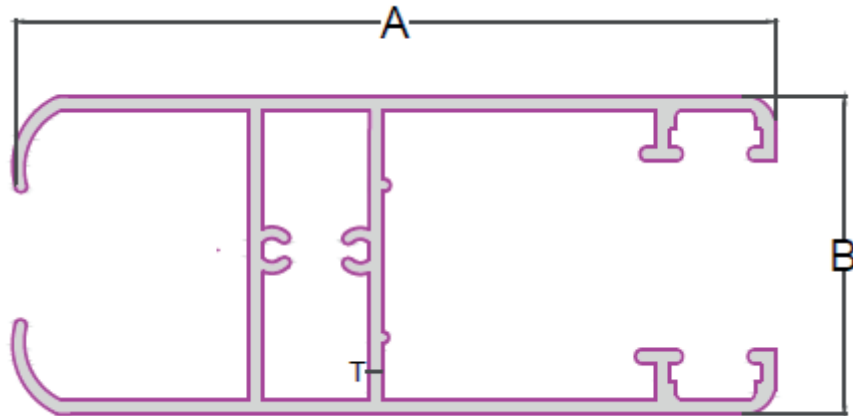

SL NO.	SECTION NO	A	B	T	WEIGHT RANGE KG/12'
1	1512	65.00	27.20	1.20	2.900-3.100

DIE NO 9007

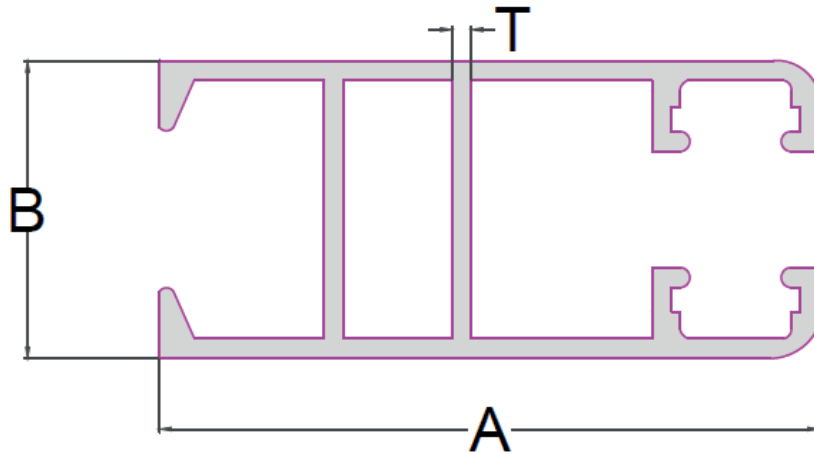

SL NO.	SECTION NO	A	B	T	WEIGHT RANGE KG/12'
1	1513	40.00	18.00	1.00	1.700-1.900

DIE NO 9009

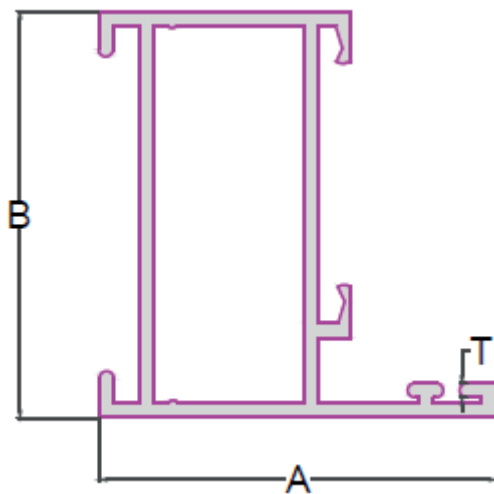

SL NO.	SECTION NO	A	B	T	WEIGHT RANGE KG/12'
1	1514	39.00	40.00	0.98	1.800-2.000

DIE NO 9010

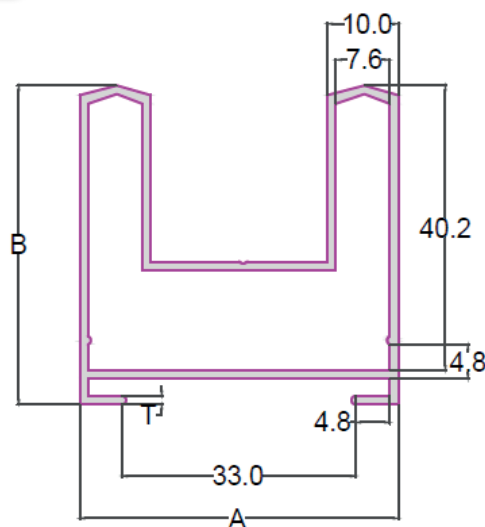

SL NO.	SECTION NO	A	B	T	WEIGHT RANGE KG/12'
1	1515	45.00	45.00	0.98	2.700-2.900
2	1516	45.00	45.00	1.30	3.500-3.700

DIE NO 9011

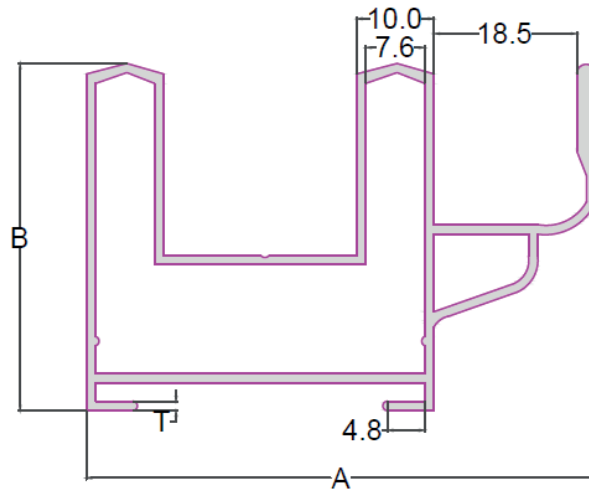

SL NO.	SECTION NO	A	B	T	WEIGHT RANGE KG/12'
1	1517	66.00	45.00	1.10	3.800-4.000

DIE NO 9017

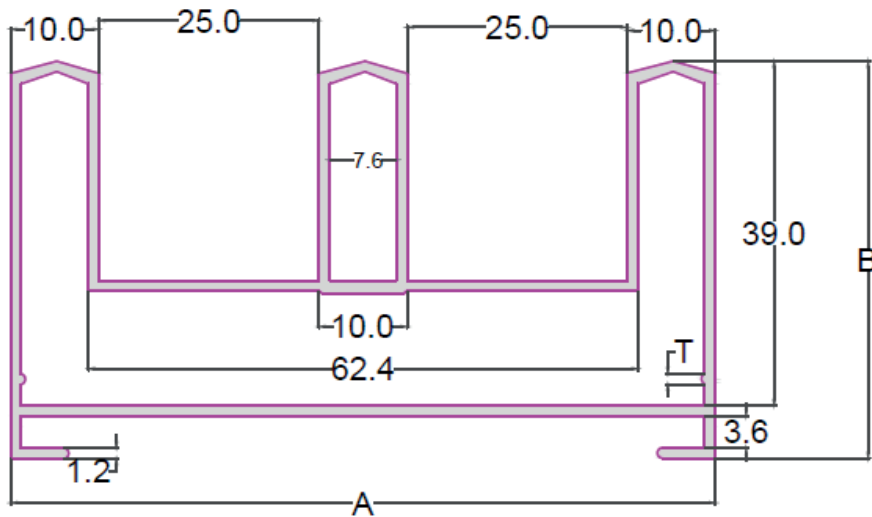

SL NO.	SECTION NO	A	B	T	WEIGHT RANGE KG/12'
1	1518	80.00	45.00	1.07	4.500-4.800
2	1519	80.00	45.00	1.15	4.900-5.100

DIE NO 9025

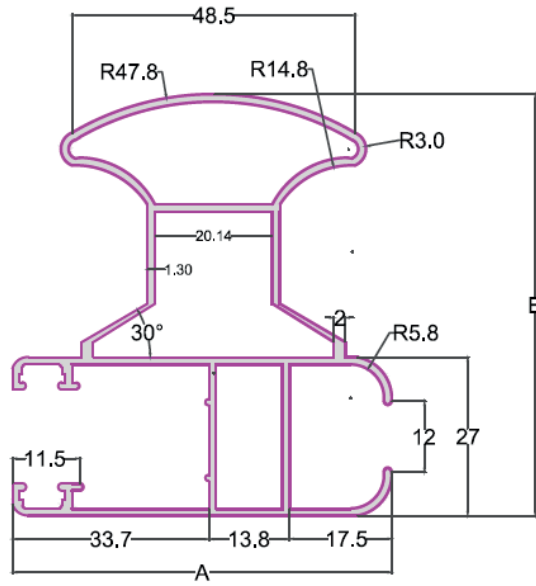

SL NO.	SECTION NO	A	B	WEIGHT RANGE KG/12'
1	1520	65.00	69.5	4.800-5.000

DIE NO 9027

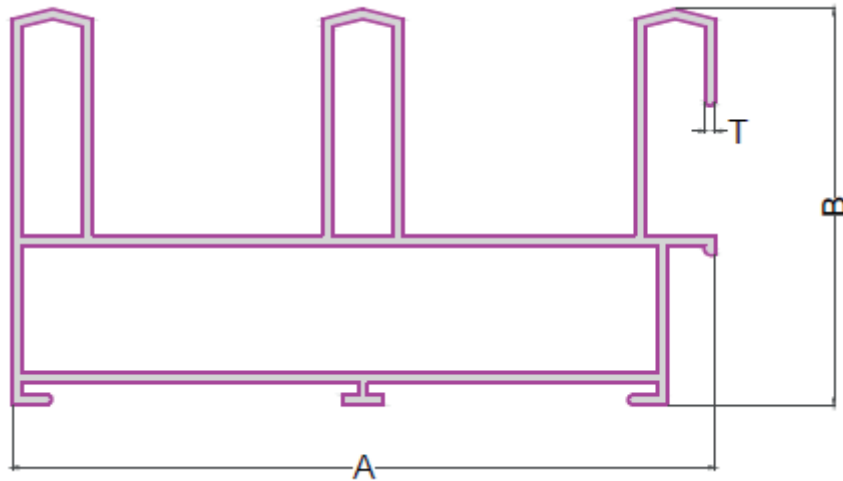

SL NO.	SECTION NO	A	B	T	WEIGHT RANGE KG/12'
1	1521	80.00	45.00	1.50	4.700-4.900

DIE NO 9037

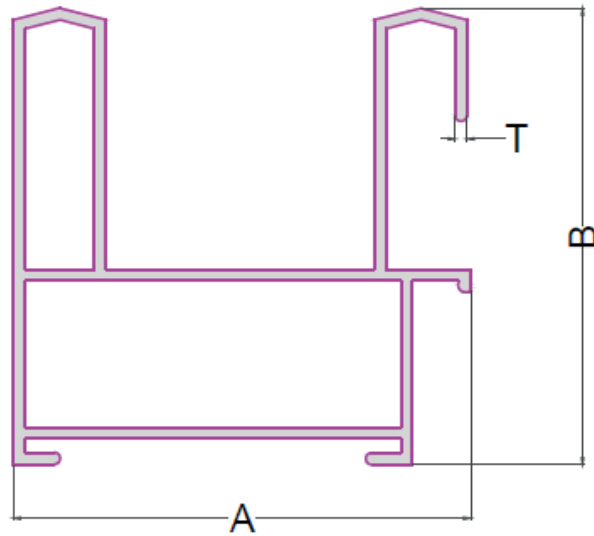

SL NO.	SECTION NO	A	B	T	WEIGHT RANGE KG/12'
1	1522	45.00	45.00	1.15	2.300-2.500
2	1523	45.00	45.00	1.30	2.700-2.900

DIE NO 9038

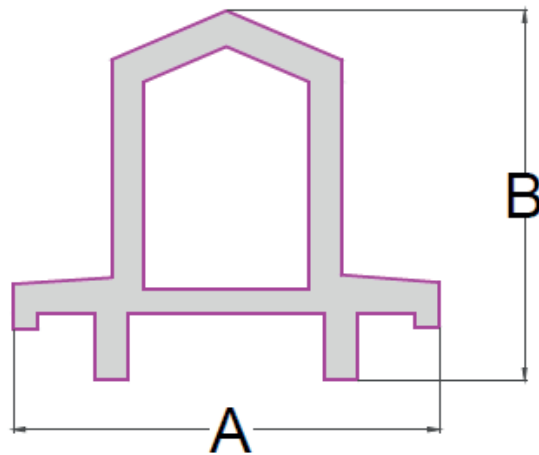

SL NO.	SECTION NO	A	B	WEIGHT RANGE KG/12'
1	1524	26.00	22.00	0.900-1.000

DIE NO 9041

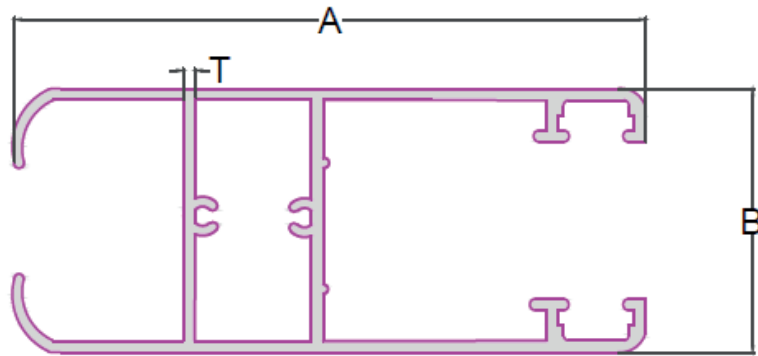

SL NO.	SECTION NO	A	B	T	WEIGHT RANGE KG/12'
1	1525	65.00	27.20	1.20	2.700-3.000

DIE NO 9044

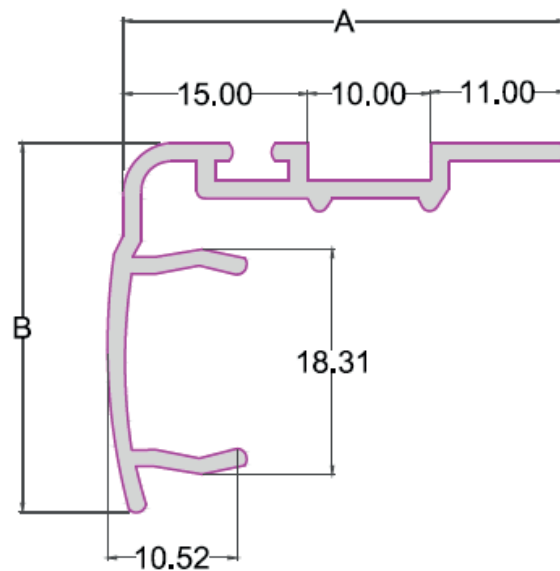

SL NO.	SECTION NO	A	B	WEIGHT RANGE KG/12'
1	1526	36.00	30.00	0.900-1.100

DIE NO 9052

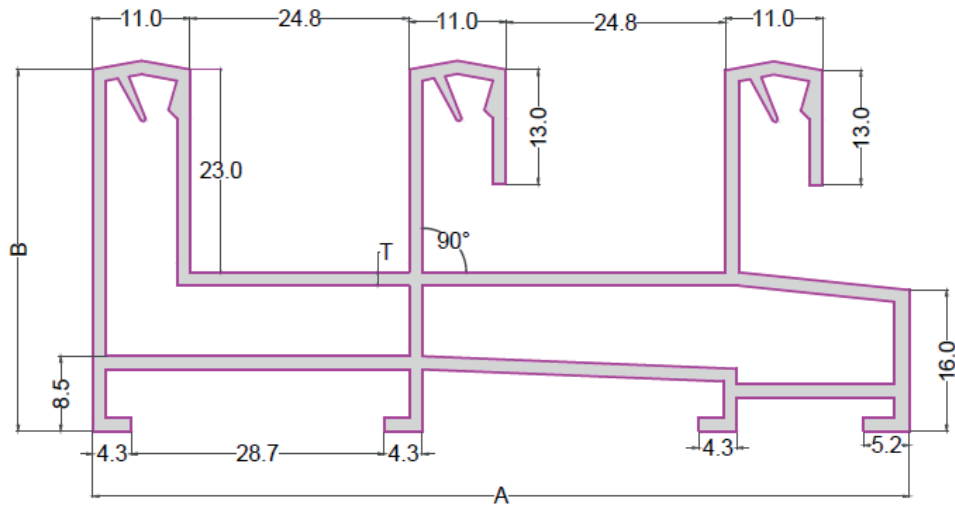

SL NO.	SECTION NO	A	B	T	WEIGHT RANGE KG/12'
1	1527	92.5	41.00	1.40	5.000-5.300
2	1528	92.5	41.00	1.60	6.300-6.500

DIE NO 9053

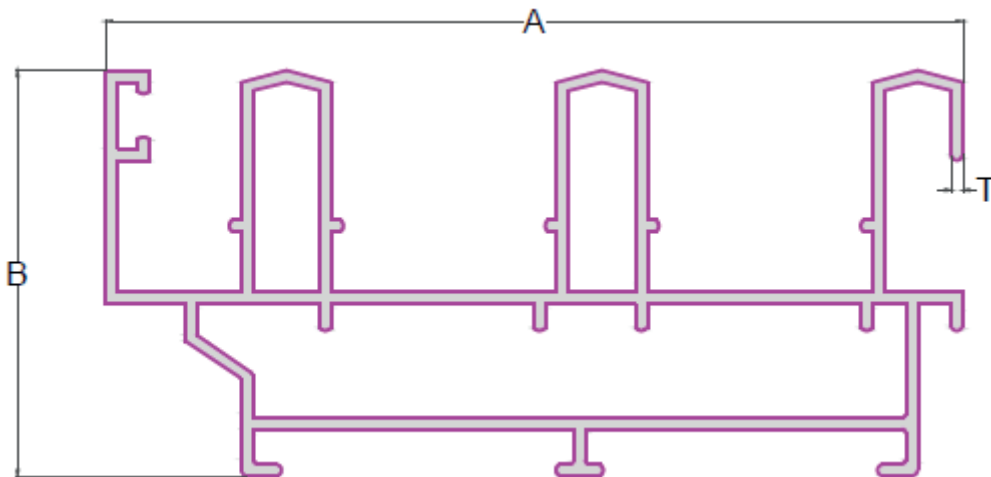

SL NO.	SECTION NO	A	B	T	WEIGHT RANGE KG/12'
1	1529	95.00	45.00	1.30	5.700-6.000

DIE NO 9053-A

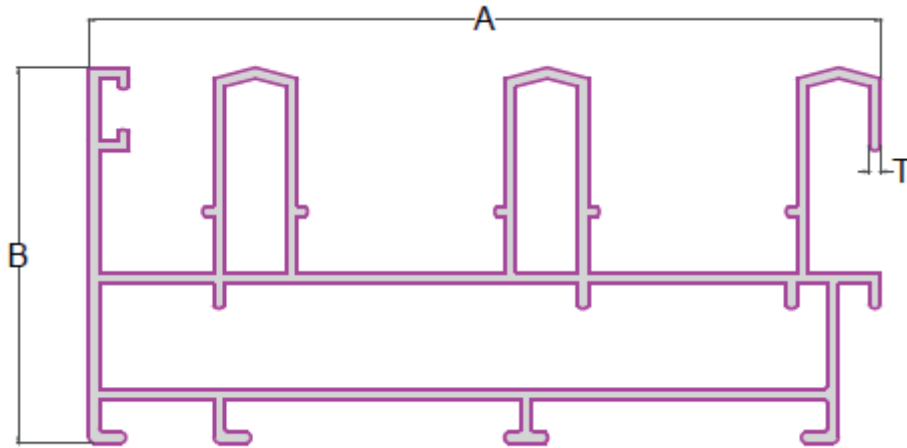

SL NO.	SECTION NO	A	B	T	WEIGHT RANGE KG/12'
1	1530	95.00	45.00	1.30	7.800-9.100

DIE NO 9055

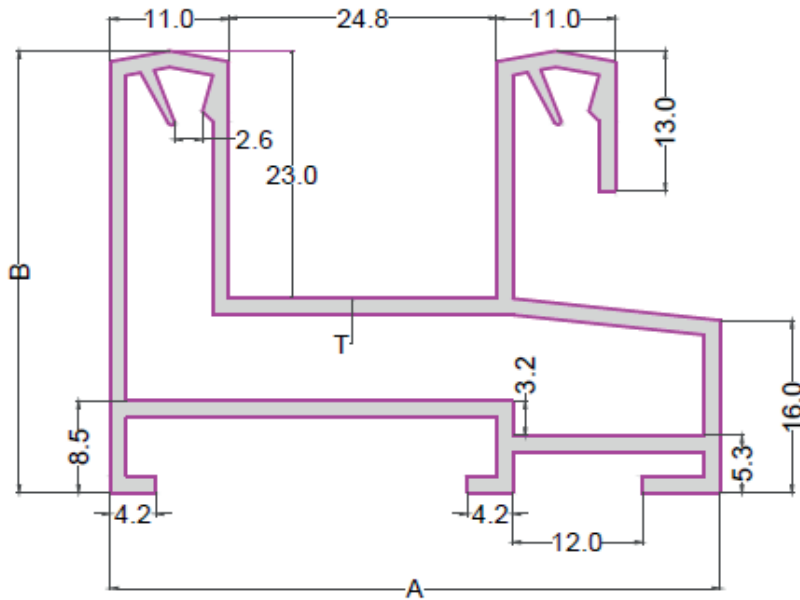

SL NO.	SECTION NO	A	B	T	WEIGHT RANGE KG/12'
1	1531	56.5	41.00	1.45	2.800-2.900

DIE NO 9057

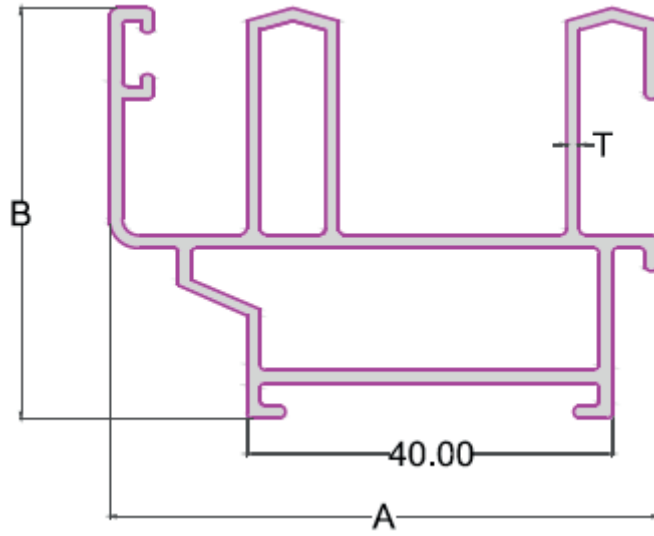

SL NO.	SECTION NO	A	B	T	WEIGHT RANGE KG/12'
1	1532	60.00	49.00	0.98	3.300-3.500

DIE NO 9067

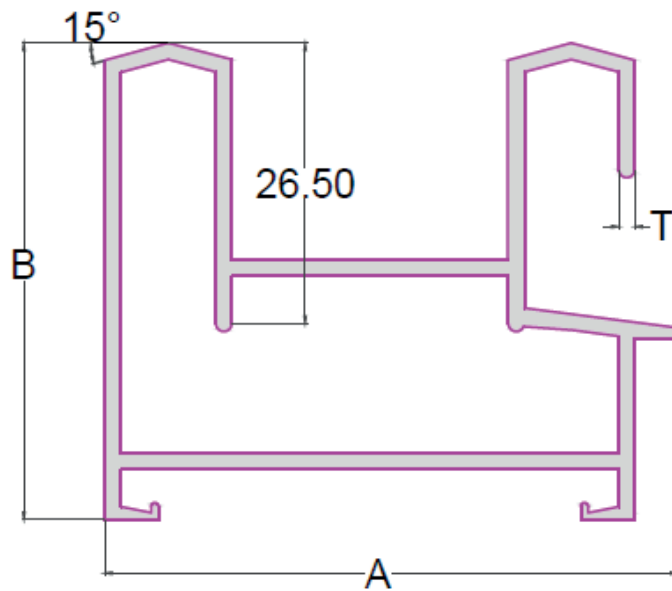

SL NO.	SECTION NO	A	B	T	WEIGHT RANGE KG/12'
1	1533	54.00	45.00	1.50	2.700-2.900

DIE NO 9201

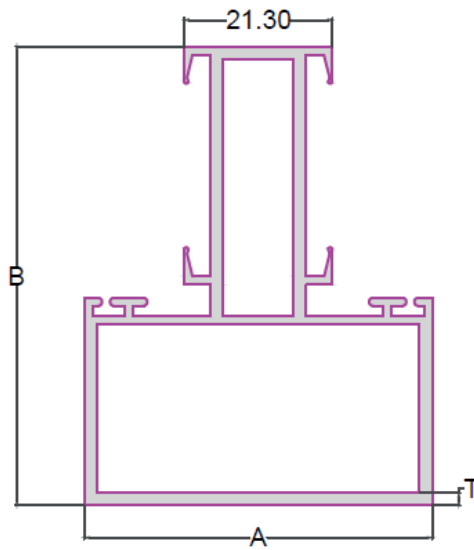

SL NO.	SECTION NO	A	B	T	WEIGHT RANGE KG/12'
1	1534	50.00	66.00	1.80	3.400-3.600

DIE NO 9204

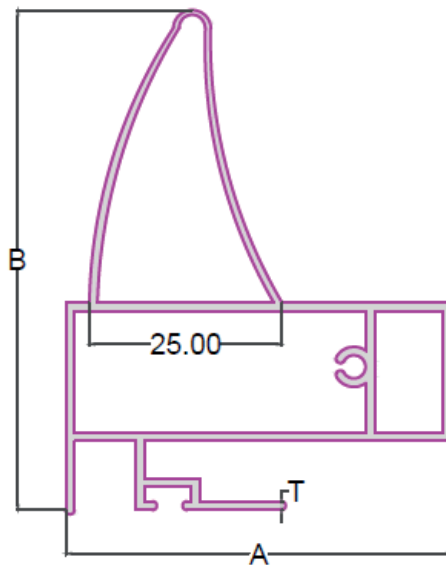

SL NO.	SECTION NO	A	B	T	WEIGHT RANGE KG/12'
1	1535	50.00	65.00	1.10	2.800-3.000

DIE NO 9205

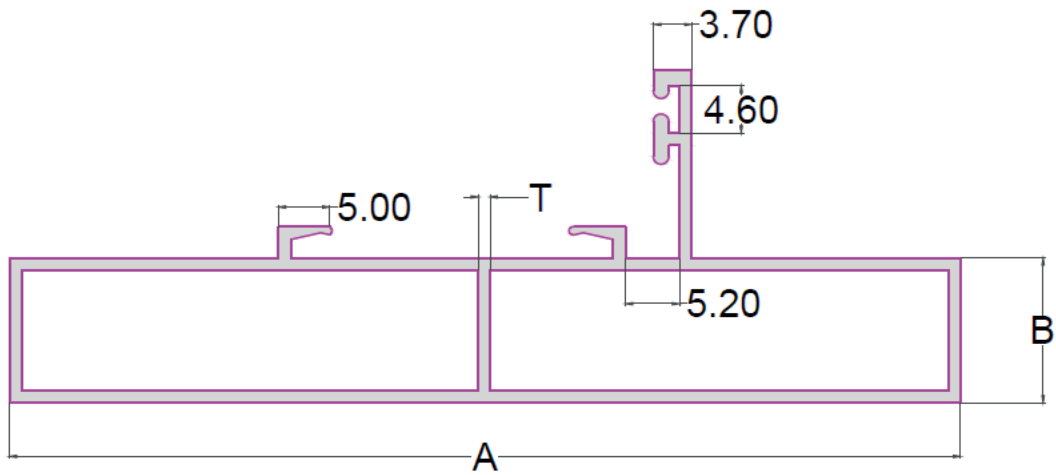

SL NO.	SECTION NO	A	B	T	WEIGHT RANGE KG/12'
1	1536	92.00	32.15	1.20	2.900-3.100

DIE NO 9206

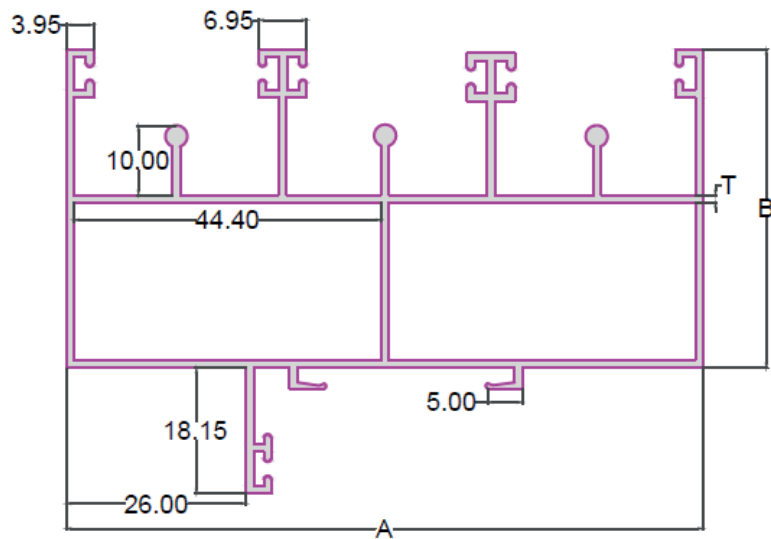

SL NO.	SECTION NO	A	B	T	WEIGHT RANGE KG/12'
1	1537	92.00	46.00	1.10	5.000-5.200

DIE NO 9801

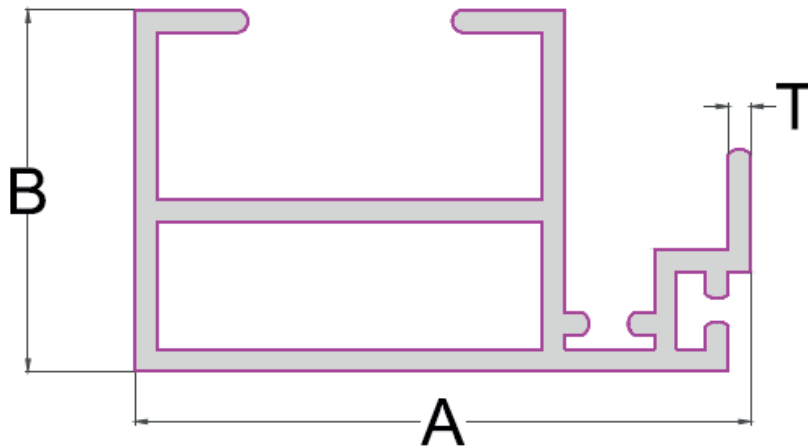

SL NO.	SECTION NO	A	B	T	WEIGHT RANGE KG/12'
1	1538	35.8	21.00	1.30	1.500-1.700

DIE NO 9803

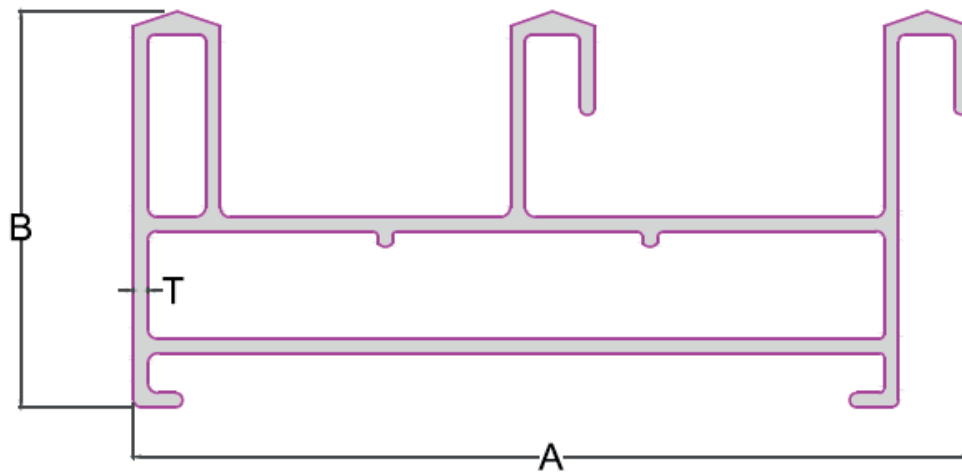

SL NO.	SECTION NO	A	B	T	WEIGHT RANGE KG/12'
1	1539	84.5	40.00	1.45	4.500-4.700

DIE NO 9804

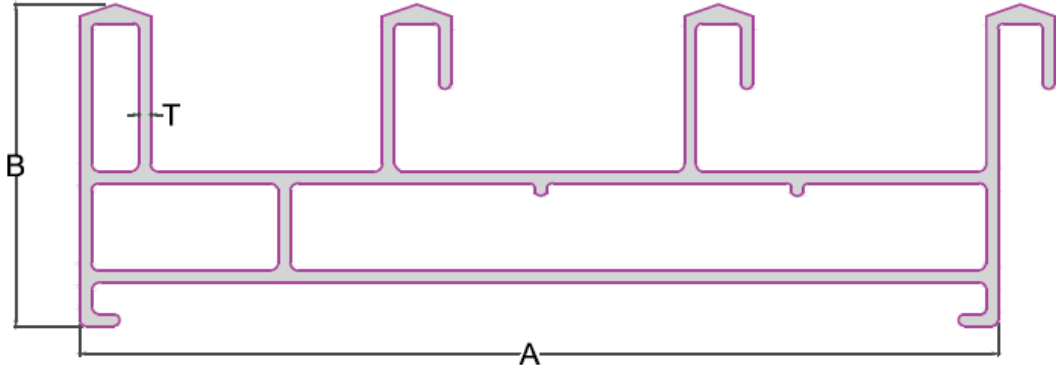

SL NO.	SECTION NO	A	B	T	WEIGHT RANGE KG/12'
1	1540	114.35	40.00	1.50	6.500-6.700

DIE NO 9805

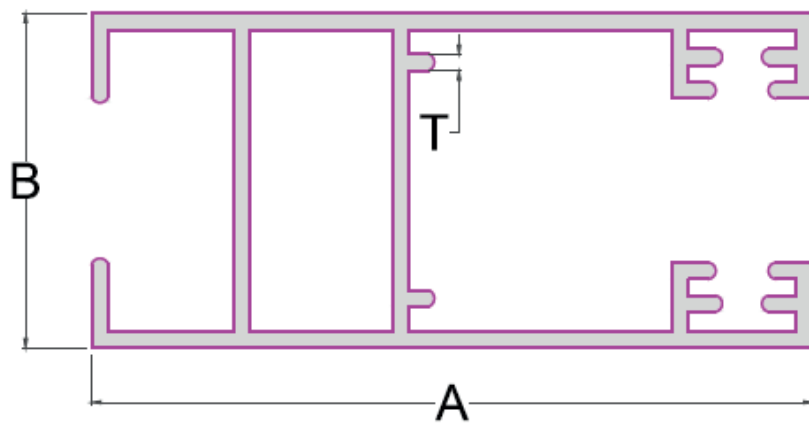

SL NO.	SECTION NO	A	B	T	WEIGHT RANGE KG/12'
1	1541	54.60	25.30	1.25	2.400-2.600

DIE NO 9807

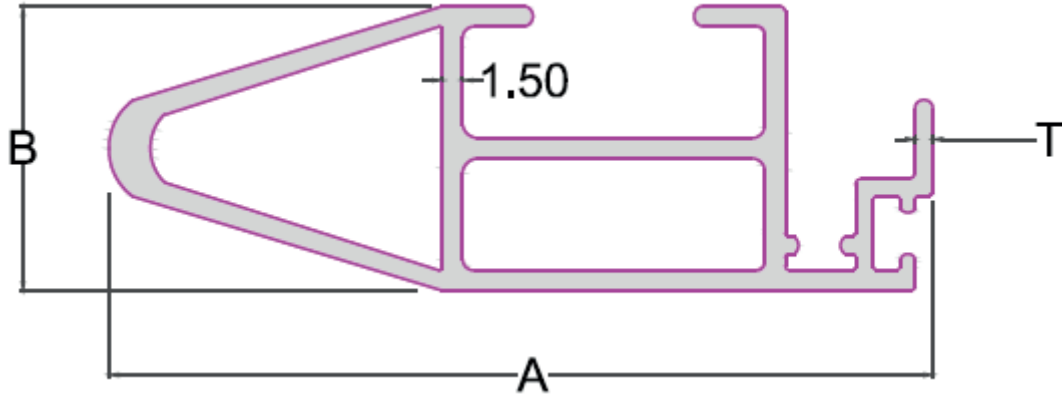

SL NO.	SECTION NO	A	B	T	WEIGHT RANGE KG/12'
1	1542	60.80	21.00	1.30	2.700-2.900

DOMAL GLASS MEETING

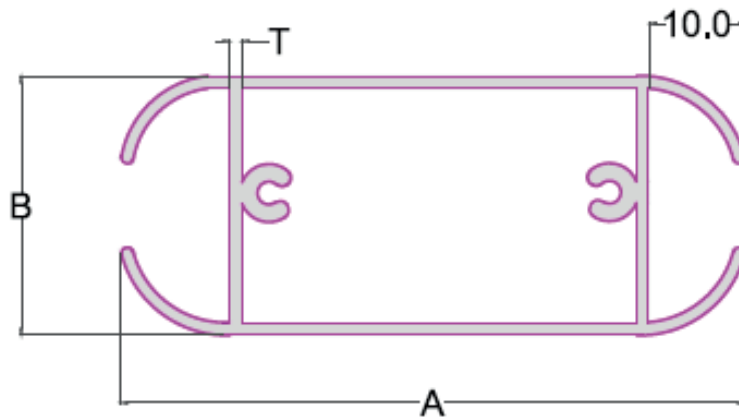

SL NO.	SECTION NO	A	B	T	WEIGHT RANGE KG/12'
1	1543	65.00	27.00	1.44	2.500-2.700

KC-003

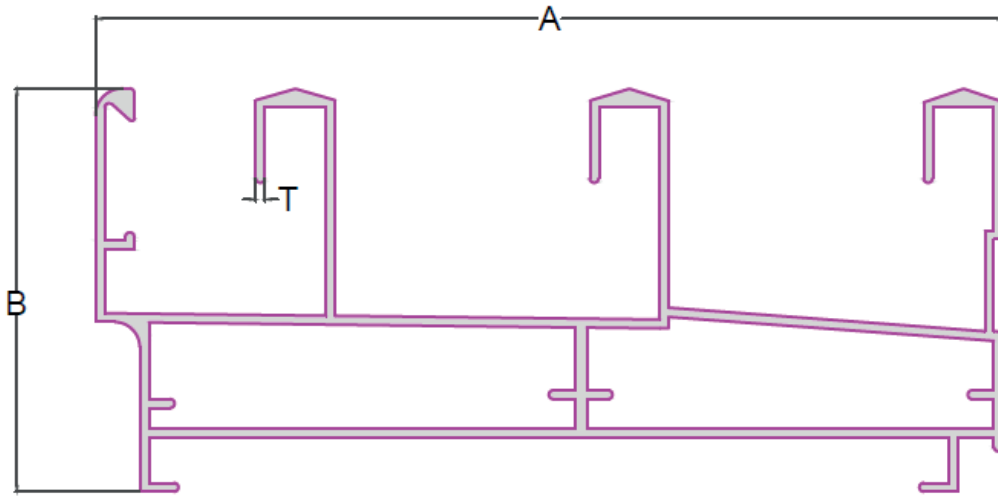

SL NO.	SECTION NO	A	B	T	WEIGHT RANGE KG/12'
1	1544	100.90	44.90	1.10	4.300-4.500

SVL SERIES

SVL 1



SL NO.	SECTION NO	A	T	WEIGHT RANGE KG/12'
1	1545	95.00	1.99	5.200-5.500

SVL 2



SL NO.	SECTION NO	A	B	T	WEIGHT RANGE KG/12'
1	1546	68.20	23.90	1.60	1.900-2.200

SVL 3

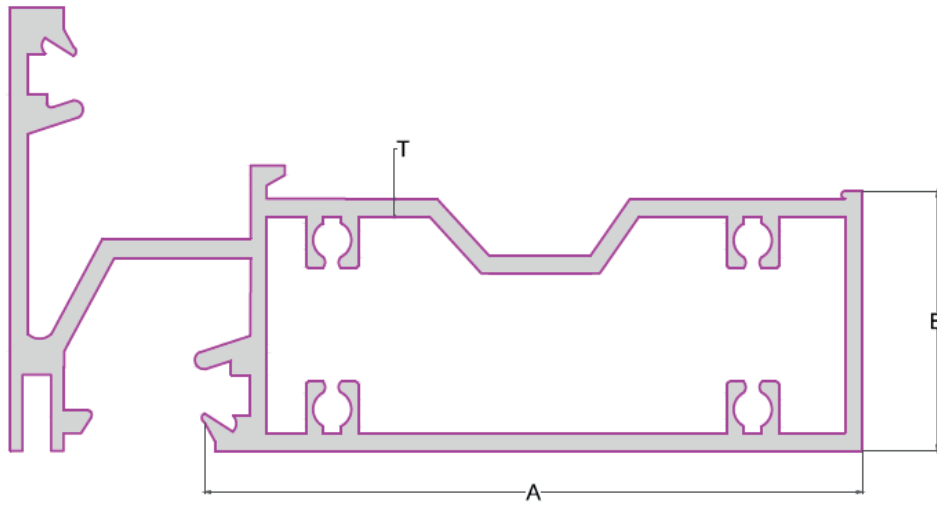

SL NO.	SECTION NO	A	B	T	WEIGHT RANGE KG/12'
1	1547	75.40	29.30	2.00	7.000-7.300

SVL 4

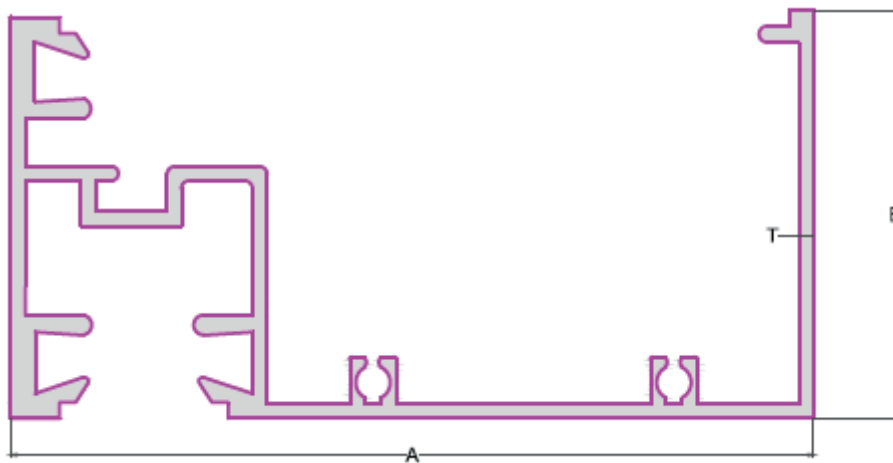

SL NO.	SECTION NO	A	B	T	WEIGHT RANGE KG/12'
1	1548	100.06	50.80	1.80	5.300-5.600

SVL 5

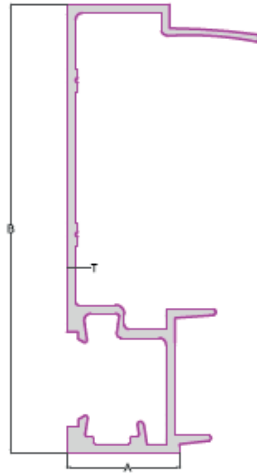

SL NO.	SECTION NO	A	B	T	WEIGHT RANGE KG/12'
1	1549	25.00	100.00	1.80	4.500-4.800

SVL 6

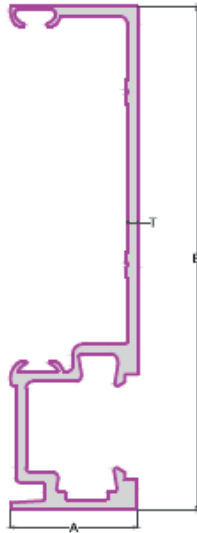

SL NO.	SECTION NO	A	B	T	WEIGHT RANGE KG/12'
1	1550	25.00	100.00	2.00	3.700-4.000

HOLLOW SERIES

HOLLOW-2 TRACK TOP

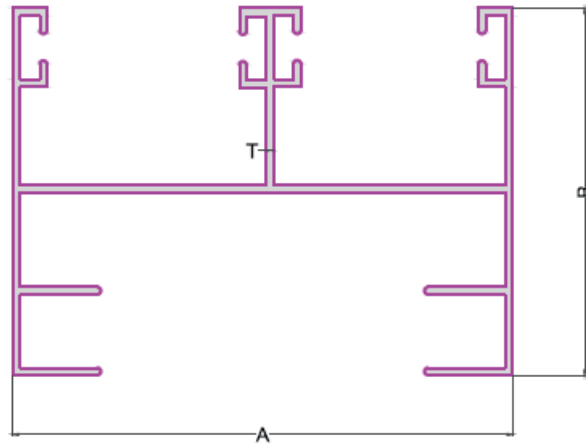

SL NO.	SECTION NO	A	B	T	WEIGHT RANGE KG/12'
1	1551	62.00	45.50	0.95	2.200-2.500

HOLLOW-2 TRACK BOTTOM

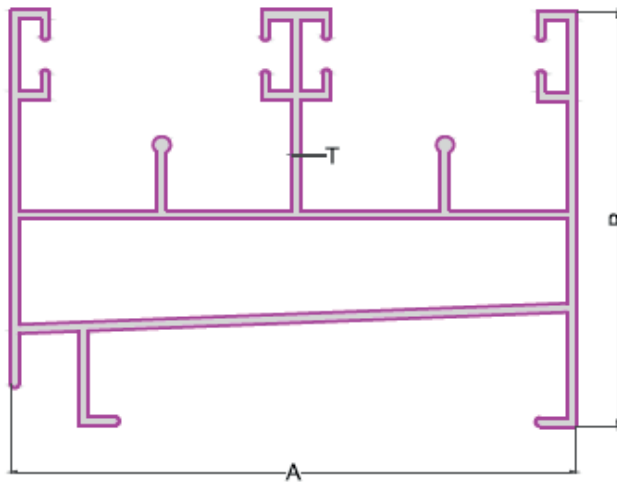

SL NO.	SECTION NO	A	B	T	WEIGHT RANGE KG/12'
1	1552	61.90	45.00	0.95	3.000-3.300

HOLLOW-3 TRACK TOP

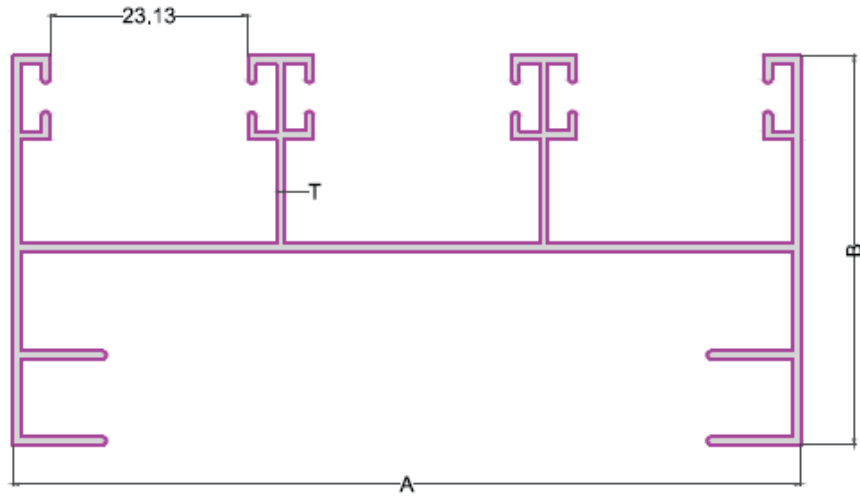

SL NO.	SECTION NO	A	B	T	WEIGHT RANGE KG/12'
1	1553	92.00	45.50	0.95	3.000-3.300

HOLLOW-3 TRACK BOTTOM

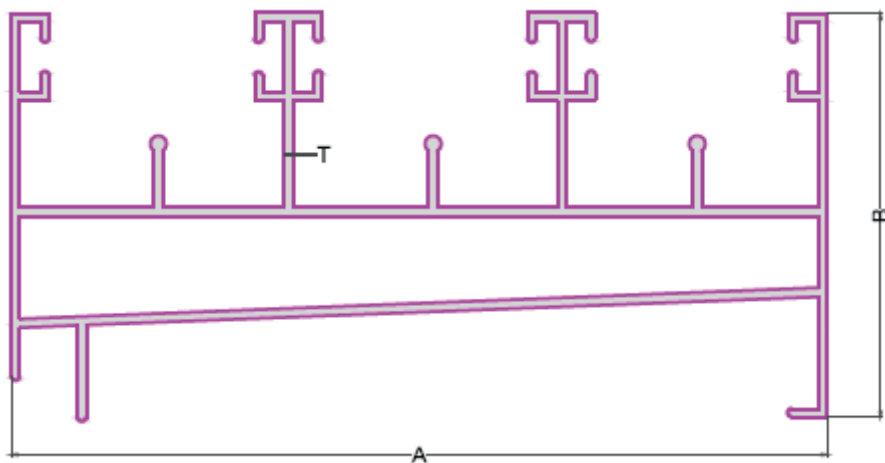

SL NO.	SECTION NO	A	B	T	WEIGHT RANGE KG/12'
1	1554	91.90	45.00	1.00	4.000-4.300
2	1555	91.90	45.00	2.50	6.900-7.200

DIE NO 201213

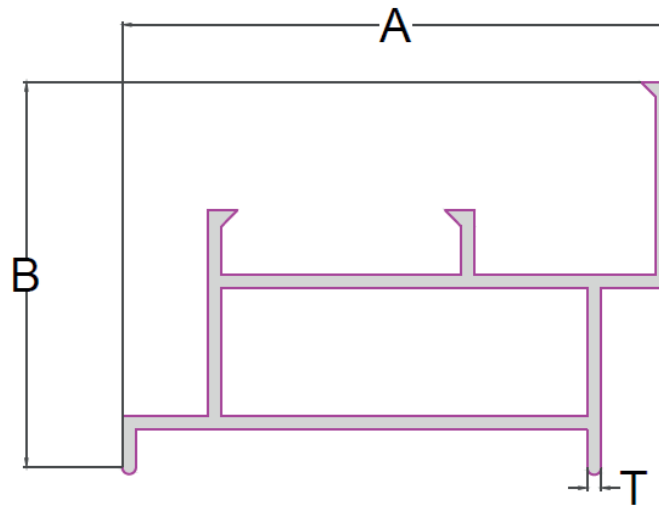

SL NO.	SECTION NO	A	B	T	WEIGHT RANGE KG/12'
1	1556	44.00	30.2	1.06	1.400-1.600
2	1557	44.00	30.2	1.21	1.600-1.800

DIE NO 201214

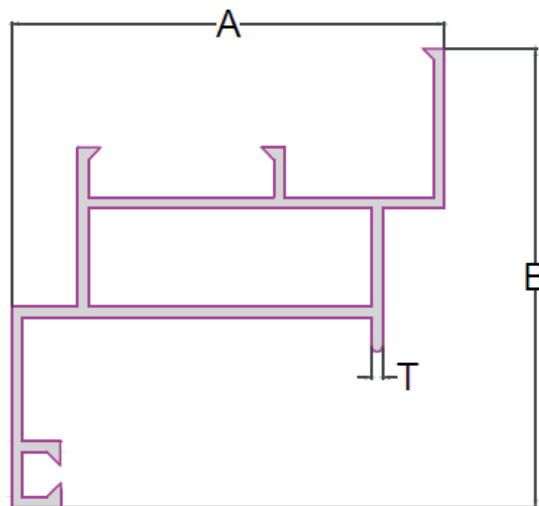

SL NO.	SECTION NO	A	B	T	WEIGHT RANGE KG/12'
1	1558	43.9	46.6	1.03	1.600-1.800
2	1559	43.9	46.6	1.15	1.800-2.000

MULLION SERIES

MULLION

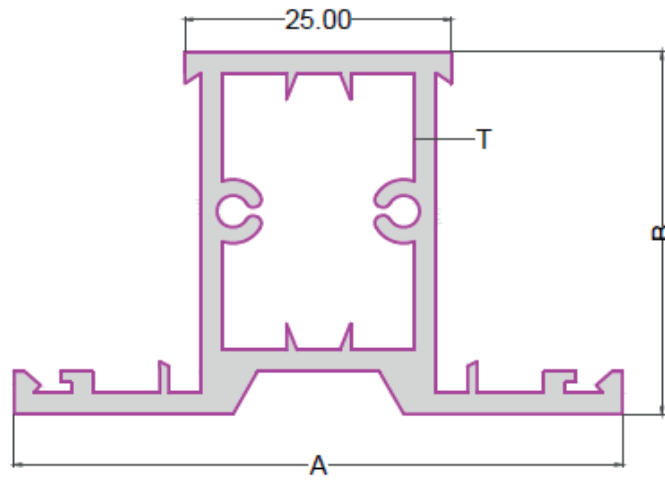

SL NO.	SECTION NO	A	B	T	WEIGHT RANGE KG/12'
1	1560	57.00	34.00	2.00	2.000-2.200
2	1561	57.00	34.00	2.10	2.200-2.400

MULLION CHAIR

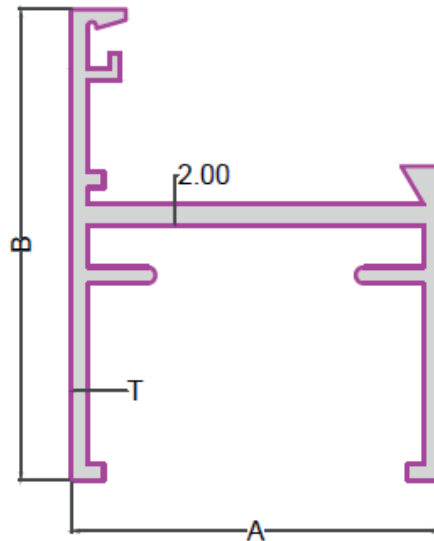

SL NO.	SECTION NO	A	B	T	WEIGHT RANGE KG/12'
1	1562	34.00	43.50	1.50	1.700-1.800
2	1563	34.00	43.50	1.65	1.900-2.000

MULLION Z

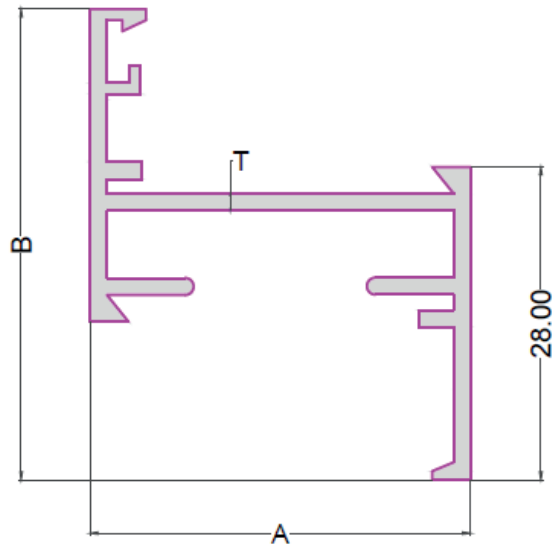

SL NO.	SECTION NO	A	B	T	WEIGHT RANGE KG/12'
1	1564	34.00	43.50	1.50	1.400-1.600
2	1565	34.00	43.50	1.75	1.800-2.000

MULLION CLIP

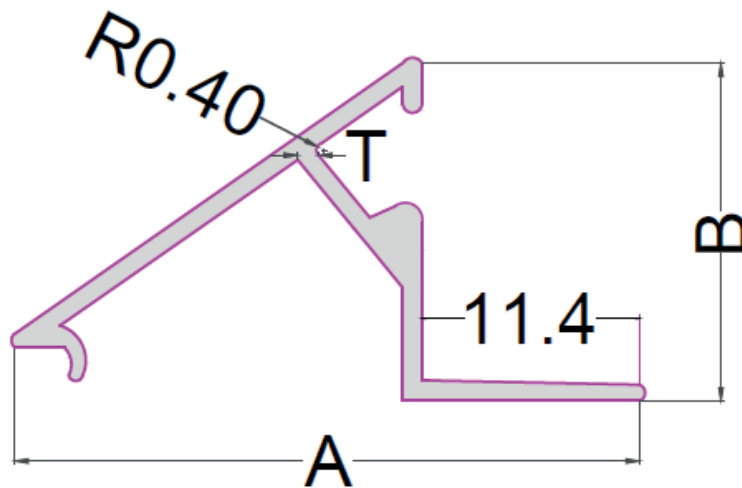

SL NO.	SECTION NO	A	B	T	WEIGHT RANGE KG/12'
1	1566	32.75	17.7	1.00	0.500-0.700

LOUVER SERIES

3" 2 LOUVER [1305]

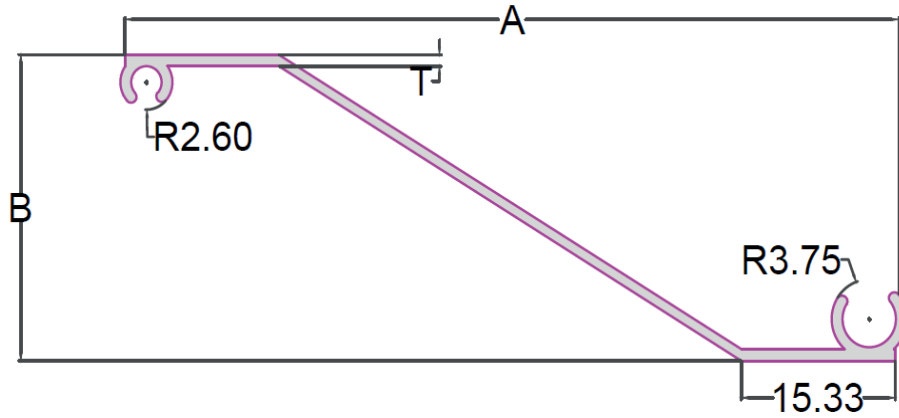

SL NO.	SECTION NO	A	B	T	WEIGHT RANGE KG/12'
1	1567	77.17	29.04	1.10	1.000-1.100
2	1568	77.17	29.04	1.20	1.200-1.300

DIE NO 1333

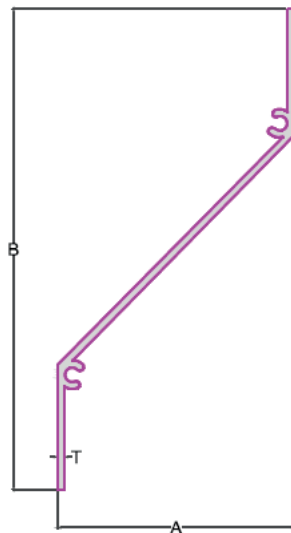

SL NO.	SECTION NO	A	B	T	WEIGHT RANGE KG/12'
1	1569	50.80	103.20	1.50	1.800-2.000

OVEL SERIES

OVEL SECTION

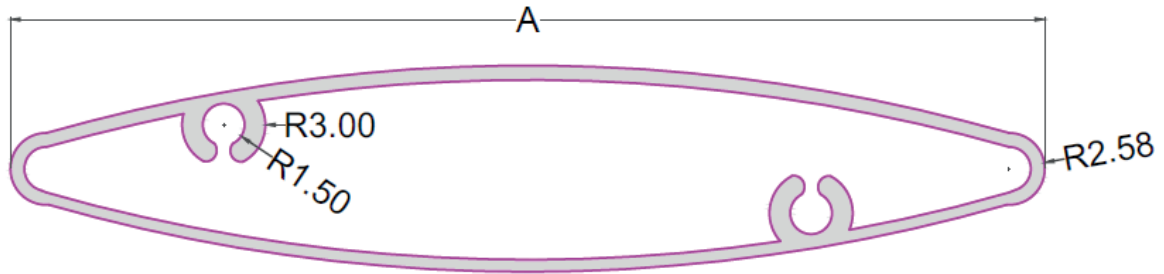

SL NO.	SECTION NO	A	WEIGHT RANGE KG/12'
1	1570	50.8	1.300-1.600
2	1571	74.50	2.000-2.200
3	1572	100.00	3.800-4.000

'L' PIPE SERIES

2 X 1 L PIPE

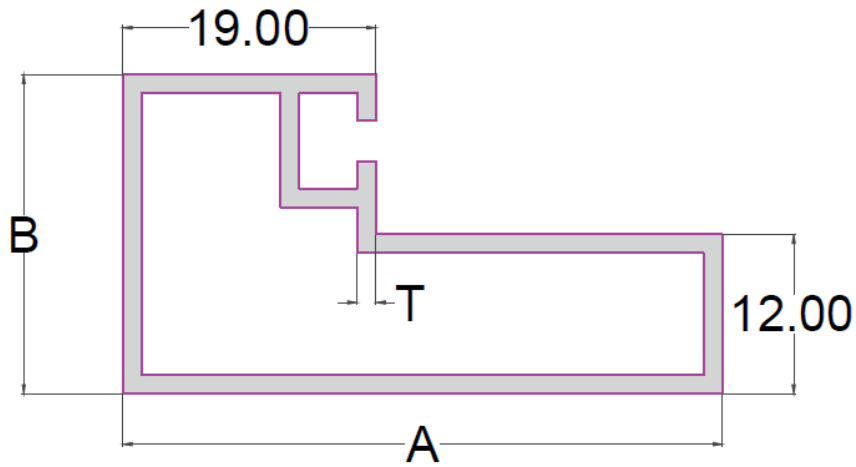

SL NO.	SECTION NO	A	B	T	WEIGHT RANGE KG/12'
1	1573	50.00	25.00	1.40	1.500-1.700

1.5 X 1 L PIPE

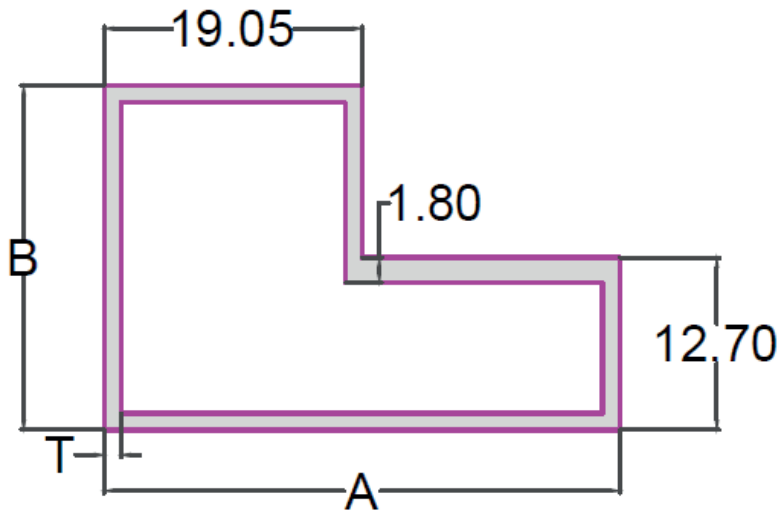

SL NO.	SECTION NO	A	B	T	WEIGHT RANGE KG/12'
1	1574	38.00	25.00	1.20	1.400-1.600

2.5 X 1.5 L PIPE

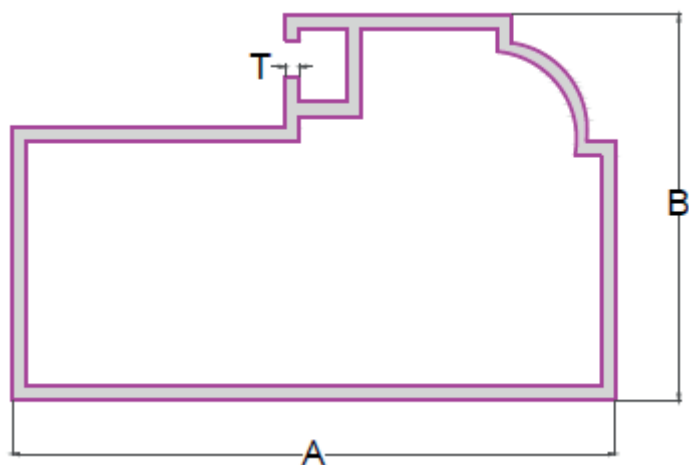

SL NO.	SECTION NO	A	B	T	WEIGHT RANGE KG/12'
1	1575	64.00	41.00	1.50	2.400-2.600

OTHER

BULB T

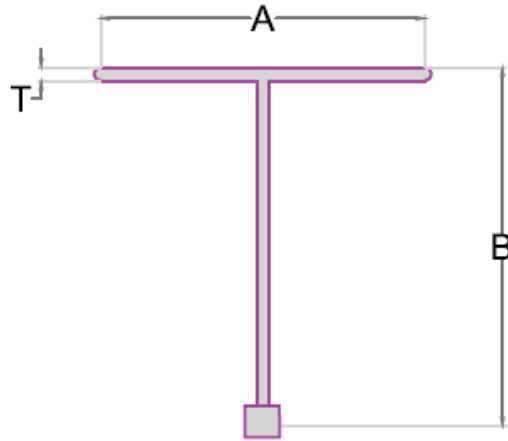

SL NO.	SECTION NO	A	B	T	WEIGHT RANGE KG/12'
1	1576	25.00	25.00	0.60	0.300-0.400
2	1577	25.00	25.00	1.30	0.700-0.800
3	1578	38.00	38.00	1.30	1.000-1.200
4	1579	38.00	38.00	1.70	1.300-1.400

DGC

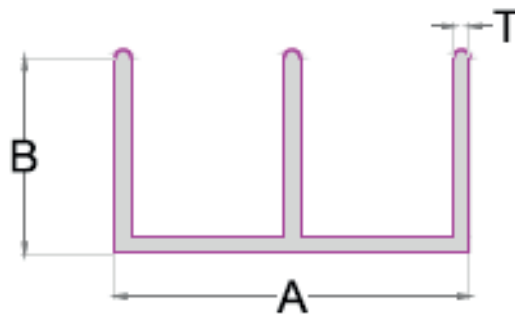

SL NO.	SECTION NO	A	B	T	WEIGHT RANGE KG/12'
1	1580	22.00	12.00	0.94	0.400-0.500
2	1581	22.00	12.00	1.03	0.500-0.700
3	1582	30.00	12.00	0.80	0.500-0.700

GLAZING CLIP

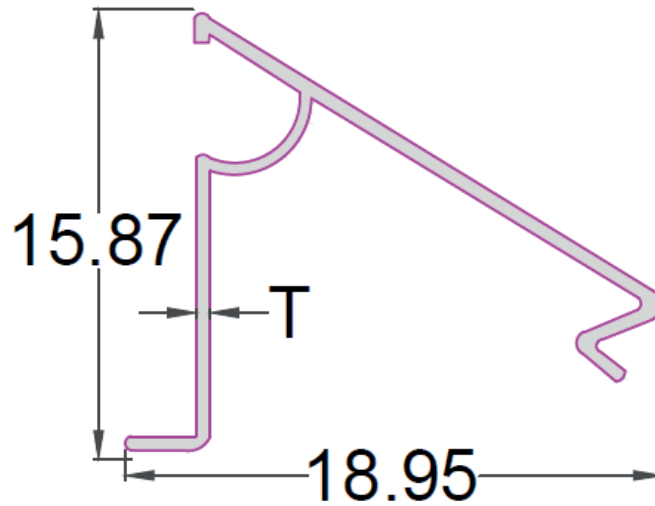

SL NO.	SECTION NO	T	WEIGHT RANGE KG/12'
1	1583	0.50	0.250-0.300
2	1584	0.71	0.300-0.350
3	1585	0.76	0.400-0.450

1" HALF ROUND

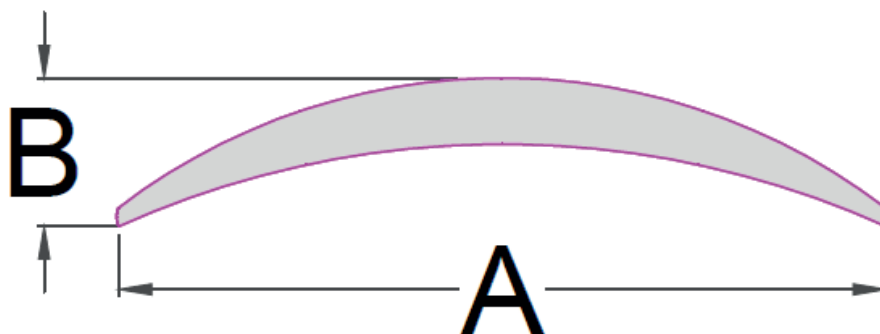

SL NO.	SECTION NO	A	B	WEIGHT RANGE KG/12'
1	1586	23.5	4.5	0.400-0.500
2	1587	23.5	4.5	0.600-0.700

50MM HANDLE WITH BULB

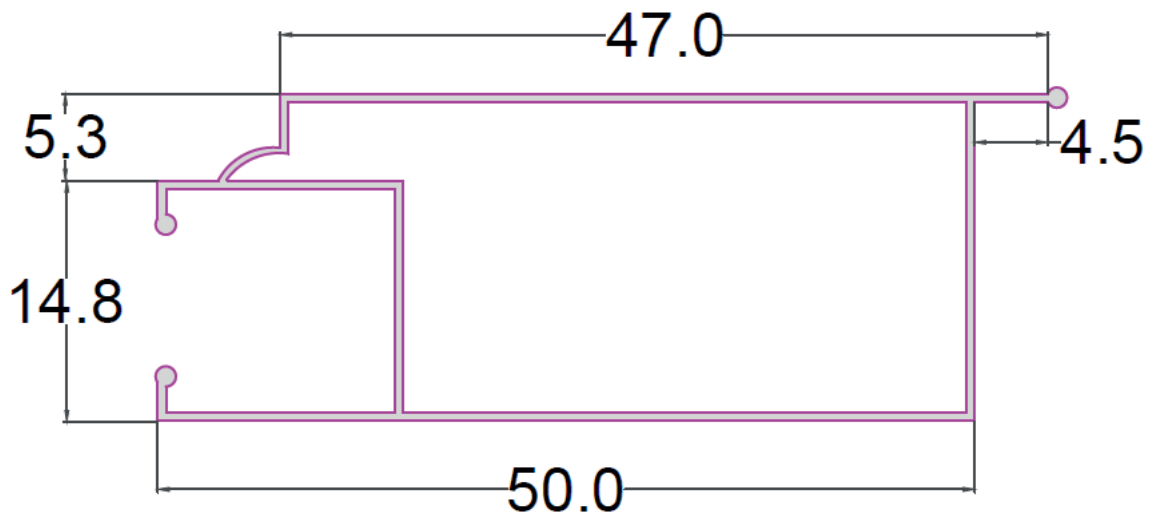

BIG MESH NET

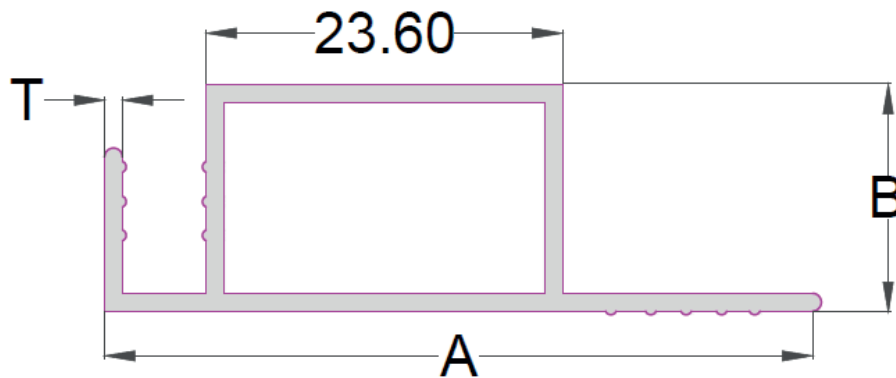

SL NO.	SECTION NO	A	B	T	WEIGHT RANGE KG/12'
1	1588	46.90	15.06	1.19	1.300-1.400

D.C.M

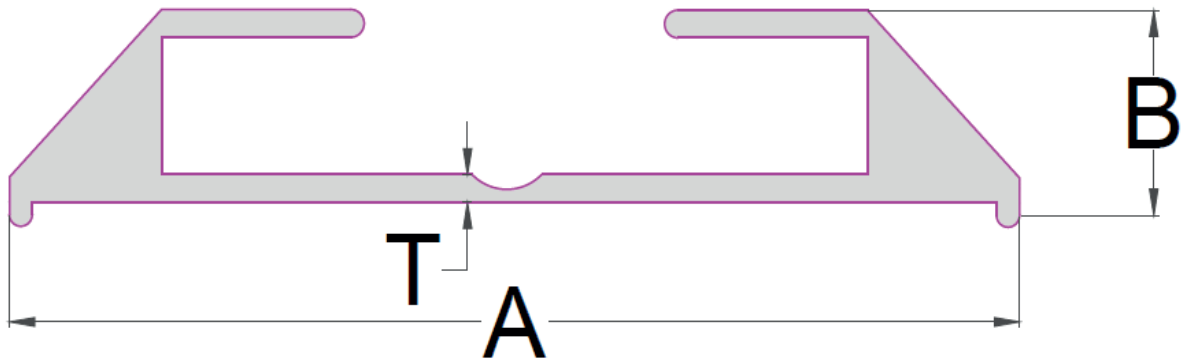

SL NO.	SECTION NO	A	B	T	WEIGHT RANGE KG/12'
1	1589	39.9	7.9	1.10	0.950-1.100

DOOR C GEAR

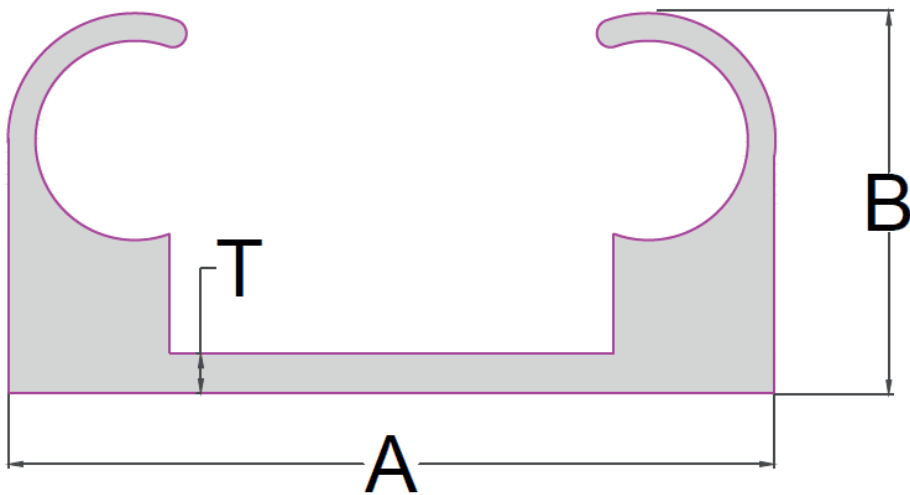

SL NO.	SECTION NO	A	B	T	WEIGHT RANGE KG/12'
1	1590	36.6	18.3	1.90	1.650-1.750

DOOR G GEAR

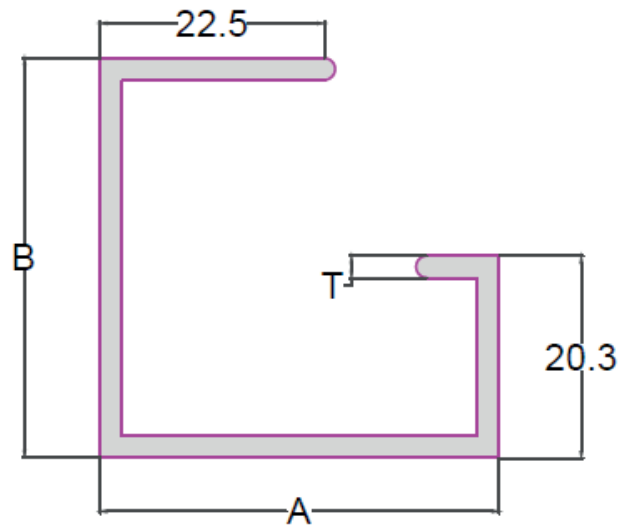

SL NO.	SECTION NO	A	B	T	WEIGHT RANGE KG/12'
1	1591	40.00	40.00	2.20	1.700-1.800

DRAWER SECTION

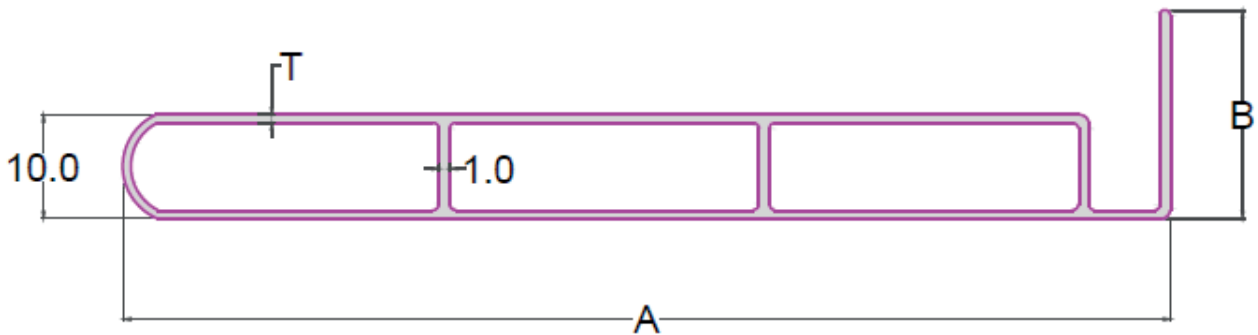

SL NO.	SECTION NO	A	B	T	WEIGHT RANGE KG/12'
1	1592	100.5	19.5	1.00	2.000-2.300

FLOWER BRACKET

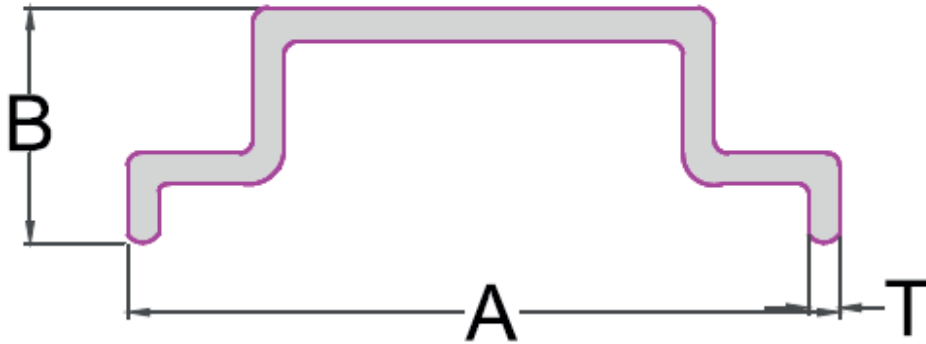

SL NO.	SECTION NO	A	B	T	WEIGHT RANGE KG/12'
1	1593	23.00	7.34	1.00	0.300-0.350

GLAZING PATTA

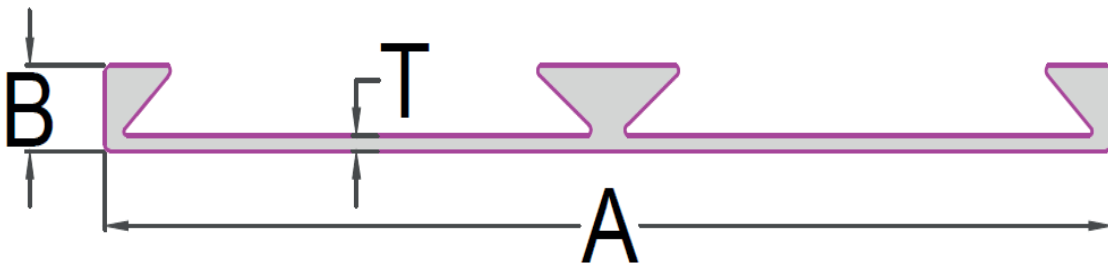

SL NO.	SECTION NO	A	B	T	WEIGHT RANGE KG/12'
1	1594	44.45	3.11	0.57	0.500-0.600

H SECTION

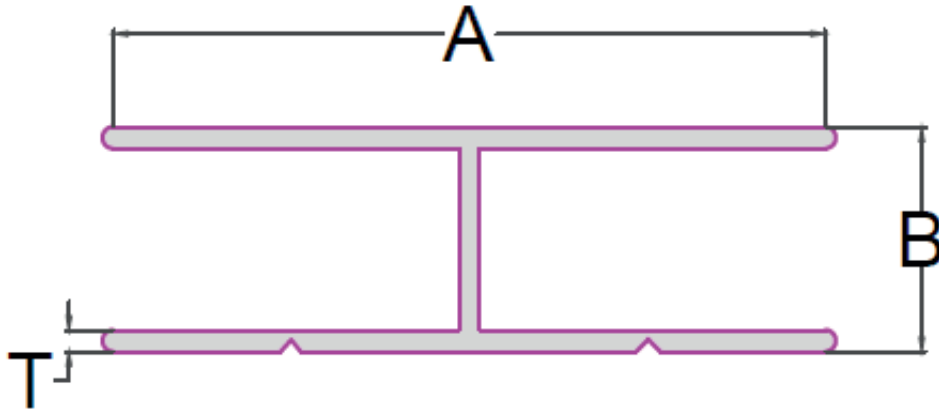

SL NO.	SECTION NO	A	B	T	WEIGHT RANGE KG/12'
1	1595	35.00	11.00	0.49	0.350-0.500
2	1596	35.00	11.00	0.92	0.700-0.800
3	1597	35.00	11.00	1.97	1.550-1.650

J WATER CHANNEL

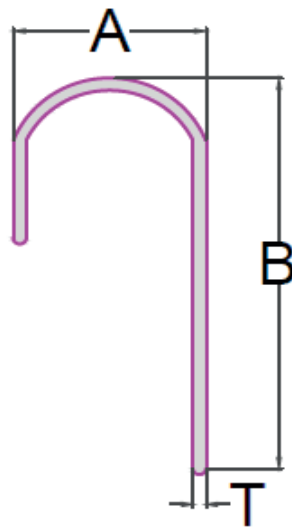

SL NO.	SECTION NO	A	B	T	WEIGHT RANGE KG/12'
1	1598	11.8	25.00	0.62	0.300-0.400
2	1599	11.8	25.00	0.98	0.500-0.600
3	1600	11.8	30.00	1.77	0.850-0.950

KEY GOLA

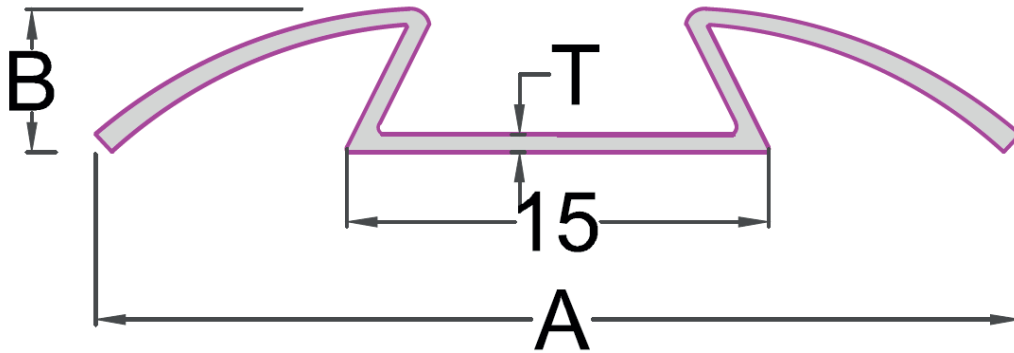

SL NO.	SECTION NO	A	B	T	WEIGHT RANGE KG/12'
1	1601	31.09	4.80	0.60	0.300-0.450
2	1602	31.09	4.80	0.80	0.700-0.800

MESH NET

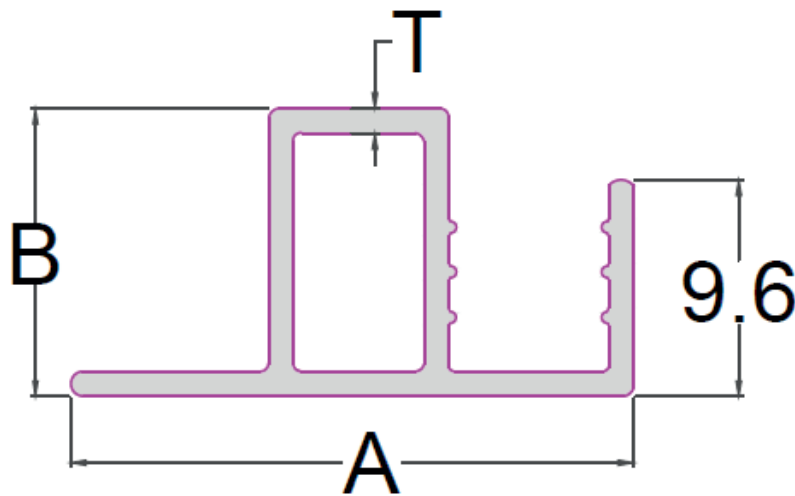

SL NO.	SECTION NO	A	B	T	WEIGHT RANGE KG/12'
1	1603	24.4	12.8	1.10	0.600-0.700
2	1604	24.4	12.8	1.20	0.850-0.950

SHOWCASE

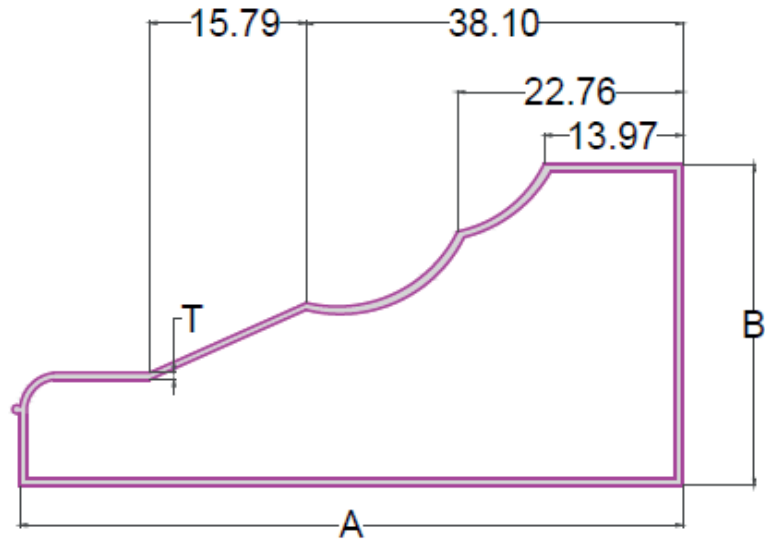

SL NO.	SECTION NO	A	B	T	WEIGHT RANGE KG/12'
1	1605	67.00	32.50	0.70	1.300-1.450

SHOWCASE WITH LEG

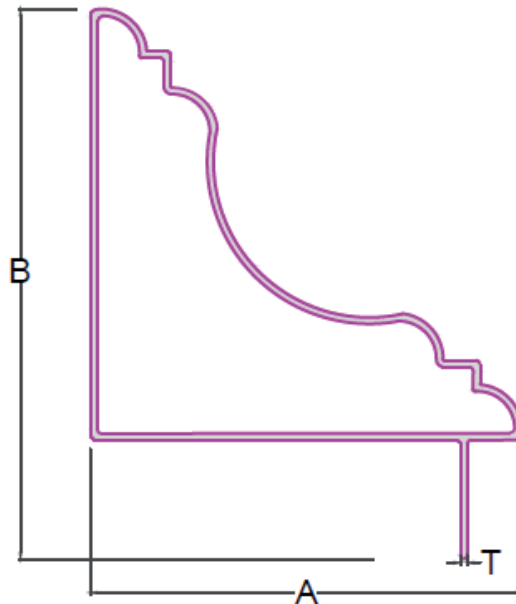

SL NO.	SECTION NO	A	B	T	WEIGHT RANGE KG/12'
1	1606	47.05	47.20	0.75	1.450-1.600

STEP EDGE

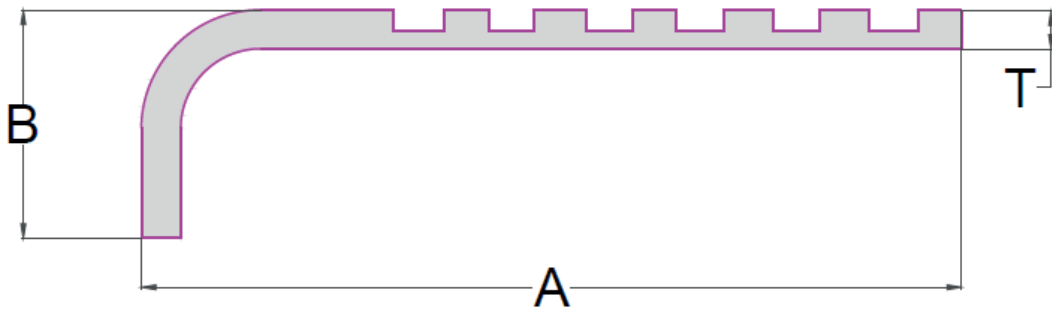

SL NO.	SECTION NO	A	B	T	WEIGHT RANGE KG/12'
1	1607	38.00	13.00	0.95	0.700-0.900
2	1608	38.00	13.00	1.50	1.500-1.700
3	1609	57.15	15.88	1.50	1.300-1.500

T WITHOUT BULB

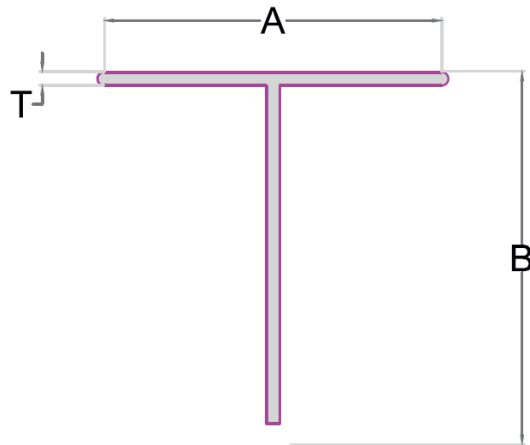

SL NO.	SECTION NO	A	B	T	WEIGHT RANGE KG/12'
1	1610	18.00	18.00	0.72	0.200-0.350
2	1611	25.00	25.00	0.70	0.300-0.400
3	1612	25.00	25.00	1.46	0.700-0.800
4	1613	50.00	25.00	1.81	1.300-1.400
5	1614	50.00	25.00	2.72	2.000-2.100

TRANSPORT F

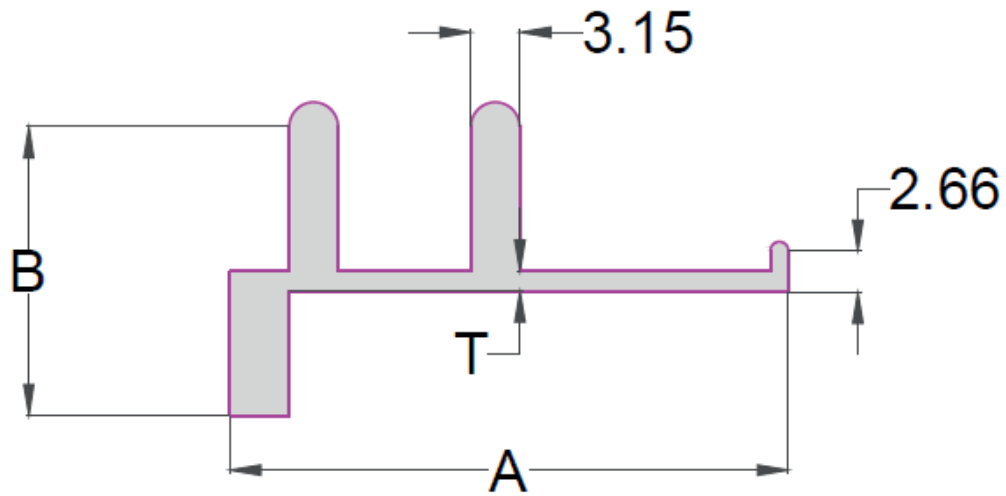

SL NO.	SECTION NO	A	B	T	WEIGHT RANGE KG/12'
1	1615	36.00	18.60	1.43	1.400-1.600

TRANSPORT H

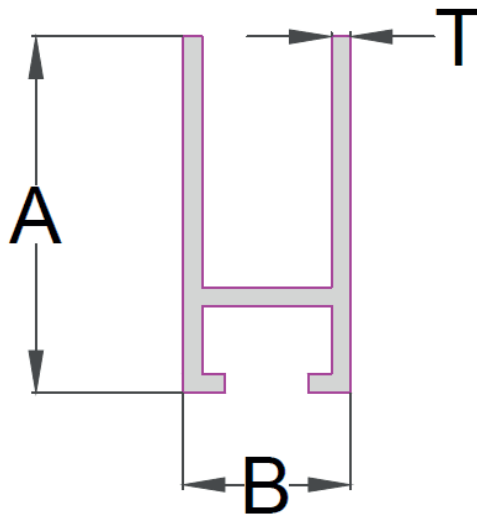

SL NO.	SECTION NO	A	B	T	WEIGHT RANGE KG/12'
1	1616	17.00	8.00	0.91	0.400-0.600
2	1617	17.00	8.00	1.37	0.600-0.800
3	1618	17.00	8.00	3.66	1.600-1.800

TVS WATER CHANNEL

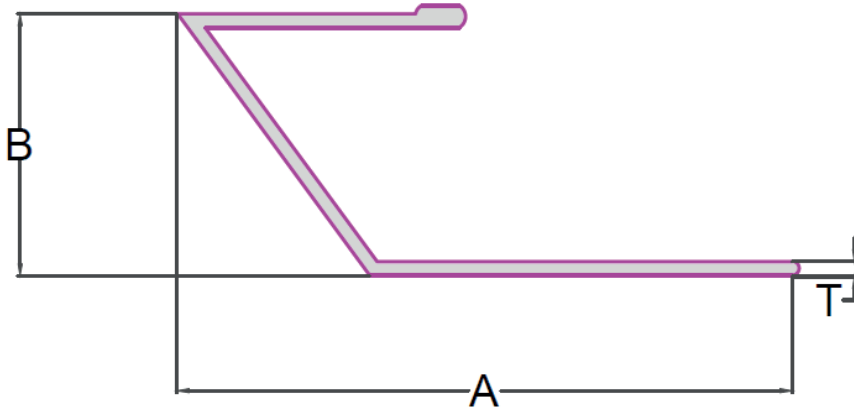

SL NO.	SECTION NO	A	B	T	WEIGHT RANGE KG/12'
1	1619	50.5	22.6	1.17	1.000-1.200

V CLIP

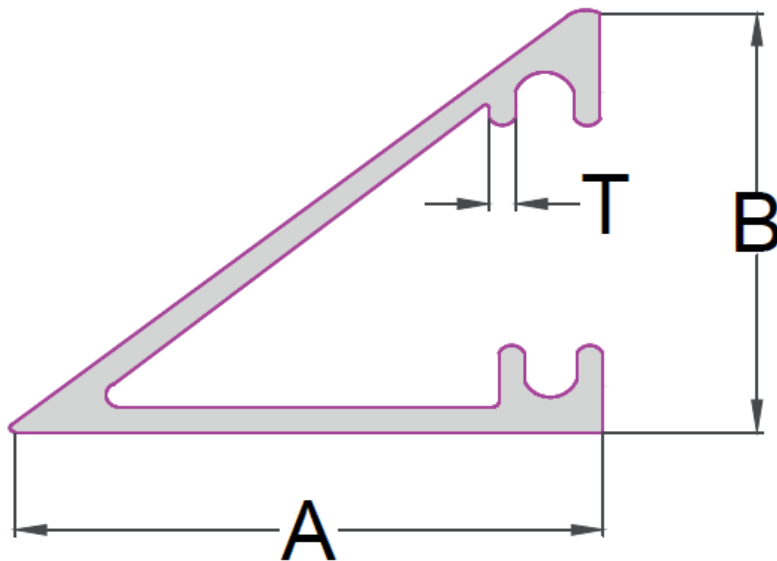

SL NO.	SECTION NO	A	B	T	WEIGHT RANGE KG/12'
1	1620	18.00	13.00	0.80	0.300-0.500

VOLVO HALF ROUND

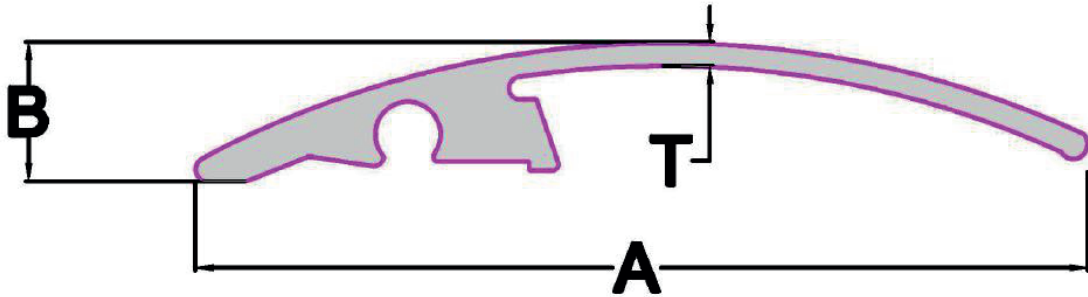

SL NO.	SECTION NO	A	B	T	WEIGHT RANGE KG/12'
1	1621	50.00	7.59	1.47	1.000-1.200
2	1622	50.00	7.59	1.77	1.200-1.400

DIE NO A-0914

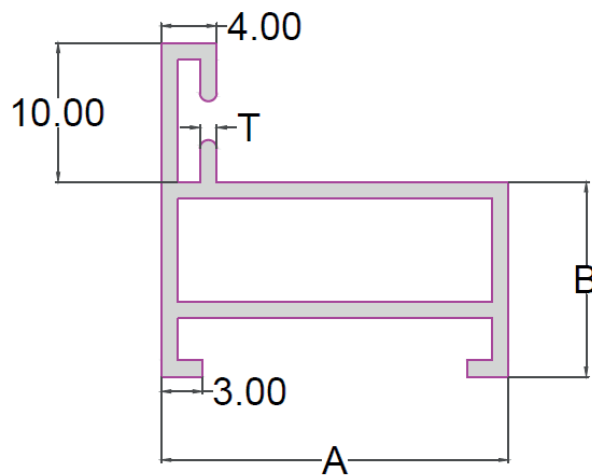

SL NO.	SECTION NO	A	B	T	WEIGHT RANGE KG/12'
1	1623	25.00	24.00	1.20	1.000-1.200

DIE NO A-0915

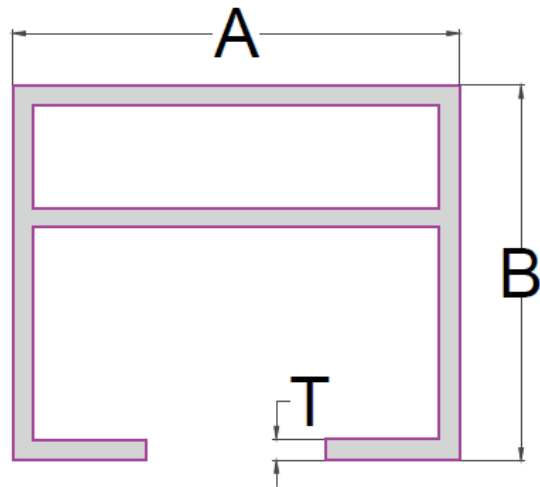

SL NO.	SECTION NO	A	B	T	WEIGHT RANGE KG/12'
1	1624	25.00	21.00	1.20	1.300-1.500

DIE NO A-0916

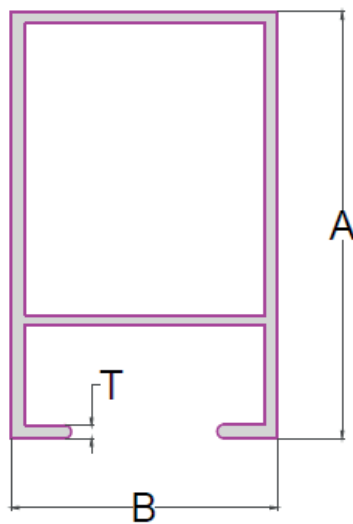

SL NO.	SECTION NO	A	B	T	WEIGHT RANGE KG/12'
1	1625	40.00	25.00	1.20	1.100-1.300

DIE NO A-0922

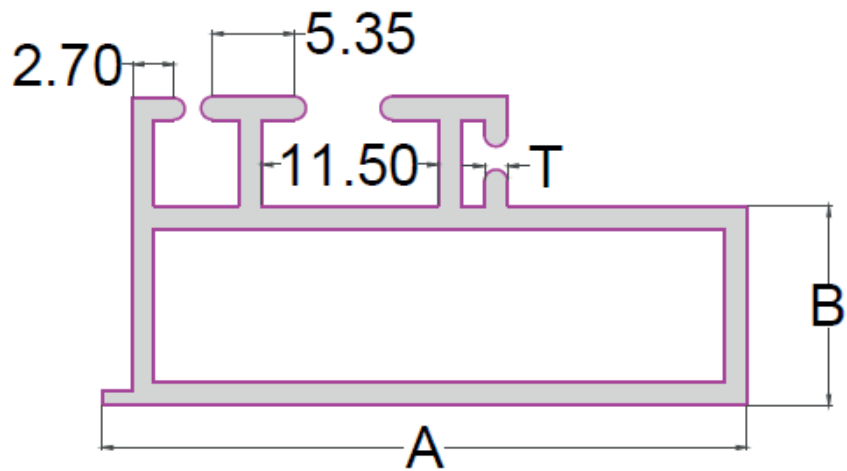

SL NO.	SECTION NO	A	B	T	WEIGHT RANGE KG/12'
1	1626	42.00	20.00	1.50	2.200-2.400

DIE NO A-0923

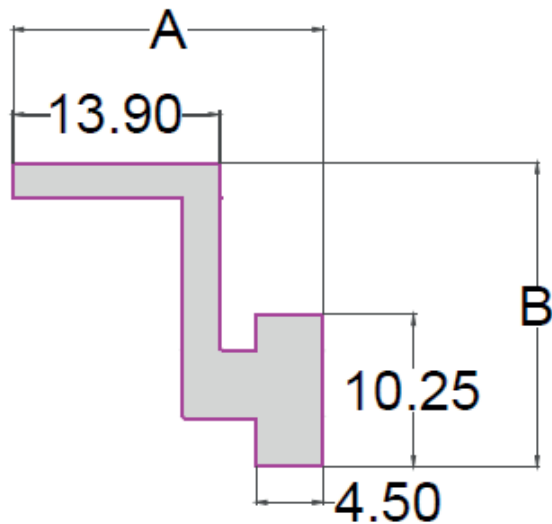

SL NO.	SECTION NO	A	B	WEIGHT RANGE KG/12'
1	1627	20.90	20.50	1.200-1.300

DIE NO 0922

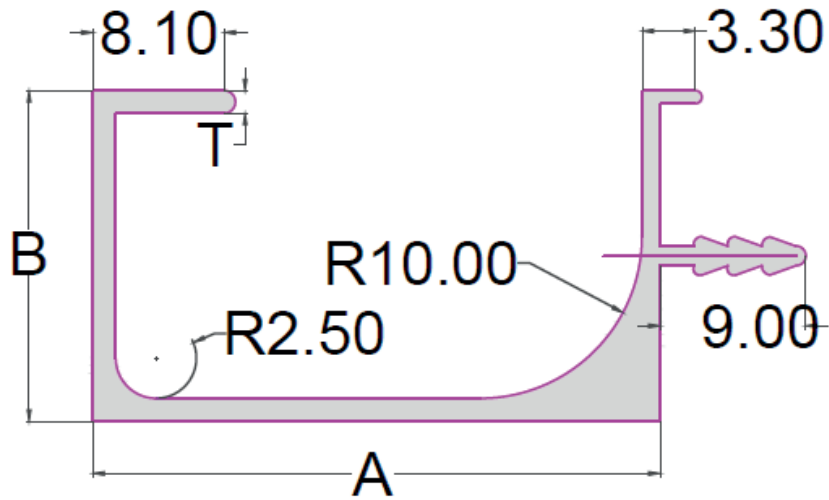

SL NO.	SECTION NO	A	B	T	WEIGHT RANGE KG/12'
1	1627	44.00	20.40	1.40	1.400-1.600

DIE NO A-0921

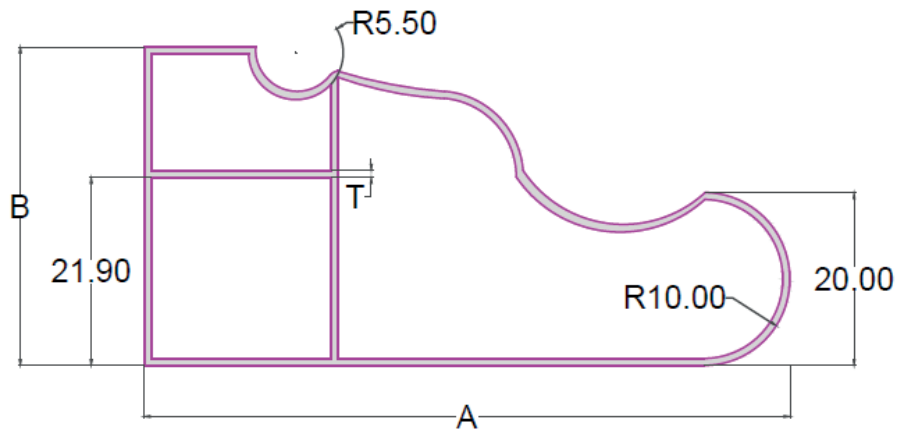

SL NO.	SECTION NO	A	B	T	WEIGHT RANGE KG/12'
1	1628	75.30	37.10	0.80	1.800-1.900

DIE NO 20121

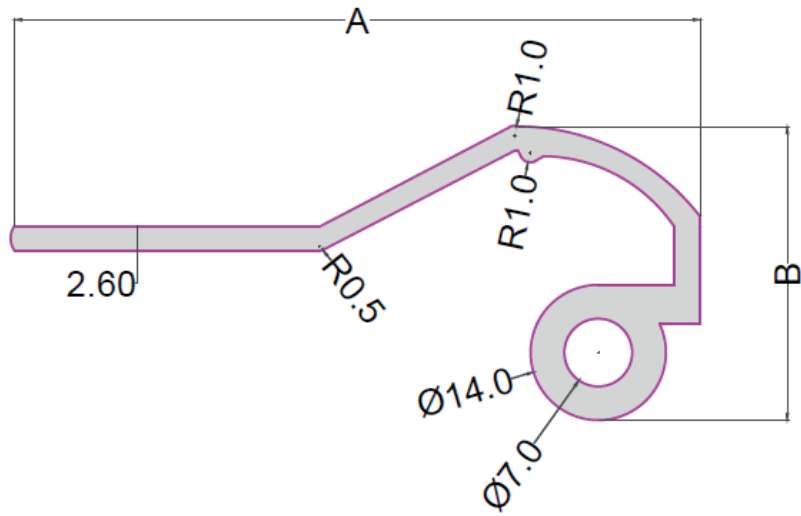

SL NO.	SECTION NO	A	B	WEIGHT RANGE KG/12'
1	1629	71.00	30.7	3.600-3.800

DIE NO 201212

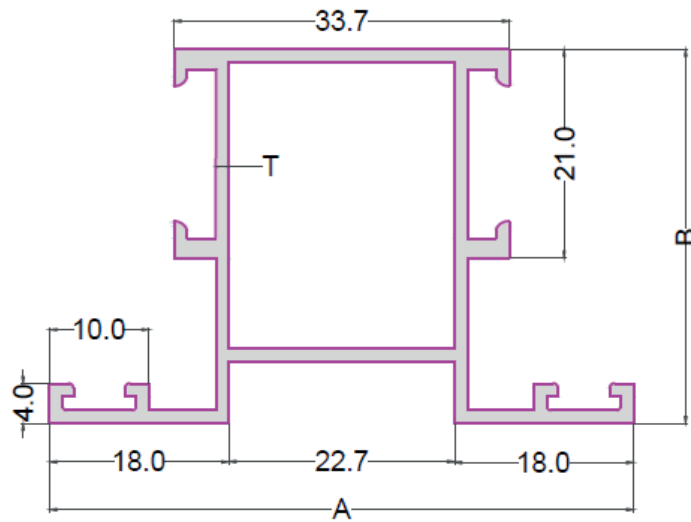

SL NO.	SECTION NO	A	B	T	WEIGHT RANGE KG/12'
1	1630	58.7	37.6	1.30	2.300-2.500

DIE NO 201215

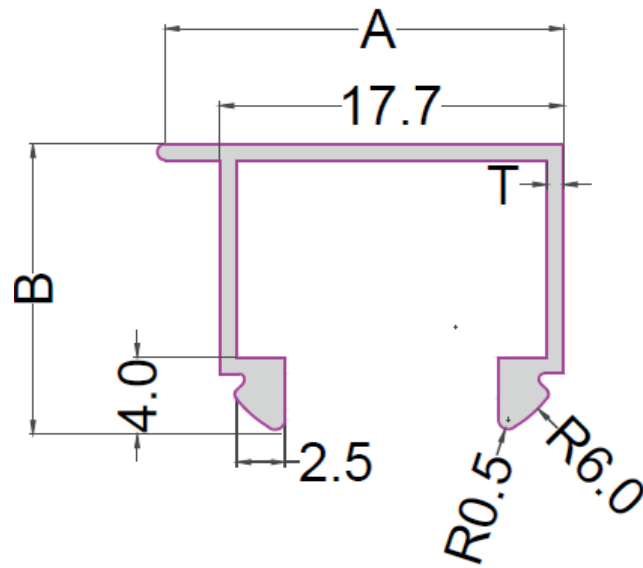

SL NO.	SECTION NO	A	B	T	WEIGHT RANGE KG/12'
1	1631	20.5	15.0	0.80	0.400-0.600

DIE NO 201216

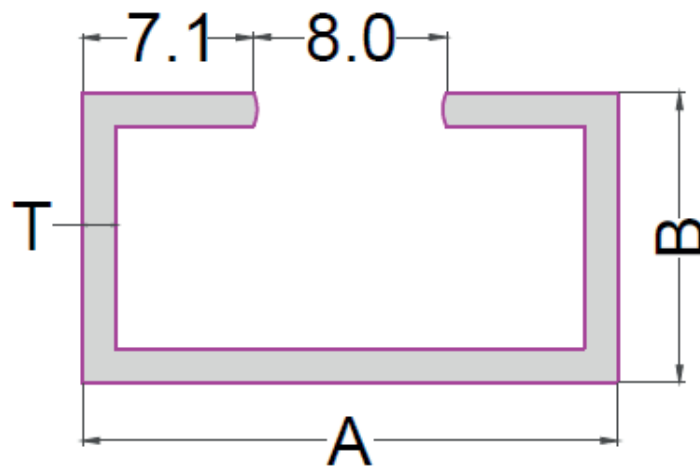

SL NO.	SECTION NO	A	B	T	WEIGHT RANGE KG/12'
1	1632	22.2	12.0	1.4	0.600-0.800

DIE NO 201217

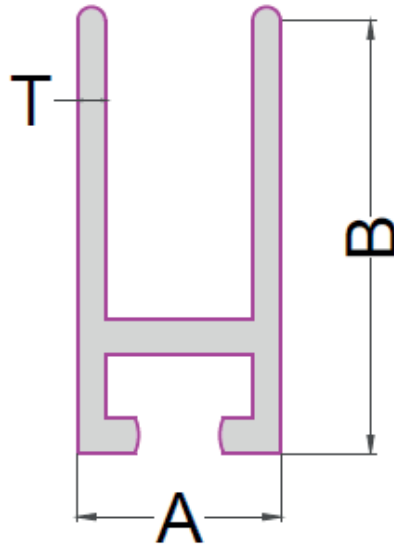

SL NO.	SECTION NO	A	B	T	WEIGHT RANGE KG/12'
1	1633	8.00	17.00	1.40	0.400-0.600

DIE NO 201218

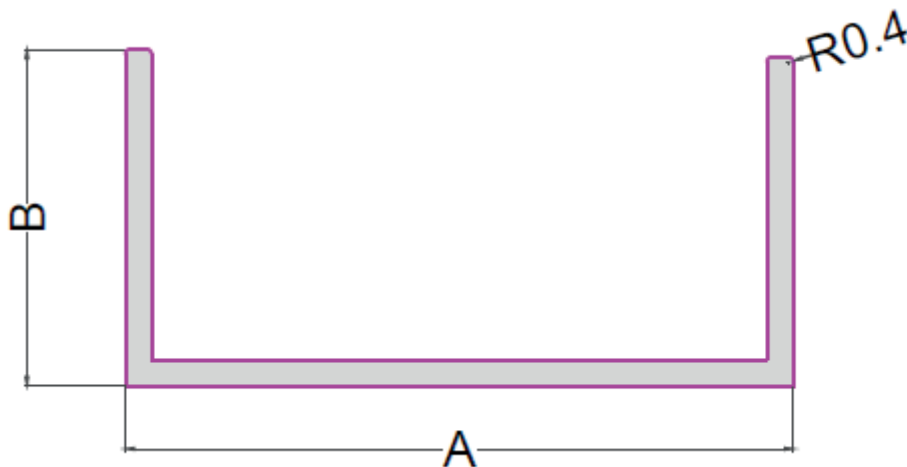

SL NO.	SECTION NO	A	B	T	WEIGHT RANGE KG/12'
1	1634	50.9	25.6	2.00	1.800-2.000

DIE NO 0924

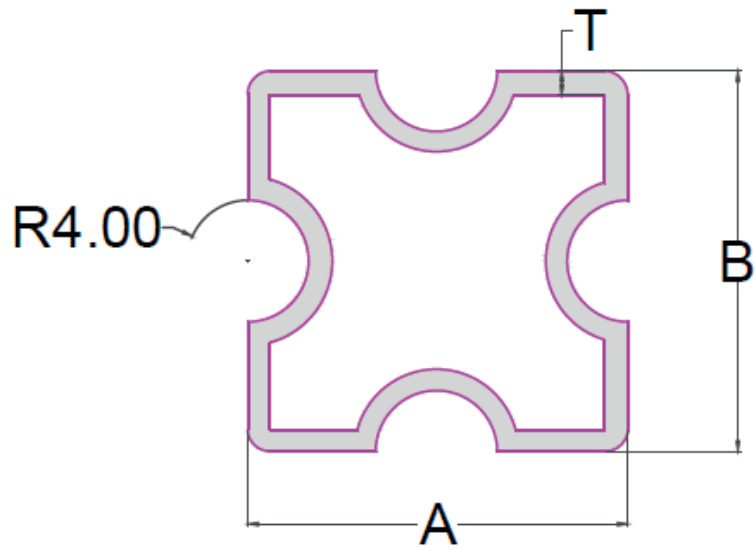

SL NO.	SECTION NO	A	B	T	WEIGHT RANGE KG/12'
1	1635	25.00	25.00	1.60	1.600-1.800

DIE NO 0900

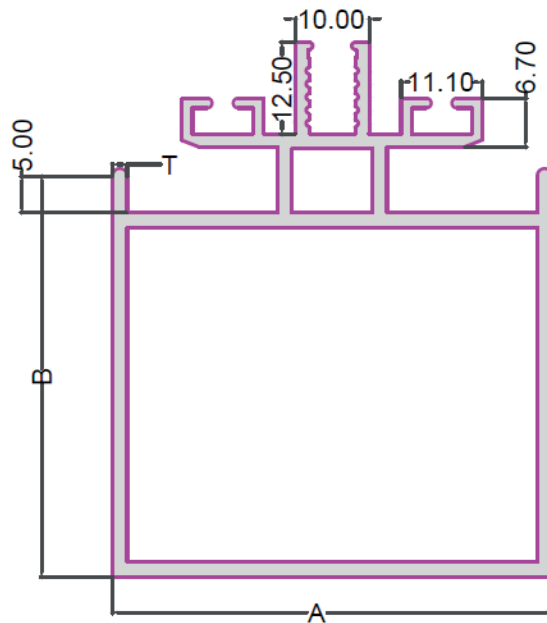

SL NO.	SECTION NO	A	B	T	WEIGHT RANGE KG/12'
1	1636	60.00	75.00	2.00	6.700-6.900

DIE NO 6920 [DGU]

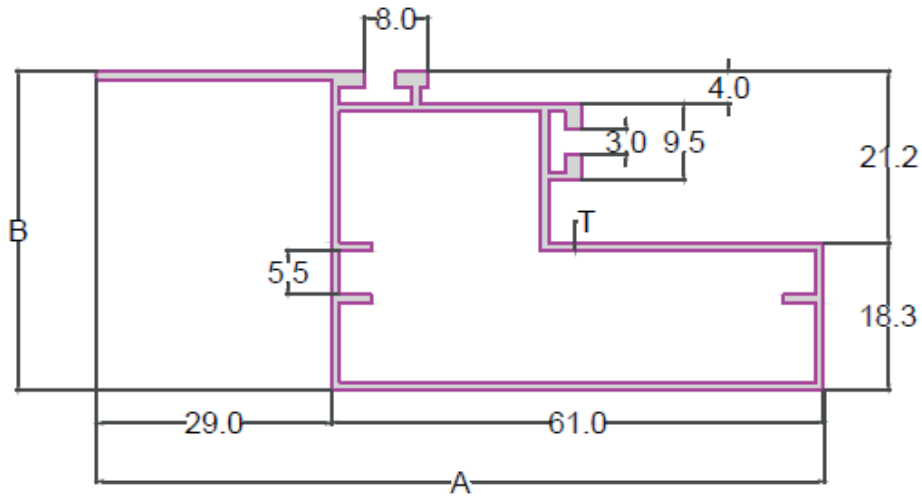

SL NO.	SECTION NO	A	B	T	WEIGHT RANGE KG/12'
1	1637	90.00	39.50	1.00	2.800-3.100

DIE NO 6921 [SGU]

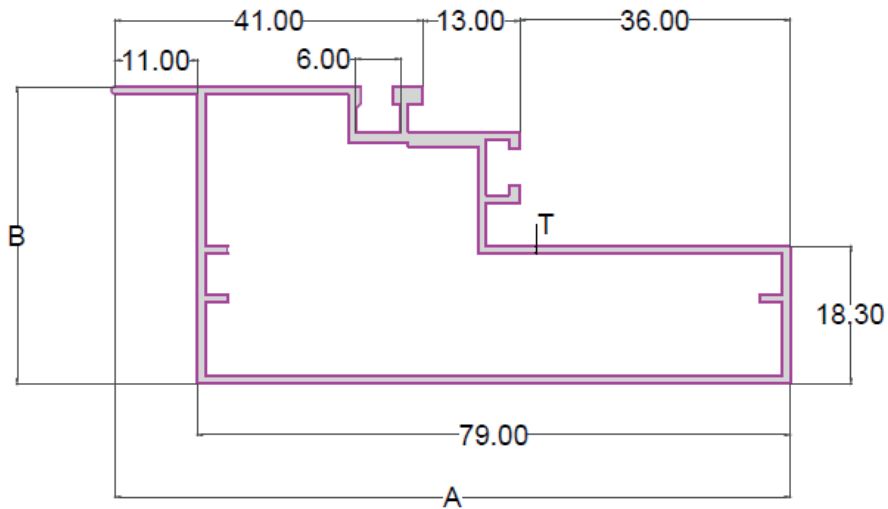

SL NO.	SECTION NO	A	B	T	WEIGHT RANGE KG/12'
1	1638	90.00	39.50	1.10	3.000-3.200
2	1639	90.00	39.50	1.45	3.800-4.000

FOOTPRINT

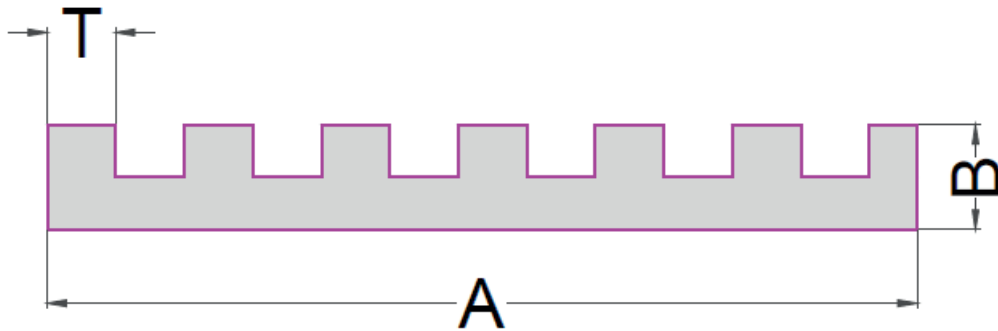

SL NO.	SECTION NO	A	B	T	WEIGHT RANGE KG/12'
1	1640	32.00	3.40	3.00	0.700-0.900

TRPT MAZDA BEEDING

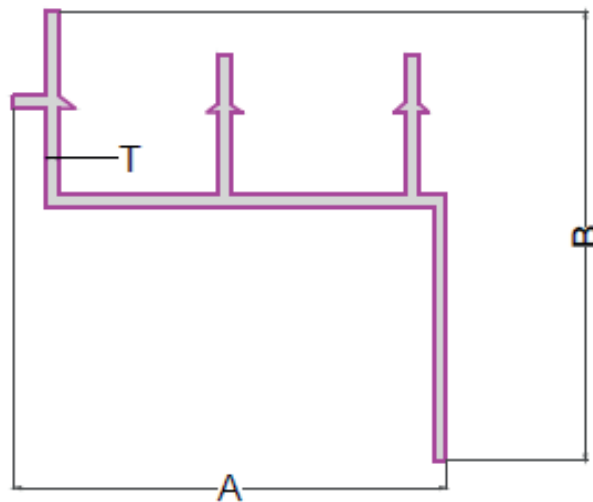

SL NO.	SECTION NO	A	B	T	WEIGHT RANGE KG/12'
1	1641	43.30	45.00	2.30	2.700-2.900

DIE NO 0909

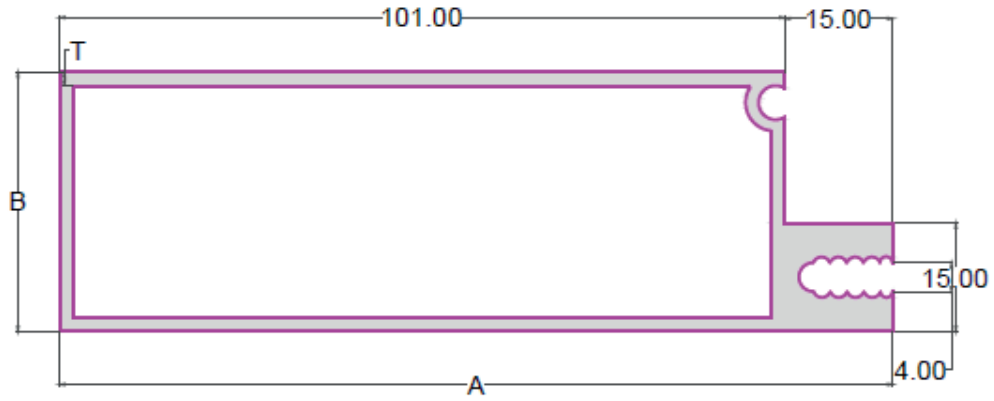

SL NO.	SECTION NO	A	B	T	WEIGHT RANGE KG/12'
1	1642	101.00	36.00	1.50	6.600-6.800

S1

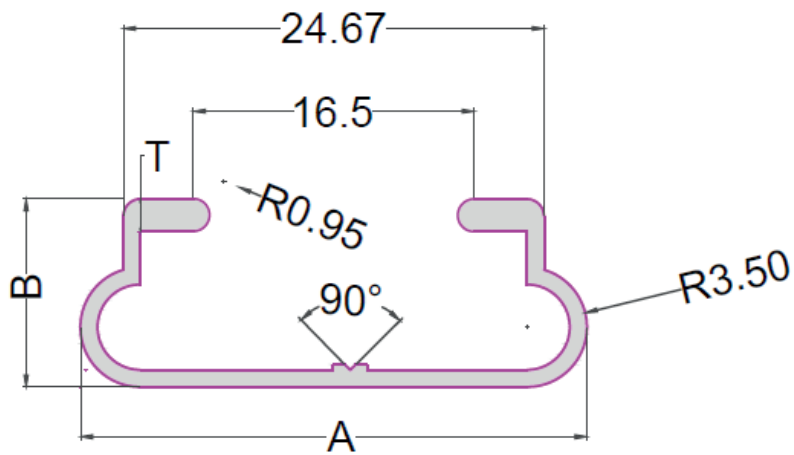

SL NO.	SECTION NO	A	B	T	WEIGHT RANGE KG/12'
1	1643	29.7	11.00	1.00	0.500-0.700

S2

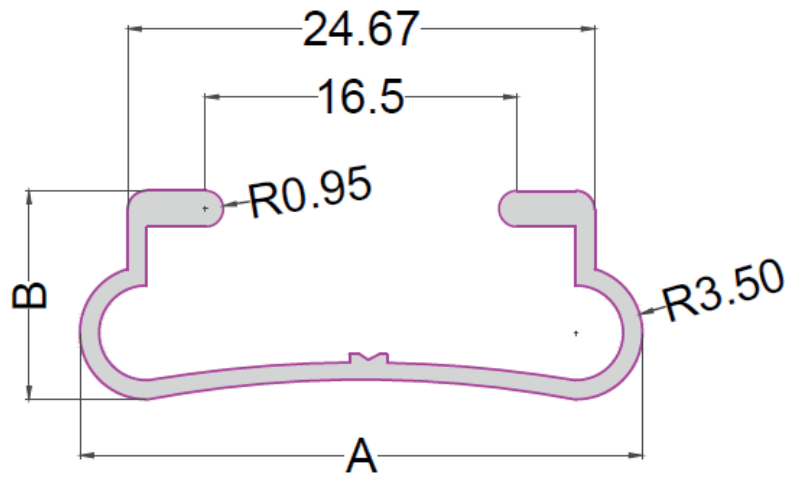

SL NO.	SECTION NO	A	B	T	WEIGHT RANGE KG/12'
1	1644	29.7	11.00	0.90	0.600-0.800

M2

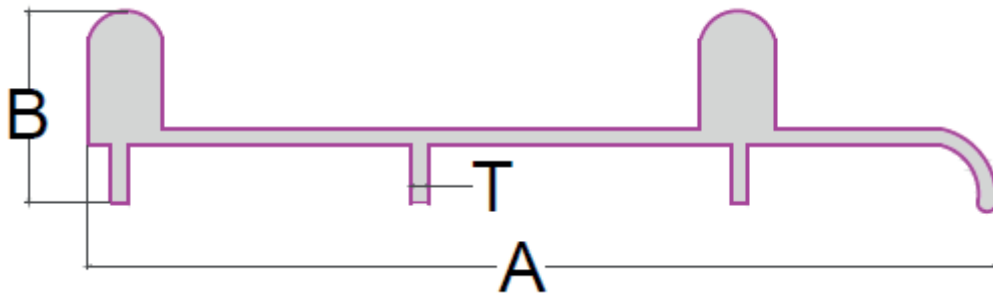

SL NO.	SECTION NO	A	B	T	WEIGHT RANGE KG/12'
1	1645	49.00	10.30	1.00	1.200-1.300

GRILL-F

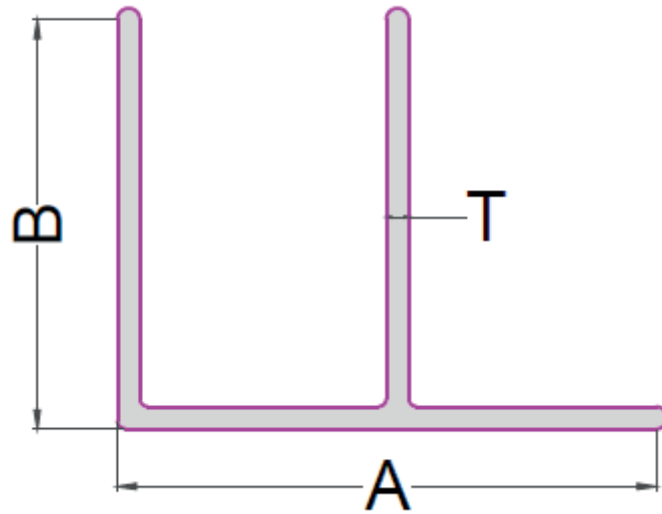

SL NO.	SECTION NO	A	B	T	WEIGHT RANGE KG/12'
1	1646	20.00	15.20	0.80	0.400-0.600

20 MM HANDLE 3

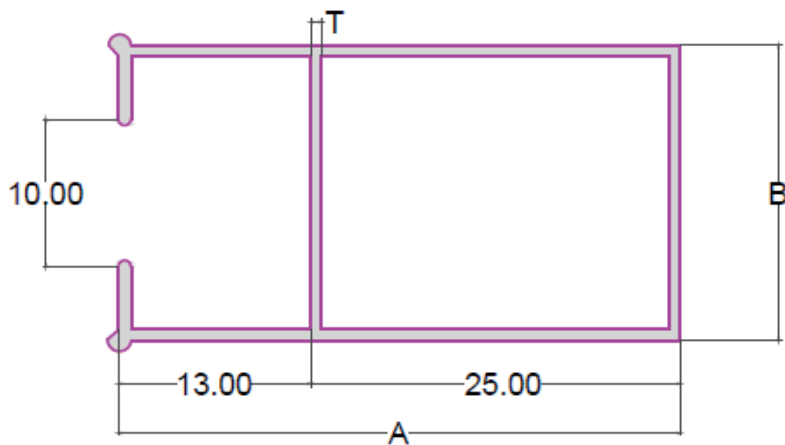

SL NO.	SECTION NO	A	B	T	WEIGHT RANGE KG/12'
1	1647	38.00	20.00	0.75	0.900-1.000

DIE NO 0901

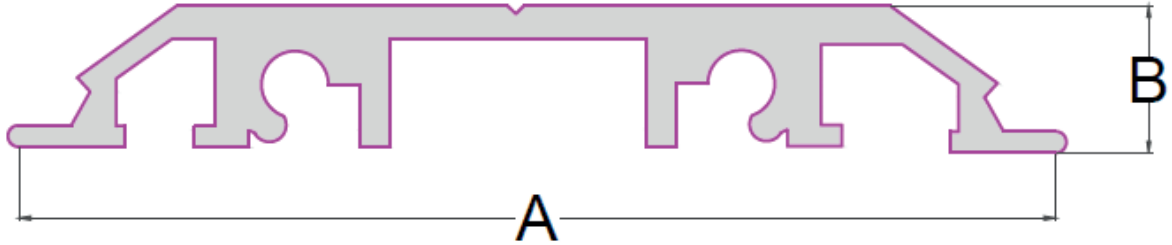

SL NO.	SECTION NO	A	B	WEIGHT RANGE KG/12'
1	1648	60.00	8.50	1.900-2.200

DIE NO 0932

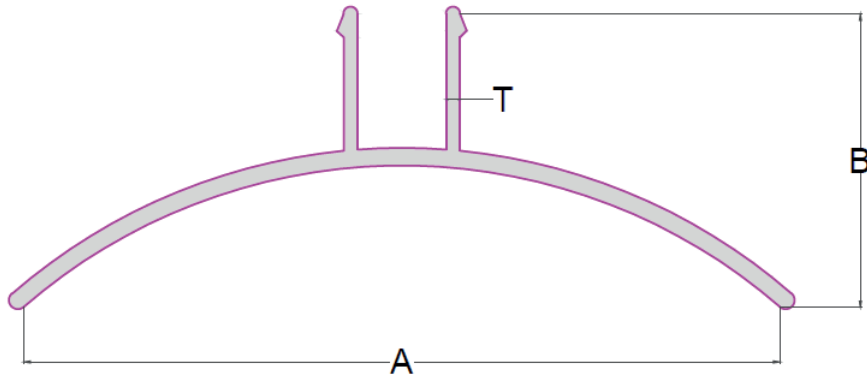

SL NO.	SECTION NO	A	B	T	WEIGHT RANGE KG/12'
1	1649	81.20	31.50	1.50	1.900-2.100

DIE NO 0927

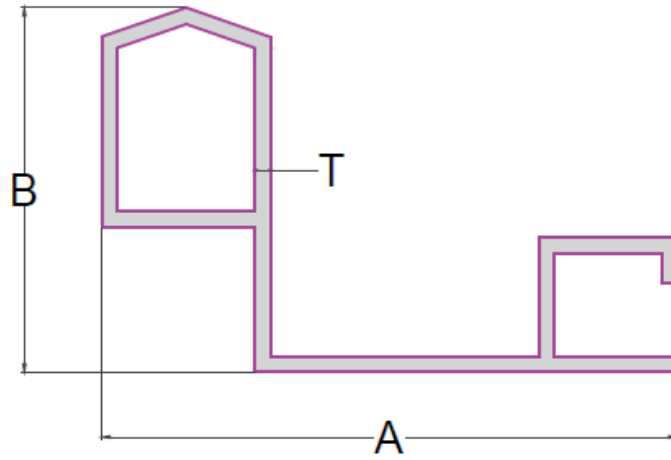

SL NO.	SECTION NO	A	B	T	WEIGHT RANGE KG/12'
1	1650	48.30	30.60	1.30	1.600-1.900

DIE NO 0925

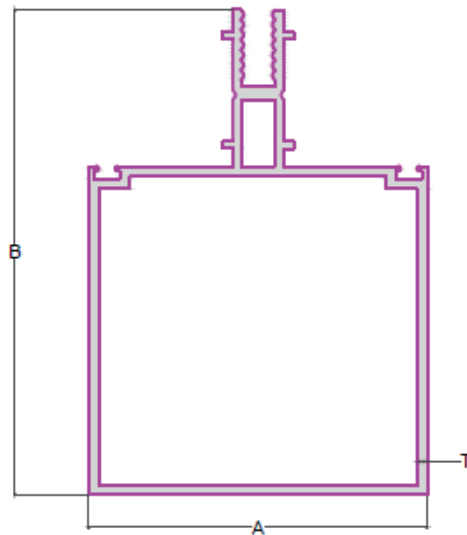

SL NO.	SECTION NO	A	B	T	WEIGHT RANGE KG/12'
1	1651	67.00	96.00	2.00	6.700-7.000

6 MM ROD

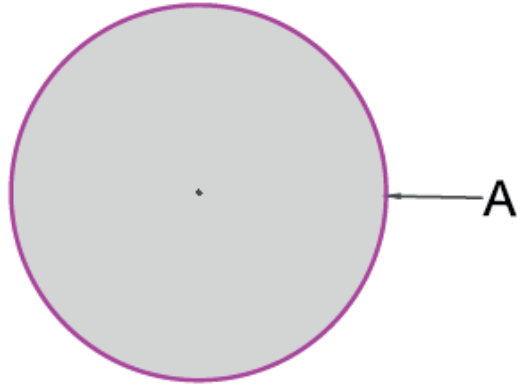

SL NO.	SECTION NO	A	WEIGHT RANGE KG/12'
1	1652	6.00	0.300-0.600

19 MM ROD

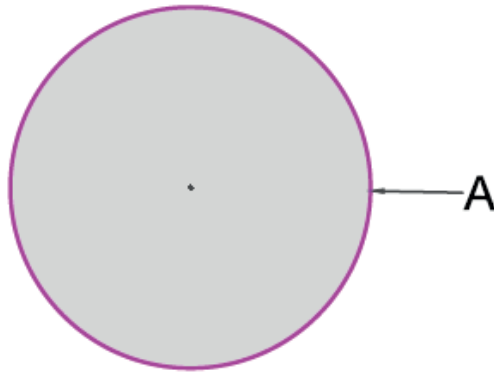

SL NO.	SECTION NO	A	WEIGHT RANGE KG/12'
1	1653	19.00	2.800-3.100

18 MM FR PIPE

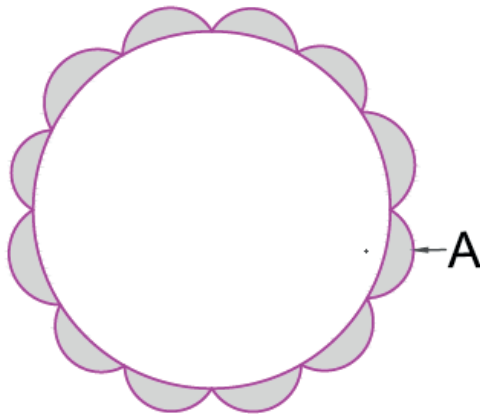

SL NO.	SECTION NO	A	WEIGHT RANGE KG/12'
1	1654	18.00	0.500-0.800

30 MM PR PIPE

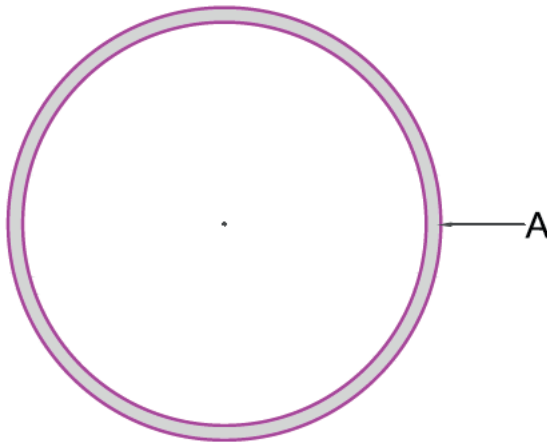

SL NO.	SECTION NO	A	WEIGHT RANGE KG/12'
1	1655	30.00	0.700-0.900

K-7152

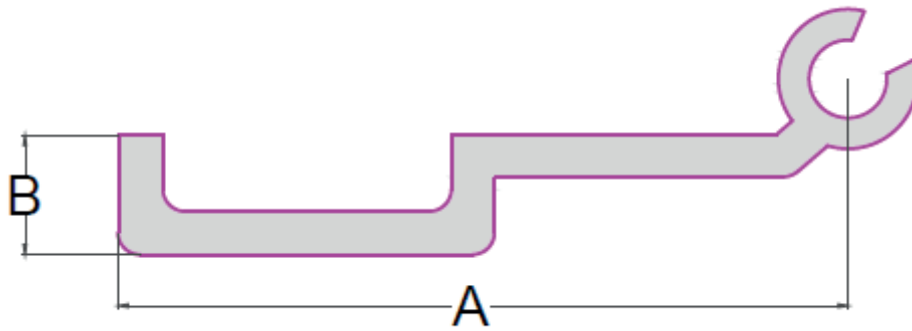

SL NO.	SECTION NO	A	B	WEIGHT RANGE KG/12'
1	1656	53.50	8.00	4.200-4.400

K-7151

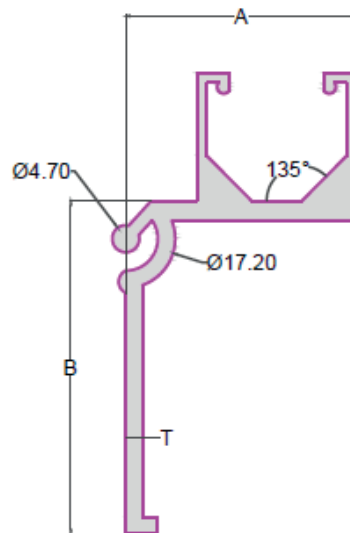

SL NO.	SECTION NO	A	B	T	WEIGHT RANGE KG/12'
1	1657	40.00	57.90	2.90	1.900-2.100